



PARTS CATALOG

SKID STEER COMPACT TRACK LOADER

440 440CT SERIES 3

APPLICABLE
ASN - N8M474469



BD07N496

TABLE OF CONTENTS

- General Information
- Section 2 – Engine
- Section 3 – Fuel System
- Section 4 – Electrical System
- Section 6 – Power train
- Section 7 – Brakes
- Section 8 – Hydraulics
- Section 9 – Chassis/Attachments
- Index

CNH America, LLC reserves the right to make improvements in design or changes in specifications at any time without incurring any obligation to install them on units previously sold.

All data given in this publication is subject to production variations. Dimensions and weights are only approximate. Illustrations do not necessarily show products in standard condition. For exact information about any particular product, please consult your Dealer

This unit first became available 01-2008			
REVISION HISTORY			
Issue	Issue Date	Applicable Machines	Remarks
First Edition	01Jan 08	440, 440CT Series 3 Skid Steer/Compact Track Loader	87632291 NA

TABLE OF CONTENTS

02-01	FAN, RADIATOR/OIL COOLER - COOLANT RECOVERY SYSTEM
02-02	RADIATOR/OIL COOLER
02-03	EXHAUST SYSTEM
02-04	EXHAUST SYSTEM, ASPIRATOR
02-05	AIR CLEANER - ENGINE
02-06	ENGINE - MOUNTING
02-07	ENGINE - MOUNTING (EUROPE)
02-08	ENGINE - BLOCK HEATER
02-09	CYLINDER BLOCK
02-10	CYLINDER BLOCK - COVERS, REAR GEAR
02-11	CYLINDER BLOCK - COVERS, FLYWHEEL
02-12	CYLINDER BLOCK - COVERS, FRONT
02-13	GEAR COVER - PLATE
02-14	CYLINDER HEAD COVERS
02-15	CYLINDER BLOCK STIFFENER PLATE
02-16	CYLINDER HEAD
02-17	OIL PUMP, PAN
02-18	ENGINE, OIL
02-19	OIL FILTER AND COOLER
02-20	OIL FILTERS - ENGINE
02-21	OIL PUMP - ENGINE
02-22	OIL FILL - ENGINE
02-23	REMOTE OIL DRAIN
02-24	MOTOR SENSORS - ENGINE OIL
02-25	BREATHER - ENGINE
02-26	MANIFOLD - INTAKE
02-27	MANIFOLD - EXHAUST
02-28	PISTONS - CONNECTING ROD
02-29	CONNECTING ROD
02-30	ROCKER SHAFT
02-31	FLYWHEEL - ENGINE
02-32	PULLEY - CRANKSHAFT
02-33	CAMSHAFT
02-34	CRANKSHAFT
02-35	COOLING SYSTEM - ENGINE
02-36	WATER PUMP
02-37	WATER PUMP - CONTROL
02-38	THERMOSTAT - ENGINE COOLING SYSTEM
02-39	FAN DRIVE
02-40	ENGINE - LIFT HOOK
02-41	TURBOCHARGER
03-01	FUEL LINES AND FUEL FILTER
03-02	CONTROLS - FOOT AND HAND THROTTLE
03-03	FUEL FILTER
03-04	FUEL INJECTION PUMP
03-05	FUEL PUMP
03-06	INJECTION PUMP - CONTROL
03-07	FUEL INJECTION SYSTEM - FUEL, SUPPLY
03-08	FUEL INJECTION SYSTEM - SUPPLY
03-09	FUEL INJECTION SYSTEM - DRAIN LINE
03-10	INJECTION EQUIPMENT - INJECTOR

TABLE OF CONTENTS

04-01	STARTER AND ALTERNATOR
04-02	ALTERNATOR MOUNTING
04-03	BATTERY - CABLES
04-04	HARNESS, ENGINE
04-05	CHASSIS, ELECTRICAL
04-06	ELECTRIC - CAB
04-07	CONSOLE - RH
04-08	CONSOLE - LH
04-09	CONTROL HANDLE, RH - BASIC
04-10	CONTROL HANDLE, LH - BASIC
04-11	CONTROL HANDLE, RH - DELUXE W/O AUX ELECTRIC
04-12	CONTROL HANDLE, LH - DELUXE W/O AUX ELECTRIC
04-13	CONTROL HANDLE, RH - DELUXE
04-14	CONTROL HANDLE, LH - DELUXE
04-15	DISCONNECT SWITCH - REMOTE JUMP START
04-16	WORK LIGHTS - LH
04-17	WORK LIGHTS - RH
04-18	ELECTRICAL - ROAD LIGHTS (NA)
04-19	ELECTRICAL - ROAD LIGHTS (EUROPE)
04-20	HEADLAMP - RH
04-21	HEADLAMP - LH
04-22	REAR LIGHT AND MOUNTING
04-23	BACKUP ALARM
04-24	ELECTRICAL ACCESSORY SOCKET
04-25	ELECTRICAL ACCESSORY SOCKET (EUROPE)
04-26	HORN - MOUNTING
04-27	ELECTRIC, FRONT AUXILIARY
04-28	ROTATING BEACON
04-29	SPECIAL PARTS FOR ITALY - LICENSE PLATE LIGHT
04-32	STROBE LIGHT
06-01	JOYSTICK CONTROL PLUMBING - H PATTERN
06-02	JOYSTICK CONTROL PLUMBING - ISO PATTERN (440)
06-03	JOYSTICK CONTROL PLUMBING - ISO PATTERN (440CT)
06-04	JOYSTICK VALVE KITS - H PATTERN, LH
06-05	JOYSTICK VALVE KITS - H PATTERN, RH
06-06	JOYSTICK VALVE KITS - ISO PATTERN, LH
06-07	JOYSTICK VALVE KITS - ISO PATTERN, RH
06-08	JOYSTICK VALVE KITS - ISO PATTERN, LH
06-09	HYDROSTATICS - PUMP, SUPPLY AND RETURN (440)
06-10	HYDROSTATICS - PUMP MOUNTING (440)
06-11	HYDROSTATICS - DRIVE MOTORS, CASE DRAIN (440)
06-12	HYDROSTATICS - PUMP, SUPPLY AND RETURN (440CT)
06-13	HYDROSTATICS - DRIVE MOTORS (440CT)
06-14	HYDROSTATICS - MULTI VALVE (440CT)
06-15	HYDROSTATICS - PUMP FITTINGS (440CT)
06-16	HYDROSTATICS - HOSES, PUMP AND DRIVE MOTORS
06-17	HYDROSTATICS - PUMP TO COOLER (440 WITH PILOT CONTROL)
06-18	HYDROSTATICS - MANIFOLD/CONTROL VALVE (440 WITH PILOT CONTROL)
06-19	HYDROSTATICS - PUMP FITTINGS (440 WITH PILOT CONTROL)
06-20	HYDROSTATICS - SINGLE SPEED, DRIVE MOTORS (440)
06-21	HYDROSTATICS - HOSES (440 WITH PILOT CONTROL)

TABLE OF CONTENTS

06-22	HYDROSTATICS - MULTI VALVE (440 WITH PILOT CONTROL)
06-23	HYDROSTATICS - TWO SPEED, DRIVE MOTORS (MECHANICAL CONTROL)
06-24	HYDROSTATICS - TWO SPEED, DRIVE MOTORS (PILOT CONTROL)
06-25	HYDROSTATICS - MULTI VALVE ASSEMBLY
06-26	HYDROSTATICS - TWO SPEED, VALVE ASSY
06-27	HYDROSTATICS - TWO SPEED, VALVE ASSY (440CT)
06-28	HYDROSTATICS - TWO SPEED, VALVE ASSY (WITH PILOT CONTROL)
06-29	HYDROSTATICS - RESONATOR (440CT EUROPE)
06-30	HYDROSTATICS - RESONATOR, WITH PILOT CONTROL (440 EUROPE)
06-31	HYDROSTATICS - RESONATOR, MECHANICAL CONTROL (440 EUROPE)
06-32	FILTER ASSY - MOUNTING
06-33	PUMP, TANDEM (440)
06-34	PUMP, TANDEM (440)
06-35	PUMP, TANDEM (440)
06-36	PUMP, TANDEM (440)
06-37	PUMP, TANDEM (440)
06-38	PUMP, TANDEM (440)
06-39	PUMP, TANDEM - REXROTH (87546976)
06-40	PUMP, TANDEM - PRESSURE RELIEF VALVE (87546976)
06-41	PUMP, TANDEM - PRESSURE RELIEF VALVE (87546976)
06-42	PUMP, TANDEM - INTERNAL GEAR PUMP (87546976)
06-43	PUMP, TANDEM - ROTARY GROUP, RIGHT HAND ROTATION (87546976)
06-44	PUMP, TANDEM - ROTARY GROUP, LEFT HAND ROTATION (87546976)
06-45	PUMP, TANDEM - CONTROL, HYDRAULIC (87546976)
06-46	PUMP, TANDEM - CONTROL CARTRIDGE WITH ORIFICE (87546976)
06-47	PUMP, TANDEM - REXROTH (87546977)
06-48	PUMP, TANDEM - PRESSURE RELIEF VALVE (87546977)
06-49	PUMP, TANDEM - INTERNAL GEAR PUMP (87546977)
06-50	PUMP, TANDEM - ROTARY GROUP, RIGHT HAND ROTATION (87546977)
06-51	PUMP, TANDEM - ROTARY GROUP, LEFT HAND ROTATION (87546977)
06-52	PUMP, TANDEM - CONTROL, HYDRAULIC (87546977)
06-53	PUMP, TANDEM - CONTROL CARTRIDGE WITH ORIFICE (87546977)
06-54	PUMP, GEAR (WITHOUT HIGH FLOW)
06-55	PUMP, GEAR (HIGH FLOW)
06-56	MOTOR ASSY - SINGLE SPEED
06-57	MOTOR ASSY - SINGLE SPEED
06-58	MOTOR ASSY - SINGLE SPEED
06-59	MOTOR ASSY - TWO SPEED
06-60	MOTOR ASSY - TWO SPEED
06-61	MOTOR ASSY - TWO SPEED
06-62	MOTOR ASSY - HYDROSTATIC DRIVE (440CT)
06-63	DRIVE LINE
06-64	AXLE ASSY
06-65	WHEELS - SOLID FLEX
06-66	WHEELS
06-67	TRACK (440CT)
06-68	FINAL DRIVE (440CT)
07-01	BRAKE SYSTEM - HYDRAULIC
08-01	HYDRAULICS - TILT
08-02	HYDRAULICS - LIFT
08-03	HYDRAULICS - CASE DRAIN

TABLE OF CONTENTS

08-04	HYDRAULICS - RIDE CONTROL
08-05	HYDRAULICS - SELF LEVELING
08-06	HYDRAULICS - SECONDARY FRONT AUXILIARY
08-07	HYDRAULICS - ATTACHMENT, IMPLEMENT (PILOT CONTROL)
08-08	HYDRAULICS - ATTACHMENT, PROPORTIONAL (PILOT CONTROL)
08-09	HYDRAULICS - ATTACHMENT (MECHANICAL CONTROL)
08-10	HYDRAULICS - COUPLER SYSTEM
08-11	HYDRAULICS - COUPLER SYSTEM
08-12	HYDRAULICS - COUPLER SYSTEM (ITALIAN)
08-13	HYDRAULICS - COUPLER SYSTEM (ITALIAN)
08-14	CYLINDER - TILT
08-15	CYLINDER - LIFT
08-16	HIGH FLOW - SUPPLY AND RETURN
08-17	HIGH FLOW - AUXILIARY SYSTEM
08-18	HIGH FLOW - CONTROL VALVE
08-19	CONTROL VALVE ASSEMBLY - HIGH FLOW
08-20	CONTROL VALVE - 87583286 VALVE ASSY
08-21	CONTROL VALVE - 87583285 VALVE ASSY
08-22	CONTROL VALVE - 87546974 VALVE ASSY
08-23	CONTROL VALVE - 87546975 VALVE ASSY
08-24	CONTROL VALVE - SEAL REPLACEMENT KITS
08-25	CONTROL VALVE - MAIN RELIEF VALVE
08-26	CONTROL VALVE - RELIEF VALVES
08-27	CONTROL VALVE - SPOOL END GROUP
08-28	CONTROL VALVE - SPOOL END GROUP
08-29	CONTROL VALVE - SPOOL END GROUP
08-30	CONTROL VALVE - CHECK VALVE GROUP
08-31	CONTROL VALVE - SPOOL END GROUP, DETENT
08-32	CONTROL VALVE - SPOOL END GROUP
08-33	CONTROL VALVE - SPOOL END GROUP
08-34	CONTROL VALVE - SEAL REPLACEMENT KITS
08-35	CONTROL VALVE - SPOOL END GROUP
08-36	CONTROL VALVE - SPOOL END GROUP
08-37	CONTROL VALVE - SPOOL END GROUP
08-38	CONTROL VALVE - SPOOL END GROUP, EHPV
08-39	CONTROL VALVE - SPOOL END GROUP, EHPV
08-40	SECONDARY FRONT AUXILIARY - VALVE ASSY
09-01	LOADER LIFT
09-02	LIFT CYLINDER - COVERS
09-03	COUPLER, MECHANICAL
09-04	COUPLER, MECHANICAL (ITALIAN)
09-05	COUPLER, HYDRAULIC
09-06	BUCKETS - LOADER, DIRT / FOUNDRY
09-07	BUCKETS - LOADER (LOW PROFILE/ EXTENDED LOW PROFILE)
09-08	BUCKETS - LOADER (UTILITY/LIGHT MATERIAL)
09-09	BUCKETS - LOADER (HEAVY DUTY)
09-10	BUCKET, CUTTING EDGE (BOLT-ON CUTTING EDGE)
09-11	SPECIAL PARTS FOR ITALY - GUARD, BUCKET
09-12	PALLET FORK
09-13	CONTROLLER - MOUNTING (PILOT CONTROL)
09-14	CONSOLE - RH

TABLE OF CONTENTS

09-15	CONSOLE - LH
09-16	CHASSIS (440)
09-17	CHASSIS (440)
09-18	CHASSIS (440CT)
09-19	CHASSIS (440CT)
09-20	LOADER & GROUND DRIVE CONTROL - RH
09-21	LOADER & GROUND DRIVE CONTROL - LH
09-22	LOADER & GROUND DRIVE CONTROL - LINKAGE
09-23	CONTROLS - AUXILIARY HYDRAULICS
09-24	HOOD
09-25	HOOD - AIR CONDITIONING
09-26	REAR DOOR
09-27	REAR DOOR - LOUVERED (EUROPE)
09-28	LOCK - REAR DOOR
09-29	CAB DOOR - MOUNTING
09-30	CAB DOOR - WASHER SYSTEM
09-31	CAB DOOR
09-32	CAB DOOR - VISOR
09-33	CAB DOOR - WIPER MOUNTING
09-34	CAB DOOR - HANDLE
09-35	DEMOLITION DOOR - MOUNTING
09-36	DEMOLITION DOOR
09-37	FLOOR MAT
09-38	CAB - FRAME AND SEAT BAR
09-39	SEAT BAR
09-40	SEAT BELT, LAP BELT (2 IN)
09-41	SEAT BELT, LAP BELT (3 IN)
09-42	SHOULDER BELT
09-43	REAR VIEW MIRROR
09-44	SPECIAL PARTS FOR ITALY - MIRROR, REAR VIEW
09-45	SEAT MOUNTING - STANDARD SEAT
09-46	SEAT MOUNTING - SUSPENSION SEAT
09-47	SEAT MOUNTING - DELUXE SUSPENSION SEAT
09-48	REAR WINDOW
09-49	REAR WINDOW - HEAT AND AIR CONDITIONING
09-50	TOP WINDOW
09-51	SIDE WINDOWS
09-52	HEADLINER - STANDARD
09-53	HEADLINER - HEATER AND AIR CONDITIONING
09-54	INTERIOR TRIM
09-55	RADIO - SPEAKERS AND ANTENNA
09-56	RADIO - SPEAKERS AND HOUSING
09-57	HEATER SYSTEM
09-58	HEATER SYSTEM
09-59	AIR CONDITIONING SYSTEM
09-60	HEATER ASSEMBLY
09-61	HEATER AND AIR CONDITIONING ASSEMBLY
09-62	HEAT SHIELD
09-63	SOUNDPROOFING - SEAL
09-64	NOISE CONTROL - REAR DOOR (EUROPE)
09-65	LIFT HOOK - SINGLE POINT

TABLE OF CONTENTS

09-66	LIFT HOOK
09-67	DECALS - ENGLISH
09-68	DECAL (440CT)
09-69	DECALS
09-70	DECALS
09-71	DECALS - DANISH, DUTCH, FINNISH
09-72	DECALS - FRENCH, GERMAN, GREEK
09-73	DECALS - ITALIAN, NORWEGIAN, POLISH
09-74	DECALS - PORTGUESE, SPANISH, SWEDISH
09-75	DECALS - BRAZILIAN PORTUGUESE, CANADIAN FRENCH, LATIN AMERICAN SPANISH

GENERAL INFORMATION

PROPRIETARY NOTICE

The contents of this manual are proprietary data of this company. Reproduction or use of any part for other than the operation and maintenance of our equipment is permissible only if expressly authorized in writing.

Additional copies may be obtained from your dealer. Address requests for copies to your Dealer and refer to the publication part number appearing on the bottom of the rear catalog cover or on the title page.

COMPANY POLICY

Company policy, which is one of continuous improvement, reserves the right to change prices and to make changes in design and specification at any time without notice and without obligation to modify units previously built.

All data given in this book is subject to production variations. Dimensions and weights are approximate only and the illustrations do not necessarily show machines in standard condition. For exact information about any particular machine please consult your dealer.

PARTS AND ACCESSORIES

Genuine parts and accessories have been specifically designed for these machines.

We would like to point out that “non-genuine” parts and accessories have NOT been examined and released by the Company. The installation and or use of such products could have negative effects upon the design characteristics of your machine and thereby affect its safety. The company is not liable for any damage caused by the use of “non-genuine” parts and accessories.

IMPROVEMENTS

We are continually striving to improve our products. We reserve the right to make improvements or changes when it becomes practical and possible to do so, without incurring any obligation to make changes or additions to the equipment sold previously.

MODEL CODES

The range of machines listed may not be available in all countries or markets therefore, for the latest information consult your local dealer.

OWNER ASSISTANCE

We want you to be completely satisfied with your investment. Normally any problems with your equipment will be handled by your dealer's Service Department; however, misunderstandings can occur. If your problem has not been handled to your satisfaction, we suggest the following:

1. Contact the owner or General Manager of the dealership, explain the problem, and request assistance. When additional assistance is needed, your dealer has direct access to our office.
2. Provide your dealer with:
 - Your Name, Address, and Telephone number
 - Machine Model and Serial Number
 - Dealership Name and Address
 - Machine purchase date and amount of use
 - Nature of problem

Be aware that your problem will likely be resolved in the dealership using the dealer's facilities, equipment, and personnel. So it is important that your initial contact be with the dealer.

SPARE PARTS

To maintain operating efficiency, use original spare parts.

When ordering parts, give the following information:

- Machine Model
- Machine and Engine Serial Numbers
- Part Number from the Parts Catalog

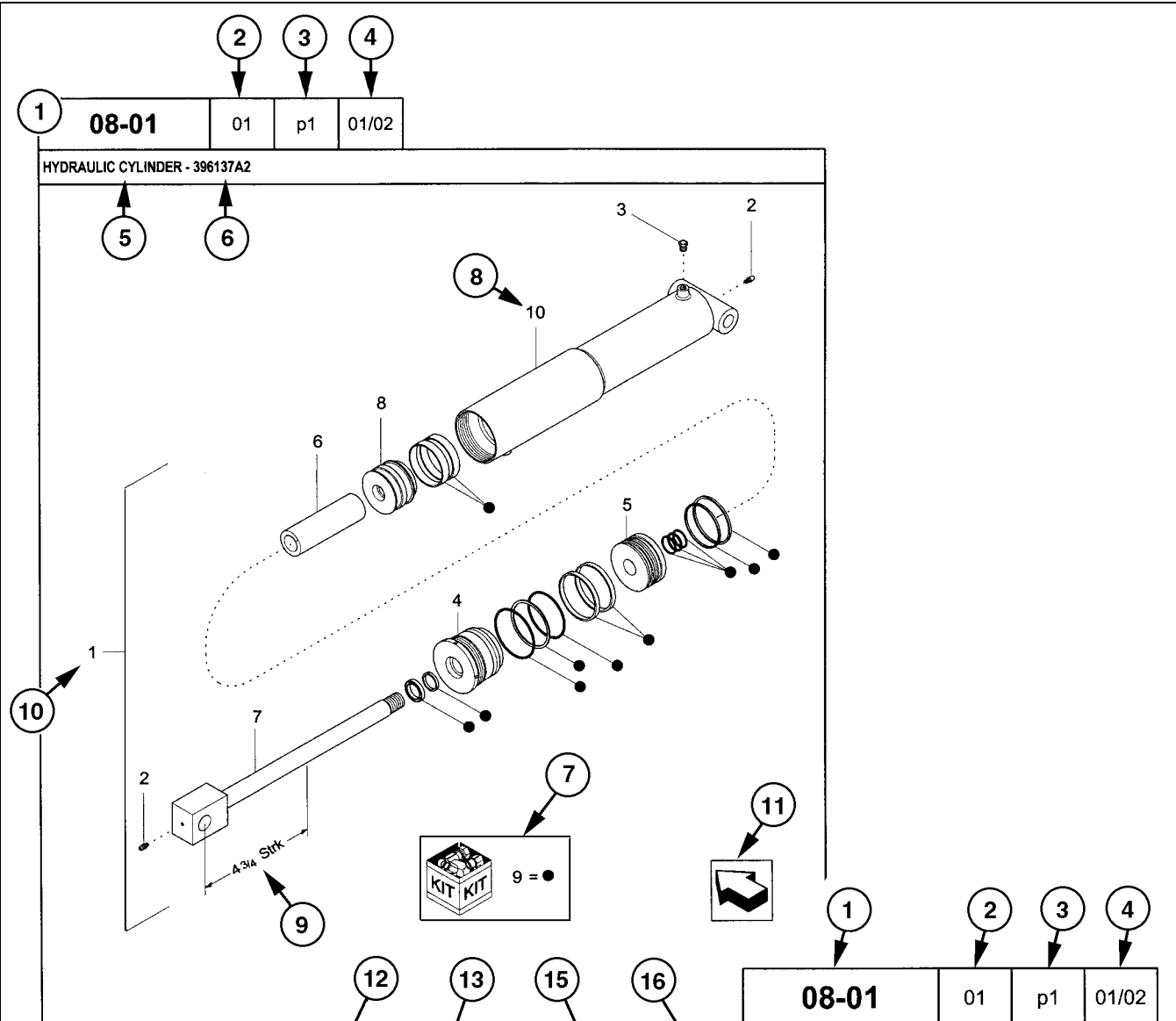

REF	FN	PART NUMBER	YR/SN	QTY	DESCRIPTION
1	1	396137A2	BTW 01/85 & 02/02	1	CYLINDER ASSY. 4-3/4 in strk, Inc 2-10
2		31-95	Before 01/85	2	FITTING
2		219-8	From 01/85	2	NIPPLE, LUBE Grease, 1/4 tpr x 17/32
3		{402475A2}		1	BREATHER
4		402474A1		1	CAP CYLINDER END
5		402468A1	BSN JJC0189199	1	PISTON ROD/GLAND
5		145221C3	ASN JJC0189200	1	PISTON
6		402471A1		1	SPACER
7		402473A1		1	ROD, PISTON
8		402469A1		1	PISTON ROD/GLAND
9		402476A1		1	PACKAGE, SEALS
10		NSS		1	NOT SERVICED SEPARAT CASE ASSEMBLY
(1)	08-20				
		STANDARD			
		MODELS			

HOW TO USE YOUR PARTS CATALOG

1. Figure Number
2. Sequence Code within the Figure Number
3. Page Number within the Sequence Code
4. Date of Printing (month / year)
5. Figure Description
6. General information regarding the figure
7. Parts supplied in repair kits per symbol reference
8. Figure call-out of the part number (REF)
9. Technical specifications relating to the part indicated
10. Figure call-out includes bracketed items, the included items may also be listed in the additional description area
11. Orientation - Arrow indicates front of the machine
12. Footnote - Additional information relating to the part number. In this example, 08-20 equals another figure that this part is shown on
13. Part Number
 - NSS = Not Serviced Separately (Non-serviced parts)
 - Bracketed numbers = not available as service parts in this market
14. Not Available as service part in this market
15. YR/SN
 - Year
 - Before 01/85 = Part valid for production January 1985 and before
 - From 01/85 = Part valid for production from January 1985 and after
 - BTW 01/85 & 02/02 = Part valid for machines produced between January 1985 and February 2002.
 - Serial Number (P.I.N.)
 - BSN JJC0268800 = Part valid for serial number JJC0268800 and below
 - ASN JJC0268800 = Part valid for serial number JJC0268800 and above
 - BTW JJC0178000 & JJC0179000 = Part valid for serial numbers between JJC0178000 & JJC0179000
16. Total Quantity of the Part referred to in the page. The quantity can be replaced by the following indications:
 - AR = As Required
 - X = As required
17. Part Description
18. Additional description of the part to help confirm identification
19. Figure Notes
20. Model Number(s)

RIGHT-HAND AND LEFT-HAND

The reference to right-hand and left-hand in this catalog is identified by the operator standing at the rear of the basic unit (without rear attachment), looking toward the front of the machine (in normal forward travel).

For pages covering any machine attachments, right-hand and left-hand are defined by the operator sitting in the position for proper operation of the attachment.

DIMENSIONS

Metric and U.S. hardware dimensions do not show the numeric designations of standard coarse threads. A number following a semi colon (;) is the class or grade of hardware. A comma (,) represents the decimal point (.) used in U.S. dimensions.

EXPLANATION OF ABBREVIATIONS

AC	Alternating Current
adj	adjustable
amp	ampere
AR	As required
ASN	Serial number and after P.I.N. and after
blkhd	bulkhead
br	branch
BSN	before Serial number before P.I.N.
BTW	between
cc	cubic centimetre
cl	class
cmprsn	compression
cn pt	cone point
cp pt	cup point
CRS	Chrome Alloy Steel
CST	Carbon Steel
cu yd	cubic yard
DC	Direct Current
deg	degree
dg pt	dog point
dia	diameter
dr type	drive type
fc	face
fc sl	face seal
fem	female
fem PT	female pipe thread
fl	flare
flat pt	flat point
ft	feet or foot
ga	gauge
gal	gallon or gallons
gpm	gallons per minute
gr	grade
hd	head
hdg pt	half dog point
hp	horsepower
ID	inside diameter
in	inch or inches
Incl.	Includes
inv fl	inverted flare
K	kilo
kg	kilogram
km/h	kilometers per hour

L	litre
lb	pounds
lb-ft	pound-foot
lg	long
LH	left-hand
LH thd	left-hand thread
M	(prefix) metric thread size
m	metre
ml	milliliter
mm	millimetre
NF	National Fine
No.	number
NPT	National Pipe Thread
NS	National Super Fine
OD	outside diameter
ohm	electrical unit of resistance
Or	O-ring
ORB	O-ring boss
ORFS	O-ring face seal
ov cntr	over center
ov pt	oval point
oz	ounce
P	pitch
psi	pounds per square inch
pt	pint
PT	pipe thread
rd	round
rd holes	round holes
RH	right-hand
RH thd	right-hand thread
rpm	revolutions per minute
sl	self-locking
sq	square
SST	Stainless Steel
st	self-tapping
strk	stroke
sw	swivel
T	teeth
thk	thick
tpr	taper
tube OD	tube outside diameter
V	volt or volts
W	watt or watts
X	as required
yd	yard

SECTION INDEX

Engine

02-01	FAN, RADIATOR/OIL COOLER - COOLANT RECOVERY SYSTEM
02-02	RADIATOR/OIL COOLER
02-03	EXHAUST SYSTEM
02-04	EXHAUST SYSTEM, ASPIRATOR
02-05	AIR CLEANER - ENGINE
02-06	ENGINE - MOUNTING
02-07	ENGINE - MOUNTING (EUROPE)
02-08	ENGINE - BLOCK HEATER
02-09	CYLINDER BLOCK
02-10	CYLINDER BLOCK - COVERS, REAR GEAR
02-11	CYLINDER BLOCK - COVERS, FLYWHEEL
02-12	CYLINDER BLOCK - COVERS, FRONT
02-13	GEAR COVER - PLATE
02-14	CYLINDER HEAD COVERS
02-15	CYLINDER BLOCK STIFFENER PLATE
02-16	CYLINDER HEAD
02-17	OIL PUMP, PAN
02-18	ENGINE, OIL
02-19	OIL FILTER AND COOLER
02-20	OIL FILTERS - ENGINE
02-21	OIL PUMP - ENGINE
02-22	OIL FILL - ENGINE
02-23	REMOTE OIL DRAIN
02-24	MOTOR SENSORS - ENGINE OIL
02-25	BREATHER - ENGINE
02-26	MANIFOLD - INTAKE
02-27	MANIFOLD - EXHAUST
02-28	PISTONS - CONNECTING ROD
02-29	CONNECTING ROD
02-30	ROCKER SHAFT
02-31	FLYWHEEL - ENGINE
02-32	PULLEY - CRANKSHAFT
02-33	CAMSHAFT
02-34	CRANKSHAFT
02-35	COOLING SYSTEM - ENGINE
02-36	WATER PUMP
02-37	WATER PUMP - CONTROL
02-38	THERMOSTAT - ENGINE COOLING SYSTEM
02-39	FAN DRIVE
02-40	ENGINE - LIFT HOOK
02-41	TURBOCHARGER

FAN, RADIATOR/OIL COOLER - COOLANT RECOVERY SYSTEM

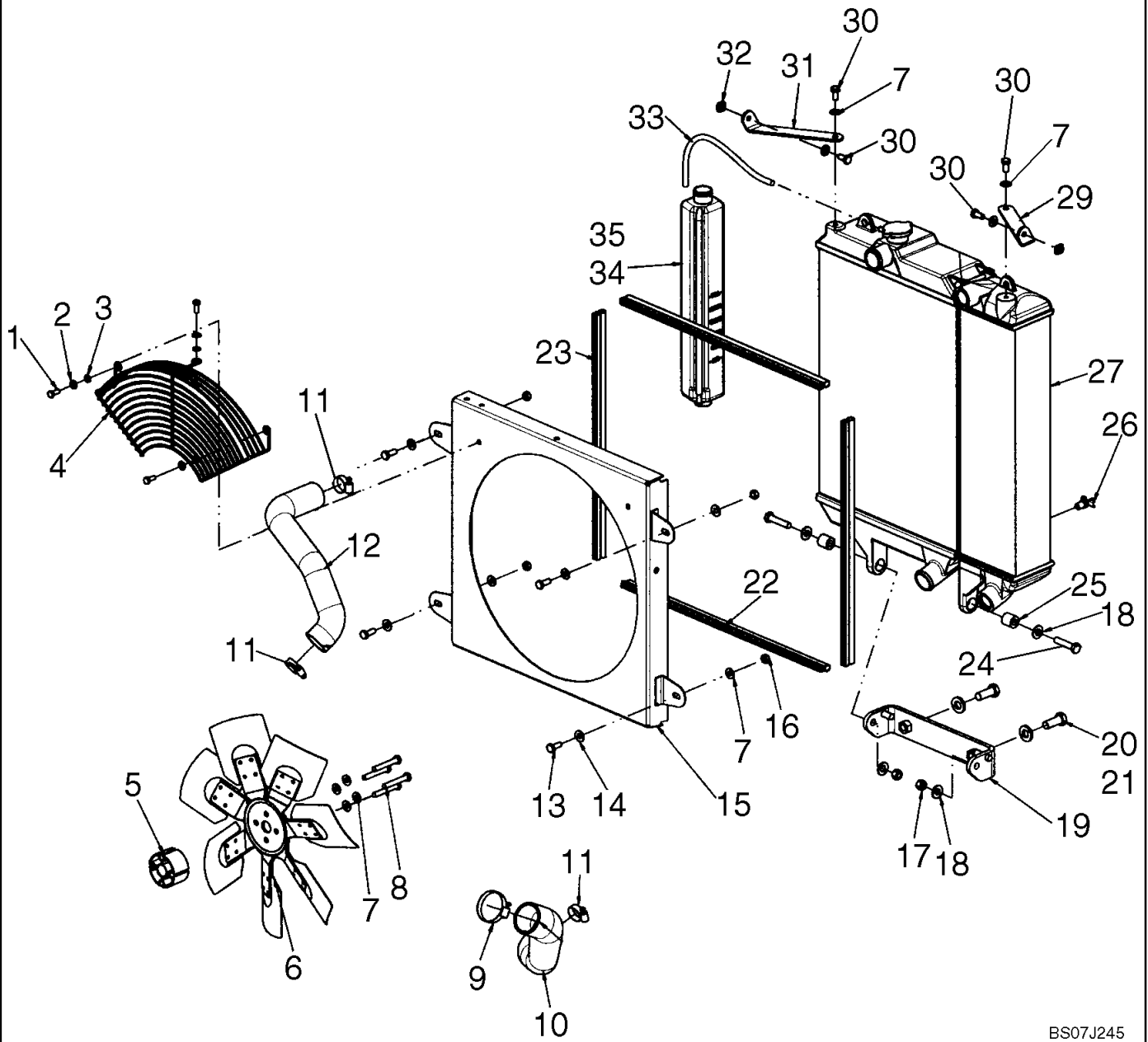

FAN, RADIATOR/OIL COOLER - COOLANT RECOVERY SYSTEM

REF	FN	PART NUMBER	YR/SN	QTY	DESCRIPTION
1		120104		3	BOLT, Hex, M8 x 20, 8.8
2		322358		3	WASHER, SPRING, Belleville, M8
3		86624184		3	WASHER, M8 x 16 x 1.6
4		{87594970}		1	Fan Guard
5		87565745		1	SPACER, Fan Spacer, 43mm
5		87565746		1	SPACER, Fan Spacer, 60mm (Europe)
6		87025470		1	FAN, 480 Dia Pusher
7		140045		12	WASHER, SPRING, Belleville, M10
8		120071		4	BOLT, Hex, M10 x 65, 8.8
8		120073		4	BOLT, Hex, M10 x 80, 8.8, Used With 87565746 Fan Spacer
9		86625032		1	CLAMP, HOSE, #48, 2.56/3.50 Type F Worm
10		87661380		1	HOSE, Formed Hose, Lower Radiator
11		84674		3	CLAMP, HOSE, #28, 1.31/2.25 Type F Worm
12		87661378		1	HOSE, Formed Hose, Upper Radiator
13		43139		4	SCREW, M10 X 25 Full 8.8 ZND
14		86625253		4	WASHER, M11 x 24 x 2
15		87660828		1	SHROUD, Fan Shroud
16		86500689		4	NUT, M10, CI 10
17		{87533547}		2	Nut, M12 x 1.75 10 ZND
18		86625254		4	WASHER, M12 x 28 x 2.5
19		87676100		1	BRACKET, Bracket, Lower Hinge Mount
20		43168		2	BOLT, Hex, M16 x 40, 8.8
21		86639326		2	WASHER, M17.5 x 34 x 5, HT
22		{87578980}		2	Bulb Seal, 590mm (23 1/4 in.)
23		{87648128}		2	Bulb Seal, 562mm (22 1/8 in.)
24		87021825		2	BOLT, Hex, M12 x 55, 10.9
25		87626729		2	SPACER
26		86625234		1	COCK, DRAIN
27		87660842		1	RADIATOR, Radiator And Oil Cooler; See Fig 02-02
28		87687375		1	RADIATOR, Radiator Cap
29		87651800		1	BRACKET, Upper Radiator Mount, LH
30		43138		4	SCREW, Hex, M10 x 20, 8.8, Full Thd
31		87651799		1	BRACKET, Upper Radiator Mount, RH
32		230427A1		2	NUT

440CT 440

FAN, RADIATOR/OIL COOLER - COOLANT RECOVERY SYSTEM

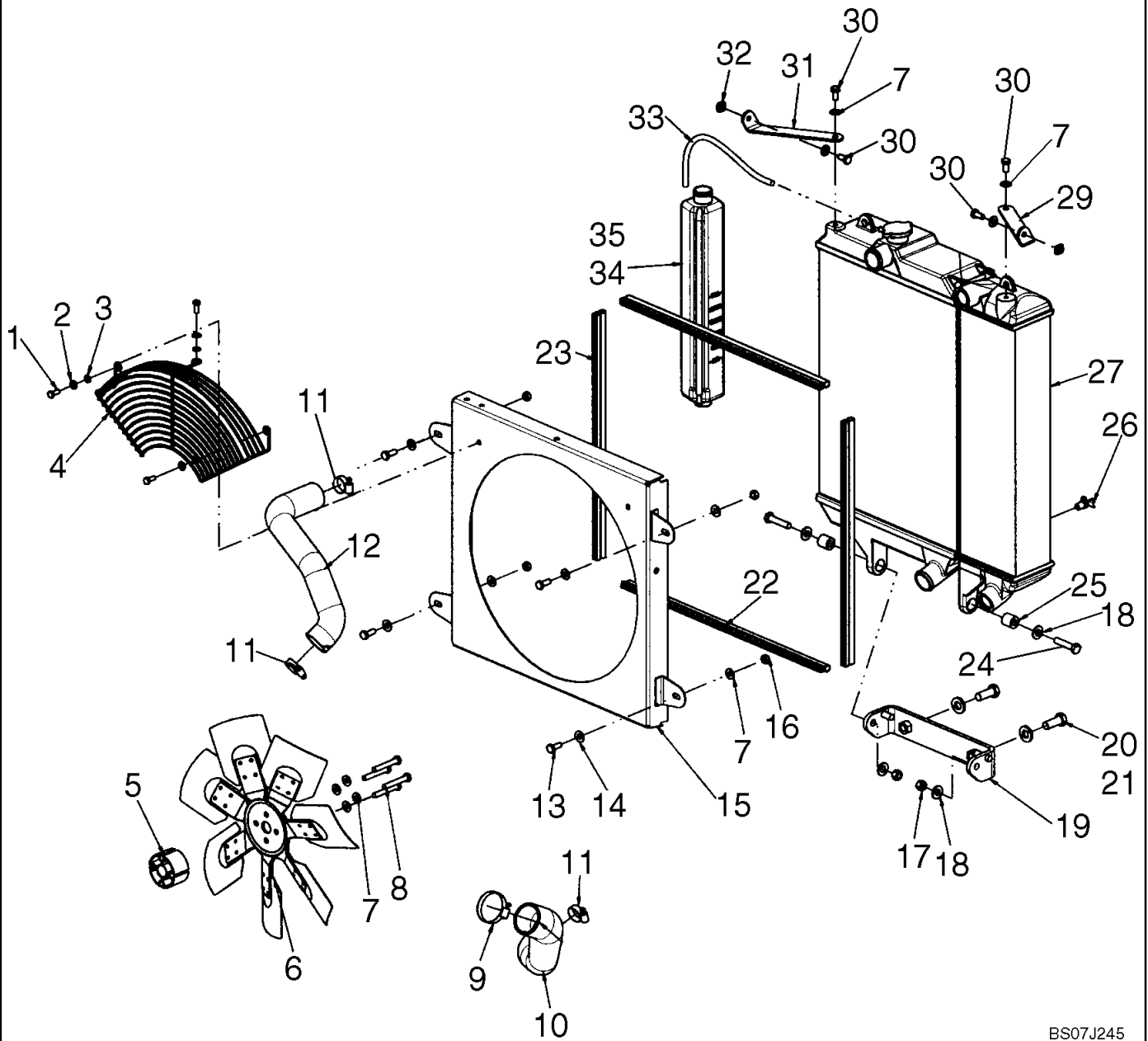

FAN, RADIATOR/OIL COOLER - COOLANT RECOVERY SYSTEM

REF	FN	PART NUMBER	YR/SN	QTY	DESCRIPTION
33		{87534725}		1	Coolant Recovery Hose, 400mm (15 3/4 in.)
34		87020980		1	RESERVOIR, COOLANT EXPNSN, Coolant Recovery Bottle; Incl. 35
35		257884A1		1	PLUG, Cap

	440CT 440
--	------------------

RADIATOR/OIL COOLER

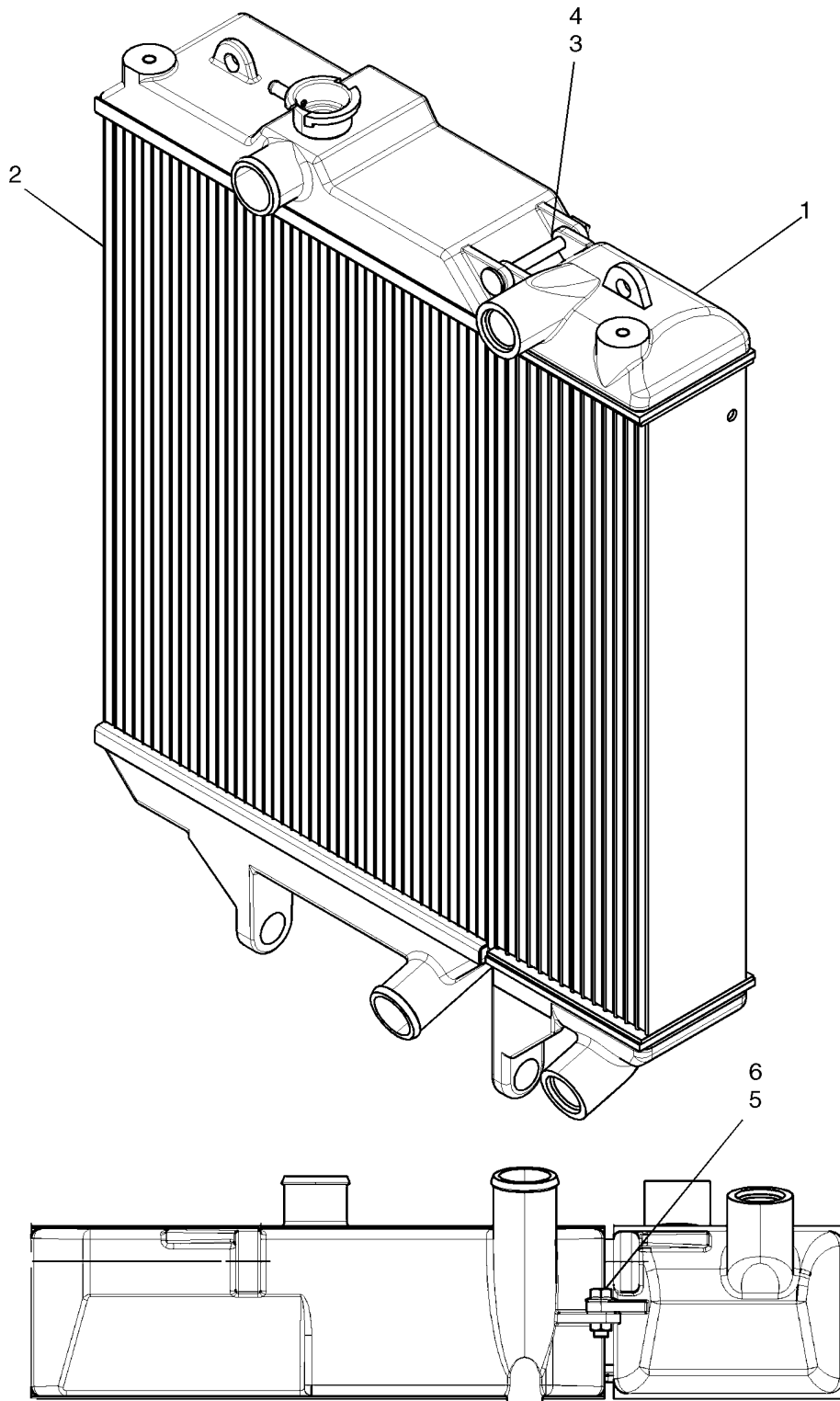

RADIATOR/OIL COOLER

REF	FN	PART NUMBER	YR/SN	QTY	DESCRIPTION
		87660842		1	RADIATOR, Incl 1 - 8
1		87687372		1	RADIATOR, Oil Cooler
1		87688650		1	COOLER, OIL, Low Fin Density Oil Cooler
2		87688523		1	RADIATOR, Standard Radiator And Decal
2		87688649		1	RADIATOR, Low Fin Density Radiator And Decal
3		87687373		1	RADIATOR, Pin
4		87687374		1	RADIATOR, Clip
5		9804262		1	BOLT, Hex Flg, M10 x 30, 8.8
6		9804278		1	NUT, M10 x 1.5, Flg, Cl 8
7		87687376		1	RADIATOR, Seal
8		87687375		1	RADIATOR, Radiator Cap; Not Illustrated

440CT 440

EXHAUST SYSTEM

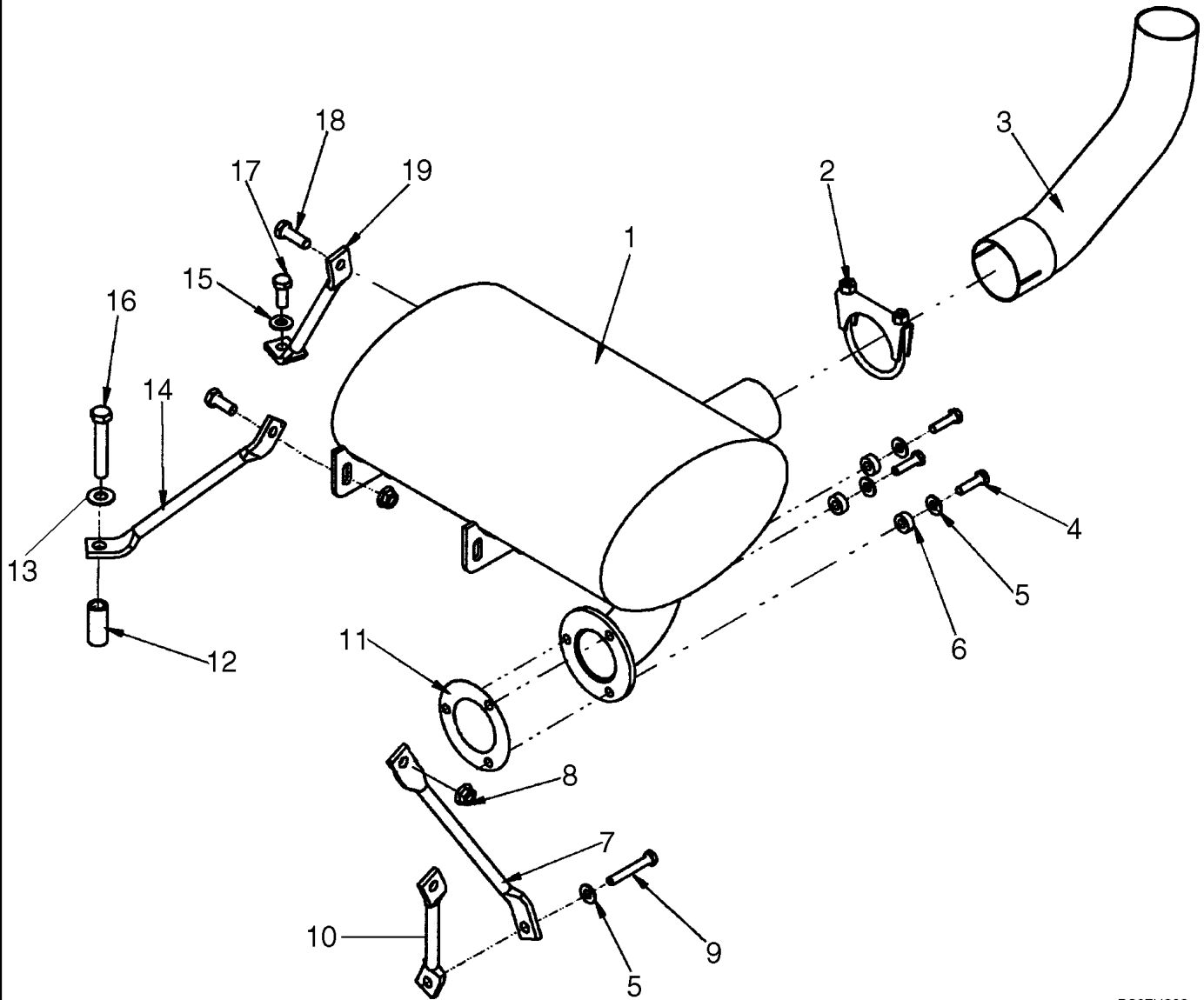

EXHAUST SYSTEM

REF	FN	PART NUMBER	YR/SN	QTY	DESCRIPTION
1		{87572831}		1	Muffler, Insulated
2		87461995		1	CLAMP
3		87654919		1	PIPE, EXHAUST SYSTEM, Tube, Exhaust
4		43138		3	SCREW, Hex, M10 x 20, 8.8, Full Thd
5		86625263		4	WASHER, M8 x 20 x 1.6
6		86633393		3	SPACER, 11/32 ID X 3/4 OD X 5/16 Thk; If Used
7		87033361		1	ROD, Muffler Support
8		411345A1		3	NUT, M10
9		16044321		1	BOLT, Hex, M8 x 55, 8.8
10		87029961		1	ROD, Muffler Support
11		86606073		1	GASKET, Muffler
12		86608204		1	SPACER
13		140046		1	WASHER, SPRING, Belleville, M12
14		87034631		1	ROD, Muffler Support
15		140045		1	WASHER, SPRING, Belleville, M10
16		9706717		1	BOLT, Hex, M12 x 70, 8.8, Full Thd
17		43139		3	SCREW
18		87034630		1	ROD, Muffler Support
19		43140		1	BOLT, Hex, M10 x 30, 8.8, Full Thd
20		87584781		1	MUFFLER, Muffler Wrap, Europe; Not Illustrated
21		87393399		9	SPRING, Stainless Steel Tie; Not Illustrated

440 440CT

EXHAUST SYSTEM, ASPIRATOR

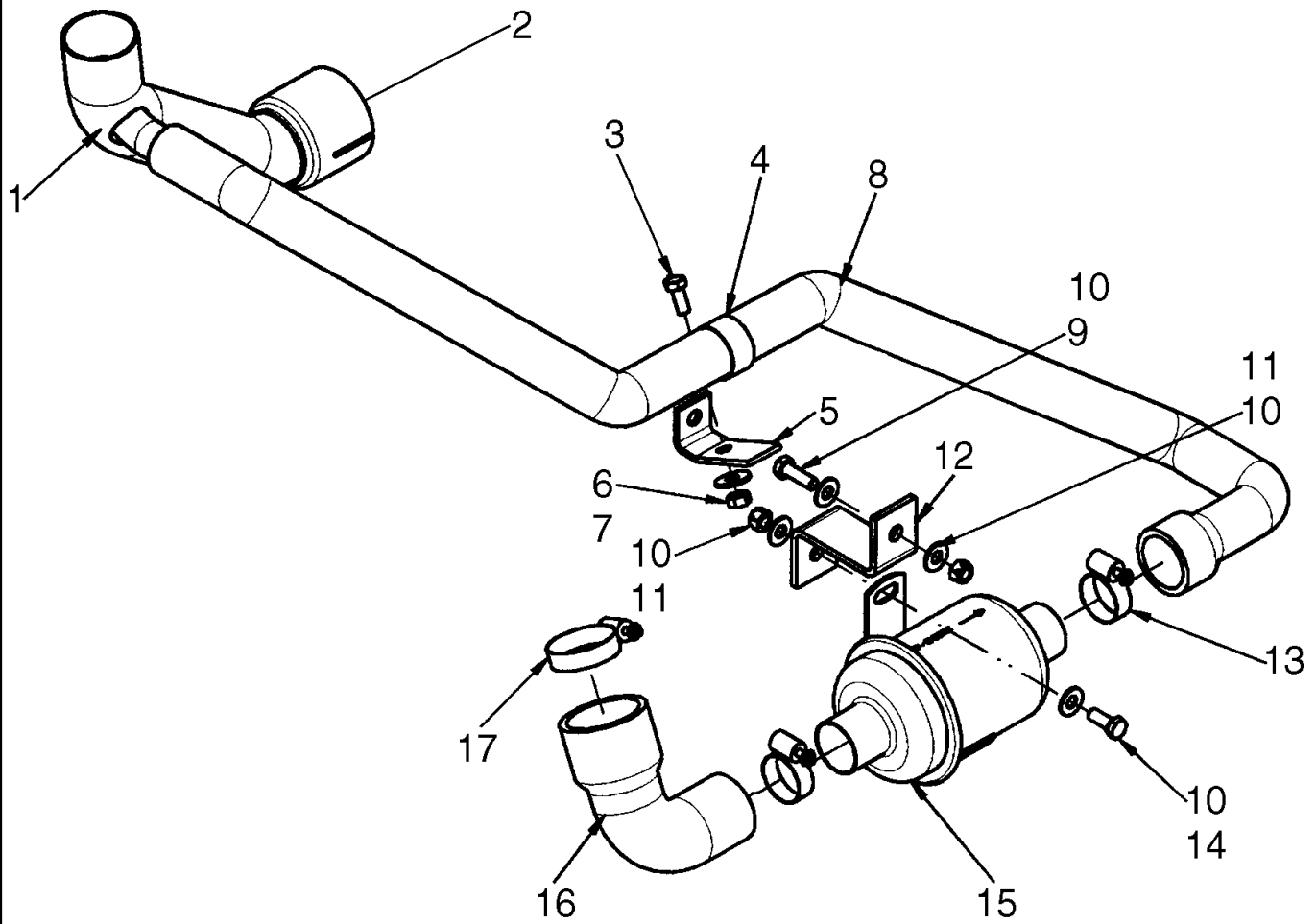

EXHAUST SYSTEM, ASPIRATOR

REF	FN	PART NUMBER	YR/SN	QTY	DESCRIPTION
		87638327		1	KIT, SERVICE, Kit, Aspirator; Incl 1 - 17
1		507586		1	CLAMP, HOSE, #20, 0.81/1.75 Type F Worm
2		87654923		1	PIPE, EXHAUST SYSTEM, Aspirator
3		86625000		1	BOLT, Hex, M8 x 18, 8.8, Full Thd
4		{87648719}		1	CLAMP 36.5 mm P Insul 3/8 Bolt
5		87615745		1	BRACKET, Aspirator Hose Support
6		9706690		1	NUT, M8, CI 8
7		86639313		1	WASHER, M8 x 20 x 1.6
8		87615743		1	HOSE, Tail Pipe To Aspirator
9		43127		1	BOLT, Hex, M8 x 25, 8.8
10		86625263		4	WASHER, M8 x 20 x 1.6
11		9628098		2	NUT, LOCK, M8 x 1.25, CI 10
12		87615741		1	BRACKET, Aspirator Mounting
13		84674		2	CLAMP, HOSE, #28, 1.31/2.25 Type F Worm
14		120104		1	BOLT, Hex, M8 x 20, 8.8
15		406089A2		1	VALVE, Aspirator Check
16		87615742		1	HOSE, Air Cleaner To Aspirator
17		86624194		1	CLAMP, HOSE, #36, 1.81/2.75 Type F Worm

440CT 440

AIR CLEANER - ENGINE

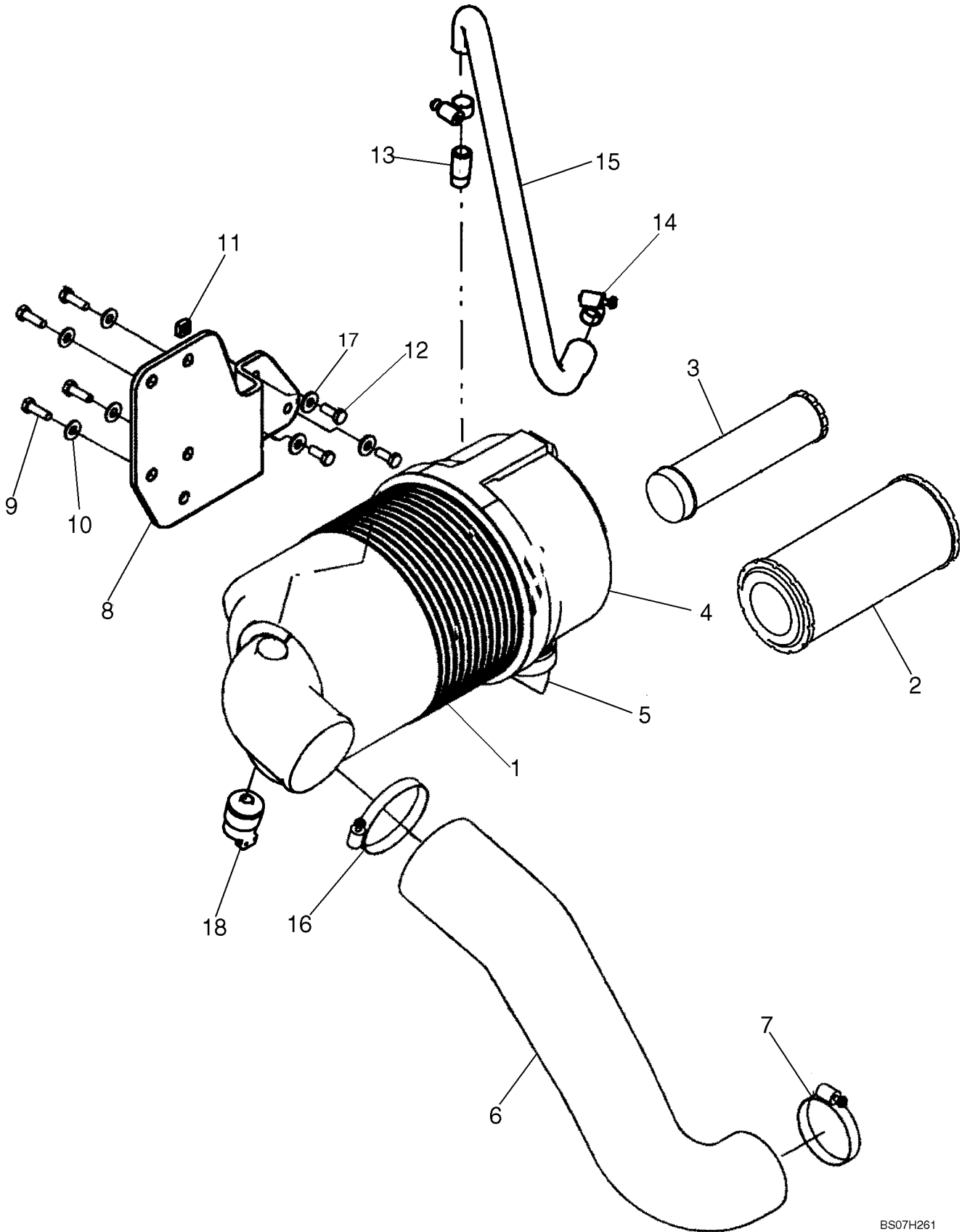

AIR CLEANER - ENGINE

REF	FN	PART NUMBER	YR/SN	QTY	DESCRIPTION
		87032107		1	CLEANER, Incl. 1 - 5
1		87041842		1	AIR CLEANER, Body
2		222421A1		1	FILTER, AIR, Primary
3		222422A1		1	FILTER, ELEMENT, Secondary
4		395792A1		1	COVER ASSY, Incl. 4A
4A		86990981		1	TAB, LOCKING, Not Illustrated Separately
5		A184597		1	POPPET, VALVE
6		87351957		1	HOSE, Air Cleaner Outlet
7		87040758		1	CLAMP, HOSE
8		87620930		1	BRACKET
9		43127		4	BOLT, Hex, M8 x 25, 8.8
10		86625263		4	WASHER, M8 x 20 x 1.6
11		87030567		3	NUT
12		120104		3	BOLT, Hex, M8 x 20, 8.8
13		L17985		1	FITTING
14		86625021		2	CLAMP, HOSE, #12, 0.69/1.25 Type F Worm
15		87352014		1	HOSE
16		381144		1	CLAMP, HOSE, #60, 3.31/4.25 Type F Worm
17		896-15008		3	WASHER, M8 x 21.5 x 2.5, HT
18		87013666		1	SWITCH, Air Restriction

440 440CT

ENGINE - MOUNTING

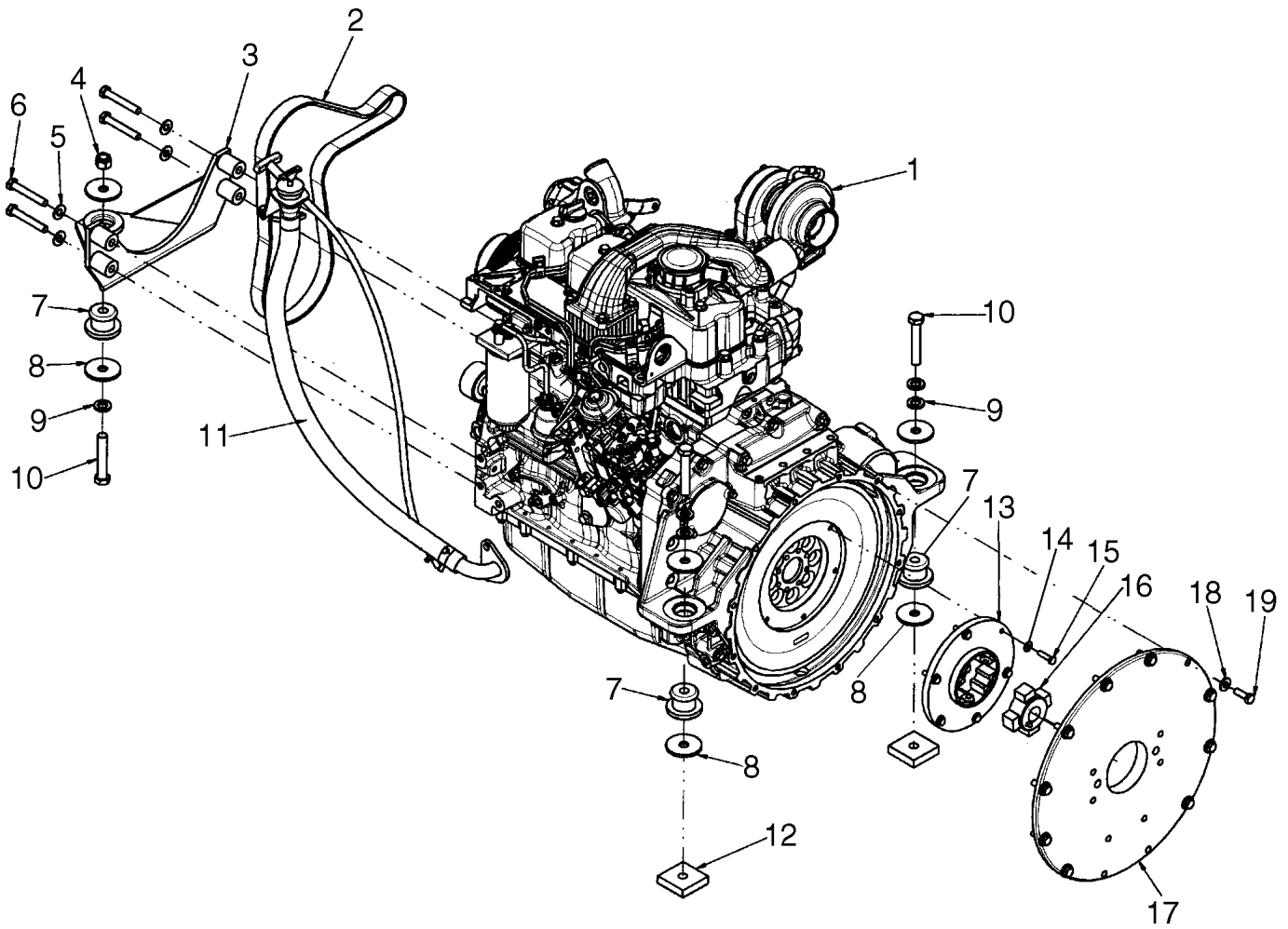

ENGINE - MOUNTING

REF	FN	PART NUMBER	YR/SN	QTY	DESCRIPTION
1		87384641		1	ENGINE, NEF, 67 KW 296 Fan; Incl Parts on Figures 02-09 - 02-41, 03-03 - 03-10, 04-02
2		85826230		1	BELT
3		87041763		1	MOUNT, ENGINE, Rear
4		412066		1	NUT, LOCK, M16 x 2, CI 8
5		140046		4	WASHER, SPRING, Belleville, M12
6		412085		4	BOLT, Hex, M12 x 80, 10.9
7		A140221		3	MOUNTING PARTS
8		87032338		6	WASHER, 21/32" x 2 1/2" x .188", HDN
9		86625266		5	WASHER, M17.5 x 30 x 4, HT
10		350616		3	BOLT, Hex, M16 x 90, 8.8
11		REF			INSTRUCTION, Dipstick Assy; See Figure 02-22
12		390350A1		2	PLATE
13		87024539		1	ELEMENT, Pump Drive, 6.5 in
14		322358		6	WASHER, SPRING, Belleville, M8
15		43235		6	BOLT, Hex, M8 x 30, 10.9
16		87024588		1	HUB, Pump Drive Star
17		87547003		1	PLATE, Pump Mounting
18		86639325		10	WASHER, M10 x 24.5 x 3, HT
19		43140		10	BOLT, Hex, M10 x 30, 8.8, Full Thd

440 440CT

ENGINE - MOUNTING (EUROPE)

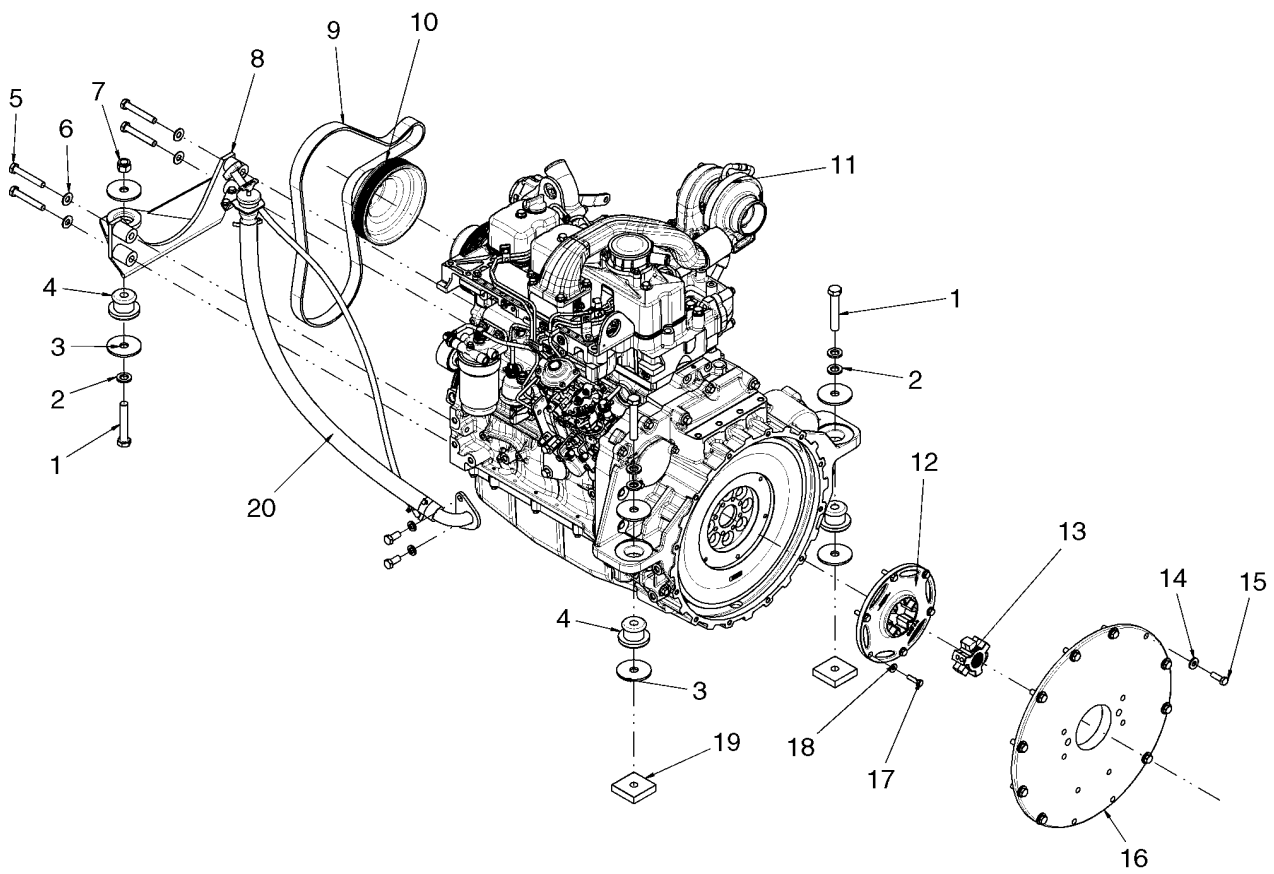

ENGINE - MOUNTING (EUROPE)

REF	FN	PART NUMBER	YR/SN	QTY	DESCRIPTION
1		350616		3	BOLT, Hex, M16 x 90, 8.8
2		86625266		5	WASHER, M17.5 x 30 x 4, HT
3		87687021		6	FASTENER
4		A140221		3	MOUNTING PARTS, Engine Mount
5		412085		4	BOLT, Hex, M12 x 80, 10.9
6		140046		4	WASHER, SPRING, Belleville, M12
7		412066		1	NUT, LOCK, M16 x 2, CI 8
8		87041763		1	MOUNT, ENGINE, Rear Engine Mount
9		87713059		1	BELT, Belt, V Ribbed (Europe)
10		87712652		1	PULLEY, Pulley (Europe)
11		87384641		1	ENGINE, Engine, NEF
12		87692685		1	COUPLING, Coupling, Flexible
13		87711337		1	COUPLING, Coupling, Drive Star
14		86639325		10	WASHER, M10 x 24.5 x 3, HT
15		43140		10	BOLT, Hex, M10 x 30, 8.8, Full Thd
16		87547003		1	PLATE, Pump Mounting Plate
17		43235		6	BOLT, Hex, M8 x 30, 10.9
18		322358		6	WASHER, SPRING, Belleville, M8
19		390350A1		2	PLATE
20		REF		1	INSTRUCTION, Oil Fill; See Fig 02-22

440CT 440

BUY NOW

**Then Instant Download
the Complete Manual
Thank you very much!**