

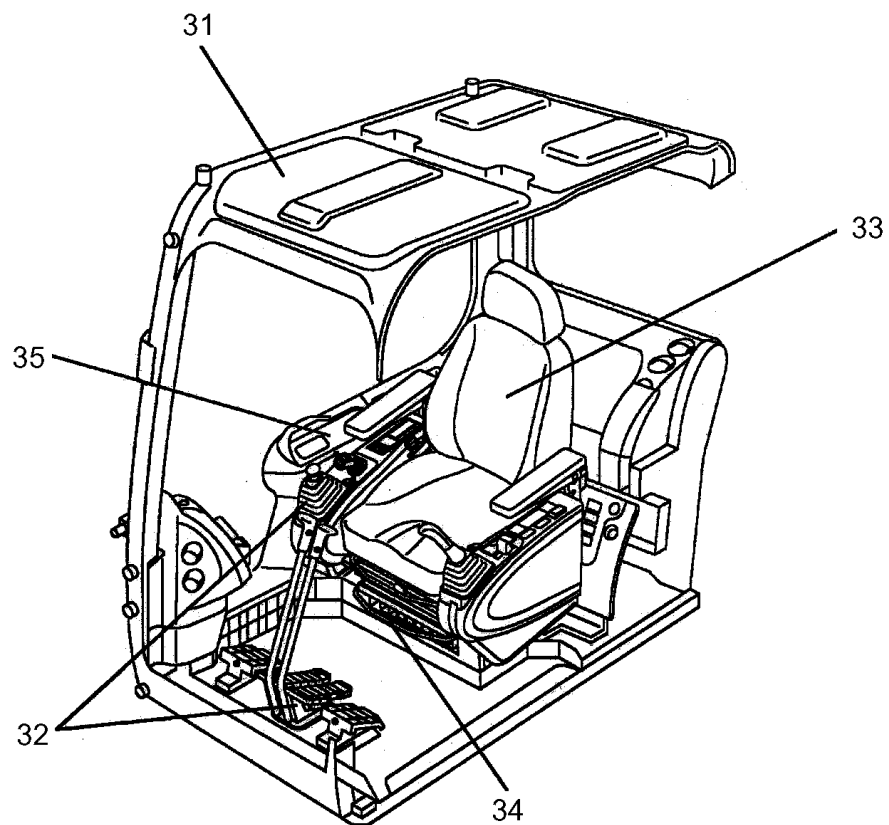

# PARTS CATALOGUE

CRAWLER EXCAVATOR  
CX180B  
TIER 3

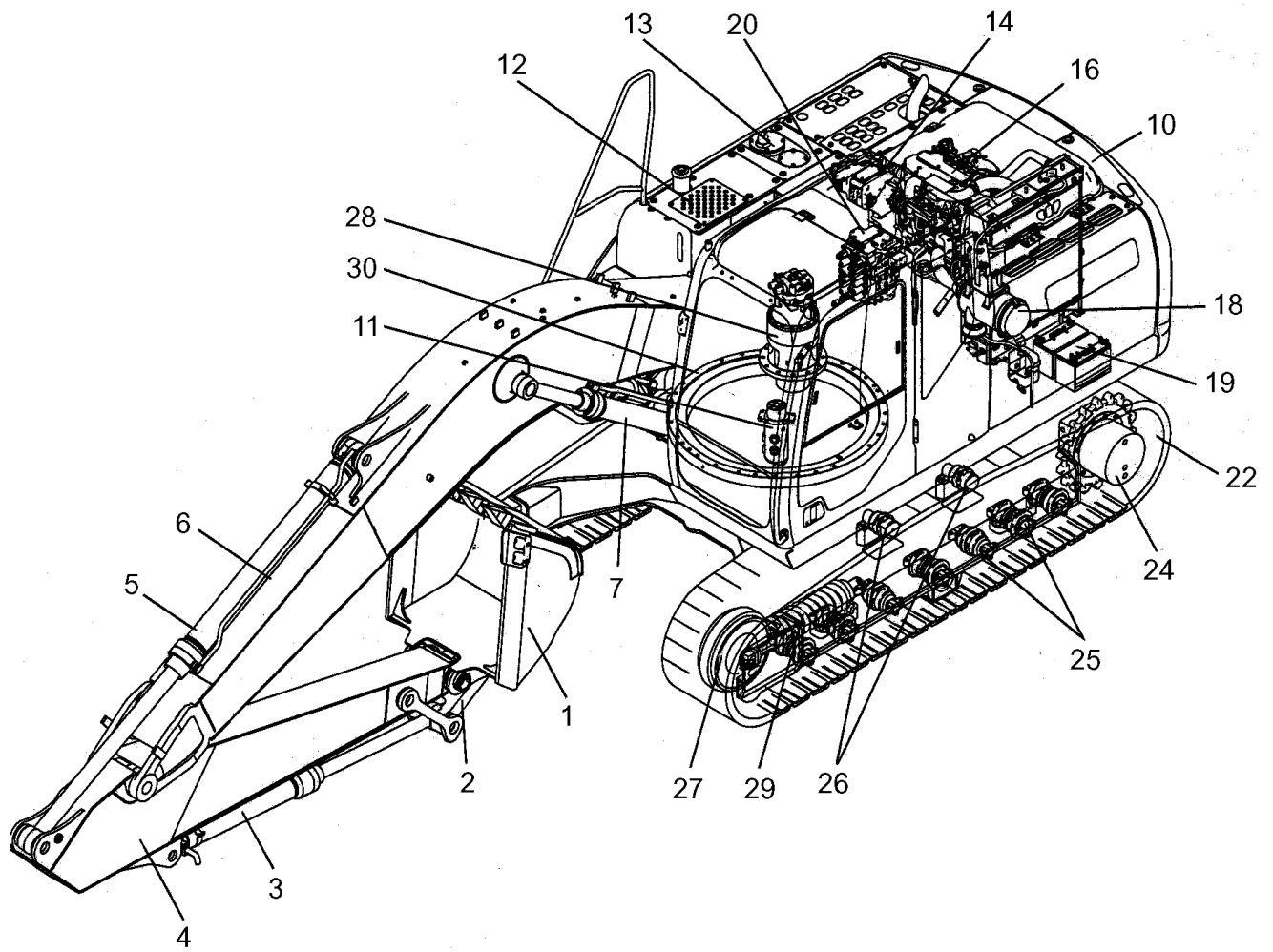

## CX180B CRAWLER EXCAVATOR TIER III (EUROPE) (1/07- )

## 00-001-00(01) COMPONENT INDEX

Ref	Part Number	Qty	Description
1		1	BUCKET - See Figure(s) 09-310-00 01 To 09-314-00 01
2		1	BUCKET CONTROL - See Figure(s) 09-300-00 01
3		1	BUCKET CYLINDER - See Figure(s) 08-021-00 01 To 08-23-01 01, 08-303-00 01
4		1	DIPPER - See Figure(s) 09-201-00 01 To 09-203-00 01
5		1	DIPPER CYLINDER - See Figure(s) 08-017-00 01 To 08-018-00 01, 08-302-00 01 To 08-302-02 01
6		1	MONOBLOCK BOOM - See Figure(s) 09-100-00 01
6		1	LINKER BOOM - See Figure(s) 09-100-01 01
7		1	BOOM CYLINDER - See Figure(s) 08-012-00 01 To 08-015-01 01, 08-300-00 01 To 08-301-02 01
8		1	UPPERSTRUCTURE CHASSIS - See Figure(s) 09-002-00 01, 09-003-00 01
9		1	COWLING - See Figure(s) 09-005-00 01 To 09-008-00 01
10		1	COUNTERWEIGHT CX160 - See Figure(s) 09-004-00 01
10		1	COUNTERWEIGHT CX180 - See Figure(s) 09-004-01 01
11		1	SWING JOINT - See Figure(s) 07-010-00 01
12		1	FUEL TANK, FUEL SYSTEM - See Figure(s) 03-001-00 01, 03-042-01 01
13		1	HYDRAULIC RESERVOIR, HYDRAULIC SYSTEM - See Figure(s) 08-001-00 01, 08-001-01 01, 08-004-00 01 To 08-046-00 01
14		1	HYDRAULIC PUMP - See Figure(s) 08-002-00 01, 08-003-00 01
15		1	EXHAUST ENGINE - See Figure(s) 02-003-00 01
16		1	ENGINE - See Figure(s) 02-001-00 01, 02-001-01 01, 02-005-01 01 To 02-110-01 01
17		1	RADIATOR - See Figure(s) 02-004-00 01, 02-005-00 01
18		1	AIR FILTRATION - See Figure(s) 02-002-00 01
19		1	BATTERIES, ELECTRICAL SYSTEM - See Figure(s) 04-001-00 01 To 04-825-01 01
20		1	CONTROL VALVE - See Figure(s) 08-200-00 01 To 08-205-02 01
21		1	UNDERCARRIAGE, HYDRAULIC CIRCUIT For CX160B - See Figure(s) 05-001-00 01, 07-001-00 01
21		1	UNDERCARRIAGE, HYDRAULIC CIRCUIT For CX180B - See Figure(s) 05-001-01 01, 07-001-01 01
22		1	TRACK FOOT STEP CX160B - See Figure(s) 05-005-00 01, 05-006-00 01, 05-007-00 01, 05-009-00 01
22		1	TRACK FOOT STEP CX180B - See Figure(s) 05-006-01 01, 05-007-01 01, 05-008-00 01, 05-009-01 01
23		1	GUIDE, CHAIN - See Figure(s) 05-011-00 01, 05-011-01 01
24		1	TRAVEL MOTOR AND REDUCTION GEAR CX160B - See Figure(s) 06-001-00 01, 06-010-00 01, 07-011-00 01, 07-012-00 01
24		1	TRAVEL MOTOR AND REDUCTION GEAR CX180B - See Figure(s) 06-001-01 01, 06-010-01 01, 07-011-01 01, 07-012-01 01
25		1	ROLLER LOWER - See Figure(s) 05-003-00 01
26		1	ROLLER UPPER - See Figure(s) 05-002-00 01
27		1	GUIDE PULLEY - See Figure(s) 05-004-00 01
28		1	SWING MOTOR-DRIVE REDUCTION GEAR - See Figure(s) 06-002-00 01, 06-011-00 01, 08-220-00 01
29		1	TENSION DAMPER CX160B - See Figure(s) 05-009-00 01
29		1	TENSION DAMPER CX180B - See Figure(s) 05-009-01 01
30		1	SWING COMPONENTS, LUBRICATION CIRCUIT - See Figure(s) 09-001-00 01
31		1	OPERATORS COMPARTMENT, CAB - See Figure(s) 04-011-00 01, 09-029-00 01 To 09-032-00 01
32		1	OPERATORS COMPARTMENT, LEVER, CONTROL - See Figure(s) 09-009-00 01
33		1	OPERATORS COMPARTMENT - SEAT AND CONTROL ARM MOUNTING - See Figure(s) 09-017-00 01 To 09-023-00 01
34		1	CAB AIR CONDITIONING - See Figure(s) 09-025-00 01 To 09-028-00 01

00-001-00(01) COMPONENT INDEX

Ref	Part Number	Qty	Description
35		1	SIDE INSTRUMENT PANEL - See Figure(s) 09-029-00 01

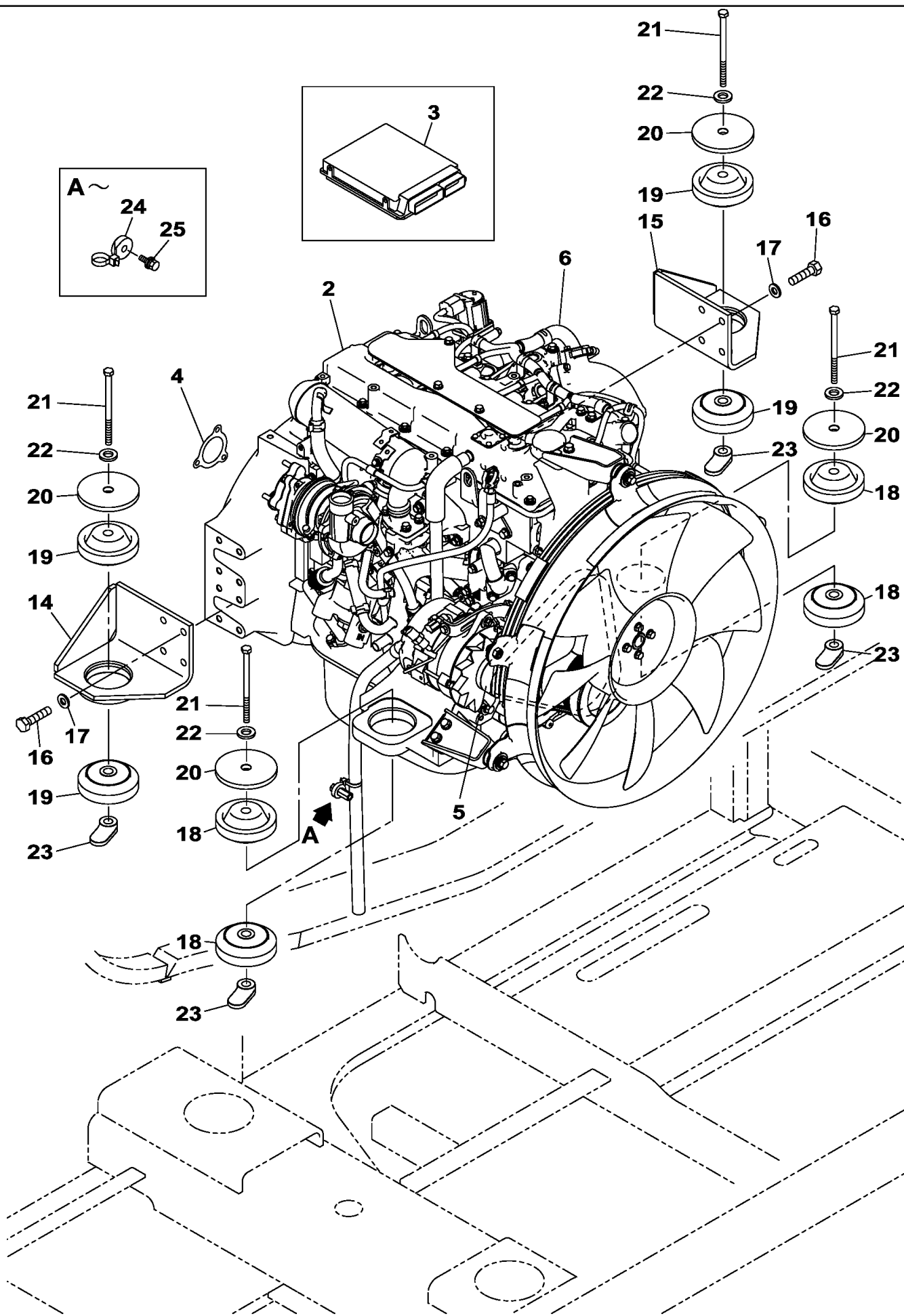

## CX180B CRAWLER EXCAVATOR TIER III (EUROPE) (1/07- )

## 02-001-00(01) ENGINE MOUNTING - ENGINE - OIL CIRCUIT

Ref	Part Number	Qty	Description
2	KLH10850	1	ENGINE, , Include(s) 3, 4, 5, 6; Also See Figure(s) 02-001-01 01 Ref. 7, 9, 11, 12, 13, Figure(s) 02-005-01 01 To 02- 826-01 01; 03-040-01 01 - 03-042-01 01, 04-060-01 01 To 04-815-01 01
3	REF	1	INSTRUCTION, , See Figure(s) 04-060-02 01 Ref.613
4	167913A1	1	GASKET,
5	REF	1	INSTRUCTION, , See Figure(s) 02-033-01 01 Ref. 36
6	REF	1	INSTRUCTION, , See Figure(s) 04-810-01 01 Ref.13
14	KNH10420	1	SILENTBLOC,
15	KNH10430	1	SILENTBLOC,
16	627-10035	8	BOLT, Hex, M10 x 35, 10.9, Full Thd,
17	150811A1	8	WASHER,
18	KNH10410	4	SILENTBLOC,
19	KNH10400	4	SILENTBLOC,
20	KRH10190	4	PLATE,
21	827-16130	4	BOLT, Hex, M16 x 130, 10.9,
22	150814A1	4	WASHER,
23	KRH1251	4	NUT,
24	KHR2584	1	CLAMP,
25	KHJ1215	4	SCREW, M8 x 25

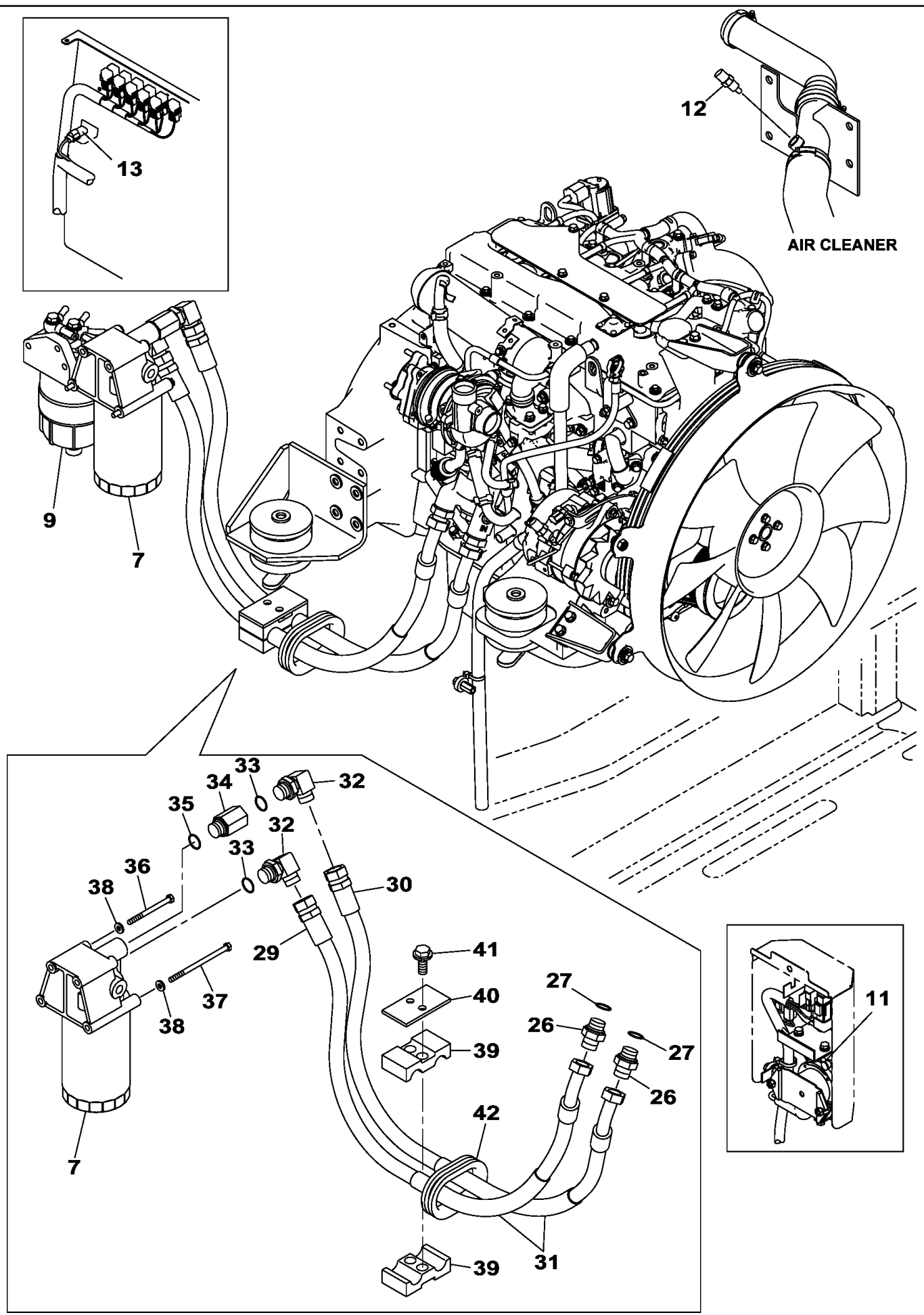

## CX180B CRAWLER EXCAVATOR TIER III (EUROPE) (1/07- )

## 02-001-01(01) ENGINE MOUNTING - ENGINE - OIL CIRCUIT

Ref	Part Number	Qty	Description
7	REF	1	INSTRUCTION, Oil Filter, See Figure(s) 02-050 01 01 Ref. 496
9	REF	1	INSTRUCTION, Fuel Filter, See Figure(s) 03-041-01 01 Ref. 1
11	REF	1	INSTRUCTION, Relay, See Figure(s) 04-060-02 01 ref. 424
12	REF	1	INSTRUCTION, Sensor, See Figure(s) 04-060-02 01 Ref. 608
13	REF	1	INSTRUCTION, Sensor, See Figure(s) 04-060-02 01 Ref. 796B
26	151654A1	2	CONNECTOR, HYD., 3/4" NPT O-Ring x 3/4" NPT, , Include(s) 27
27	154503A1	1	O-RING,
29	KLH10210	1	HOSE ASSY., 1250 mm
30	KLH10220	1	HOSE ASSY., 1350 mm
31	KBR0819	2	SHEATH, FLEXIBLE,
32	157580A1	2	ELBOW, 90e, 3/4" O-Ring x 3/4", , Include(s) 33
33	154503A1	1	O-RING,
34	152012A1	1	CONNECTOR, , Include(s) 35
35	154503A1	1	O-RING,
36	102R008Y110R	2	BOLT, M8 x 110
37	KHH0515	2	BOLT, M8 x 140
38	153081A1	4	WASHER,
39	KRH10200	2	CLAMP,
40	KRH10210	1	PLATE,
41	166052A1	2	BOLT, M10 x 25
42	KNJ2988	1	SEAL, RUBBER,



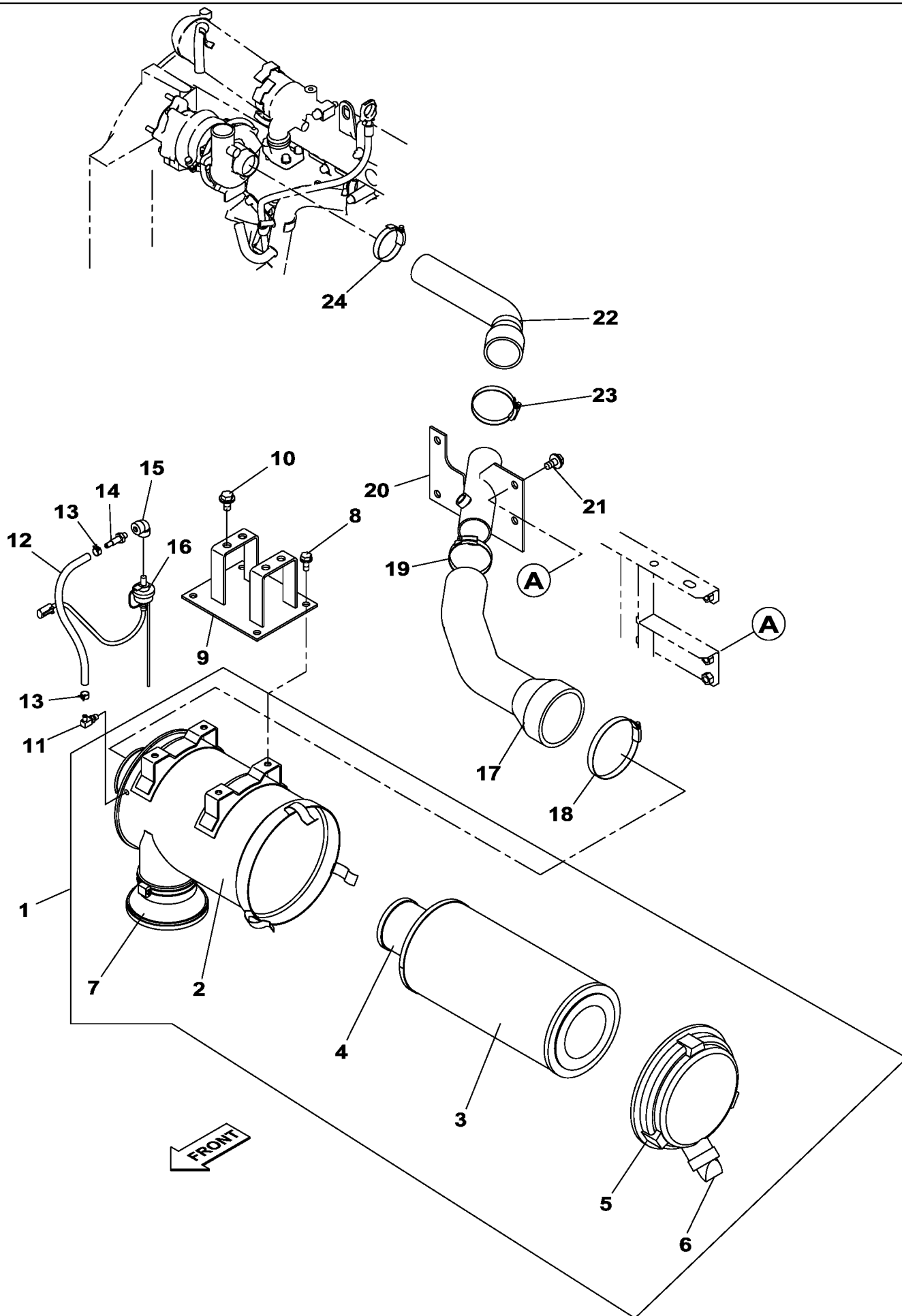

## CX180B CRAWLER EXCAVATOR TIER III (EUROPE) (1/07- )

## 02-002-00(01) AIR FILTRATION

Ref	Part Number	Qty	Description
1	KLH10150	1	FILTER ASSY., , Include(s) 2 - 7
2	NSS	1	NOT SERVICED SEPARATELY,
3	KLH10550	1	FILTER, AIR,
4	KLH10560	1	FILTER, AIR,
5	KLH10570	1	COVER,
6	KBH0924	1	VALVE,
7	165437A1	1	CAP,
8	166052A1	4	BOLT, M10 x 25
9	KLH10720	1	SUPPORT,
10	152718A1	4	BOLT,
11	KRH1237	1	ELBOW,
12	157169A1	1	HOSE, 300 mm
13	165951A1	2	CLAMP,
14	KRH1236	1	SEAL,
15	165818A1	1	ELBOW,
16	KHH10330	1	SENSOR,
17	KLH10510	1	HOSE, LARGE,
18	150545A1	1	CLAMP,
19	150736A1	1	CLAMP,
20	KLH10870	1	BRACKET,
21	152718A1	4	BOLT,
22	KNH10370	1	HOSE, LARGE,
23	150736A1	1	CLAMP,
24	165793A1	1	CLAMP,

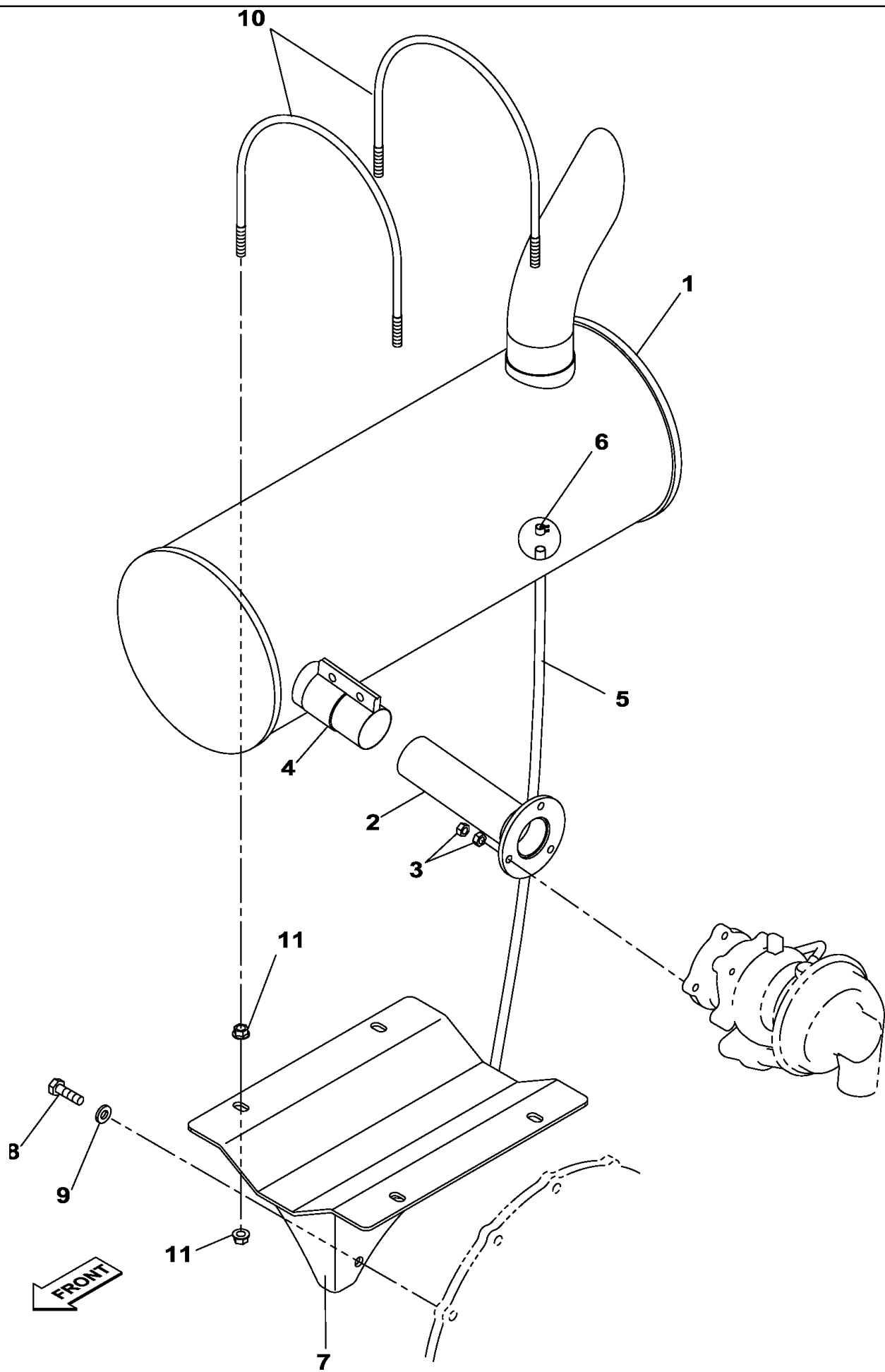

## CX180B CRAWLER EXCAVATOR TIER III (EUROPE) (1/07- )

## 02-003-00(01) EXHAUST

Ref	Part Number	Qty	Description
1	KLH10140	1	MUFFLER,
2	KLH10390	1	PIPE, EXHAUST SYSTEM,
3	829-1408	6	NUT, M8, CI 10,
4	KEH0326	1	CLAMP,
5	157478A1	1	TUBE, 800 mm
6	165952A1	1	MOUNTING CLIP,
7	KLH10400	1	BRACKET,
8	627-10035	3	BOLT, Hex, M10 x 35, 10.9, Full Thd,
9	150409A1	3	WASHER,
10	KHH11390	2	U-BOLT, M10
11	KHH11440	8	NUT, M10

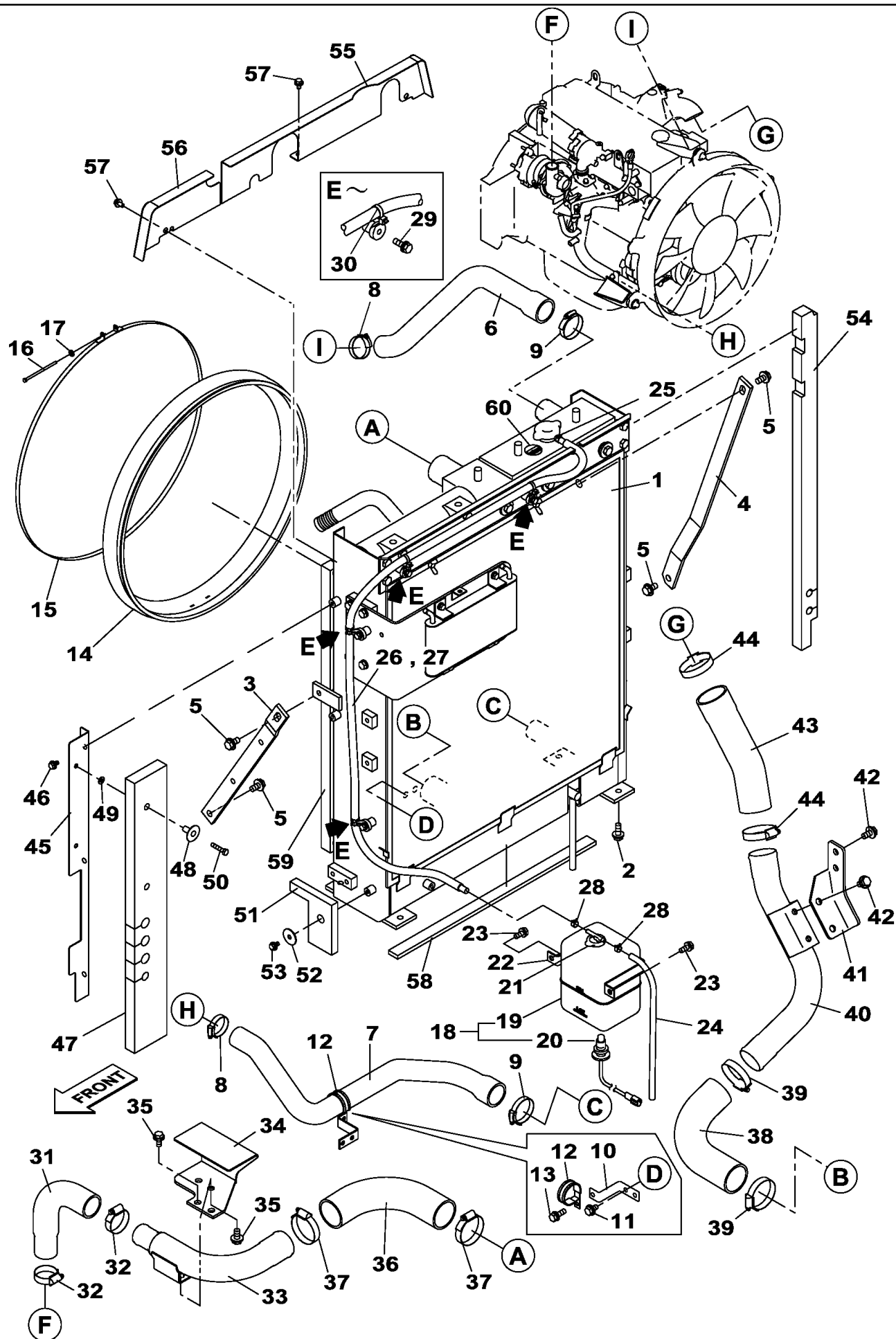

## CX180B CRAWLER EXCAVATOR TIER III (EUROPE) (1/07- )

## 02-004-00(01) ENGINE WATER CIRCUIT

Ref	Part Number	Qty	Description
1	KNH10450	1	RADIATOR, , See Figure(s) 02-005-00 01
2	166352A1	4	BOLT, M12 x 30
3	KLH10890	1	STAY,
4	KLH10240	1	STAY,
5	152718A1	4	BOLT,
6	KNH10210	1	HOSE, LARGE,
7	KLH10260	1	HOSE, LARGE,
8	165792A1	2	CLAMP,
9	165793A1	2	CLAMP,
10	KLH10270	1	SUPPORT,
11	166345A1	2	BOLT, M8 x 16
12	KLH10280	1	COLLAR CLAMP,
13	KHJ1215	1	SCREW, M8 x 25
14	KLH10900	1	SEAL, RUBBER,
15	KLH10300	1	BAND,
16	KRH1377	1	SCREW, M5 x 100
17	895-11005	1	WASHER, M5 x 10 x 1,
18	KHH10840	1	RESERVOIR, COOLANT EXPNSN, , Include(s) 19, 20
19	NSS	1	NOT SERVICED SEPARATELY, Tank
20	161740A1	1	SWITCH,
21	KHH10860	1	PLASTIC PLUG,
22	KRH1270	1	HOLDER,
23	166052A1	2	BOLT, M10 x 25
24	KHH11740	1	HOSE, 400 mm
25	165951A1	1	CLAMP,
26	KHH0517	1	HOSE, 1900 mm
27	KBR0838	1	LOOM, 1800 mm
28	165951A1	2	CLAMP,
29	KHJ1215	4	SCREW,
30	KHR2584	4	CLAMP, M8 x 25
31	KLH10310	1	HOSE, LARGE,
32	164966A1	2	CLIP, HOSE,
33	KNH10230	1	DUCT, AIR,
34	KLH10790	1	SUPPORT,
35	152718A1	4	BOLT,
36	KLH10320	1	HOSE, LARGE,
37	164967A1	2	CLAMP,
38	KLH10330	1	HOSE, LARGE,
39	164967A1	2	CLAMP,
40	KLH10360	1	DUCT, AIR,
41	KLH10380	1	SUPPORT,
42	152718A1	4	BOLT,
43	KLH10340	1	HOSE, LARGE,
44	164967A1	2	CLAMP,
45	KLH10410	1	SUPPORT,

## CX180B CRAWLER EXCAVATOR TIER III (EUROPE) (1/07- )

## 02-004-00(01) ENGINE WATER CIRCUIT

Ref	Part Number	Qty	Description
46	166345A1	3	BOLT, M8 x 16
47	KLH10430	1	SEAL PROTECTION,
48	KHH0358	2	RETAINER,
49	895-11008	2	WASHER, M8 x 16 x 1.6,
50	827-8040	2	BOLT, Hex, M8 x 40, 10.9,
51	KLH10440	1	SEAL PROTECTION,
52	163356A1	1	WASHER,
53	166345A1	1	BOLT, M8 x 16
54	KLH10800	1	SEAL PROTECTION,
55	KLH10740	1	SUPPORT,
56	KLH10750	1	SUPPORT,
57	166345A1	6	BOLT, M8 x 16
58	KLH10480	1	SEAL PROTECTION,
59	KLH10880	1	SEAL PROTECTION,
60	162468A1	1	DECAL,

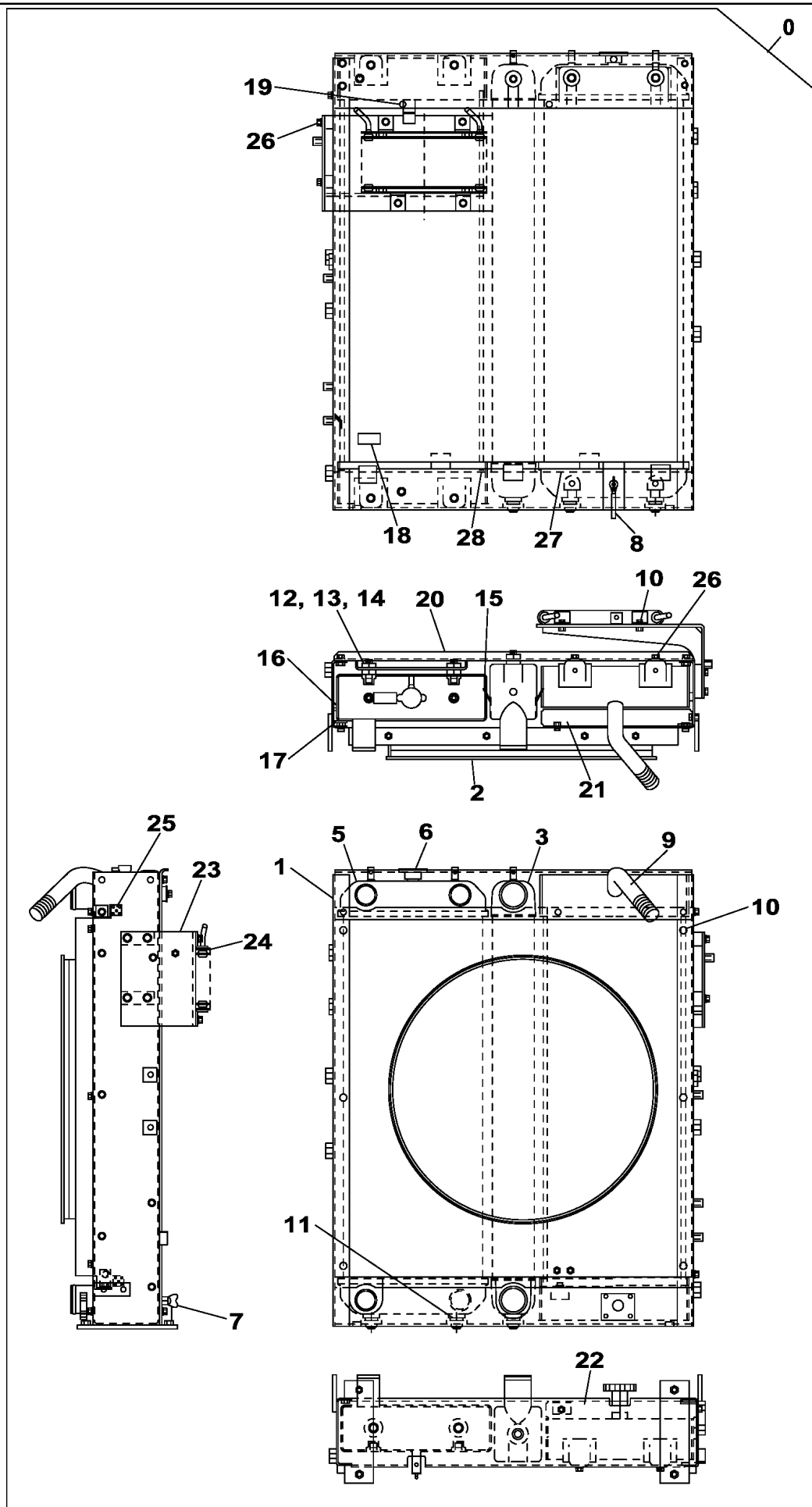



## CX180B CRAWLER EXCAVATOR TIER III (EUROPE) (1/07- )

## 02-005-00(01) RADIATOR

Ref	Part Number	Qty	Description
0	KNH10450	1	RADIATOR, , Include(s) 1 - 28
1	LT001670	1	FRAME,
2	LG006180	1	SHROUD,
3	LN002010	1	INTERCOOLER,
5	NSS	1	NOT SERVICED SEPARATELY,
6	LR015830	1	CAP, RADIATOR,
7	LK00283	1	FAUCET,
8	LK00284	1	HOSE, FLEXIBLE,
9	LN002040	1	COOLER, OIL,
10	LA011210	18	SCREW,
11	LQ000370	3	SEAL, RUBBER,
12	LQ000380	3	SEAL, RUBBER,
13	LH005030	3	COLLAR,
14	LA011220	3	SCREW,
15	LE015320	2	SEAL PROTECTION,
16	TE00881	2	SEAL PROTECTION,
17	LE015330	1	SEAL PROTECTION,
18	LJ015240	2	FILTER,
19	LUG0096	2	SCREW,
20	LS003460	1	SUPPORT,
21	LS003470	1	SUPPORT,
22	LS003480	1	BRACKET,
23	LS003490	1	BRACKET,
24	LN002050	1	COOLER,
25	LE015340	2	SEAL PROTECTION,
26	LA011230	8	SCREW,
27	LE015350	2	SEAL PROTECTION,
28	LE015360	1	SEAL PROTECTION,

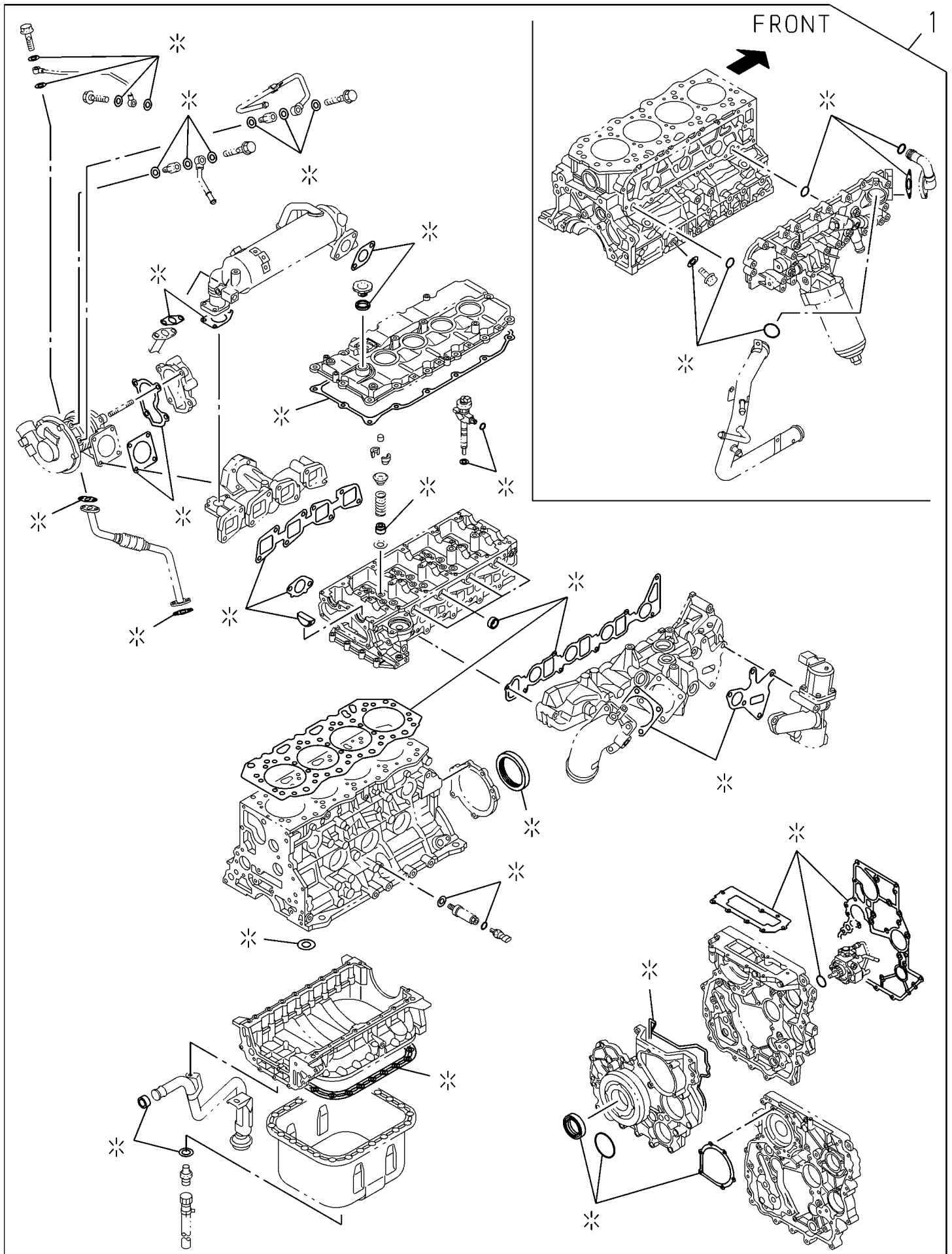

## CX180B CRAWLER EXCAVATOR TIER III (EUROPE) (1/07- )

## 02-005-01(01) PACKAGE SEALS - ENGINE

Ref	Part Number	Qty	Description
1	87595254	1	GASKET, , With Gasket Cylinder Head T=1.05
1	87595256	1	GASKET, , With Gasket Cylinder Head T= 1.10
1	87595259	1	GASKET, , With Gasket Cylinder Head T= 1.15

2

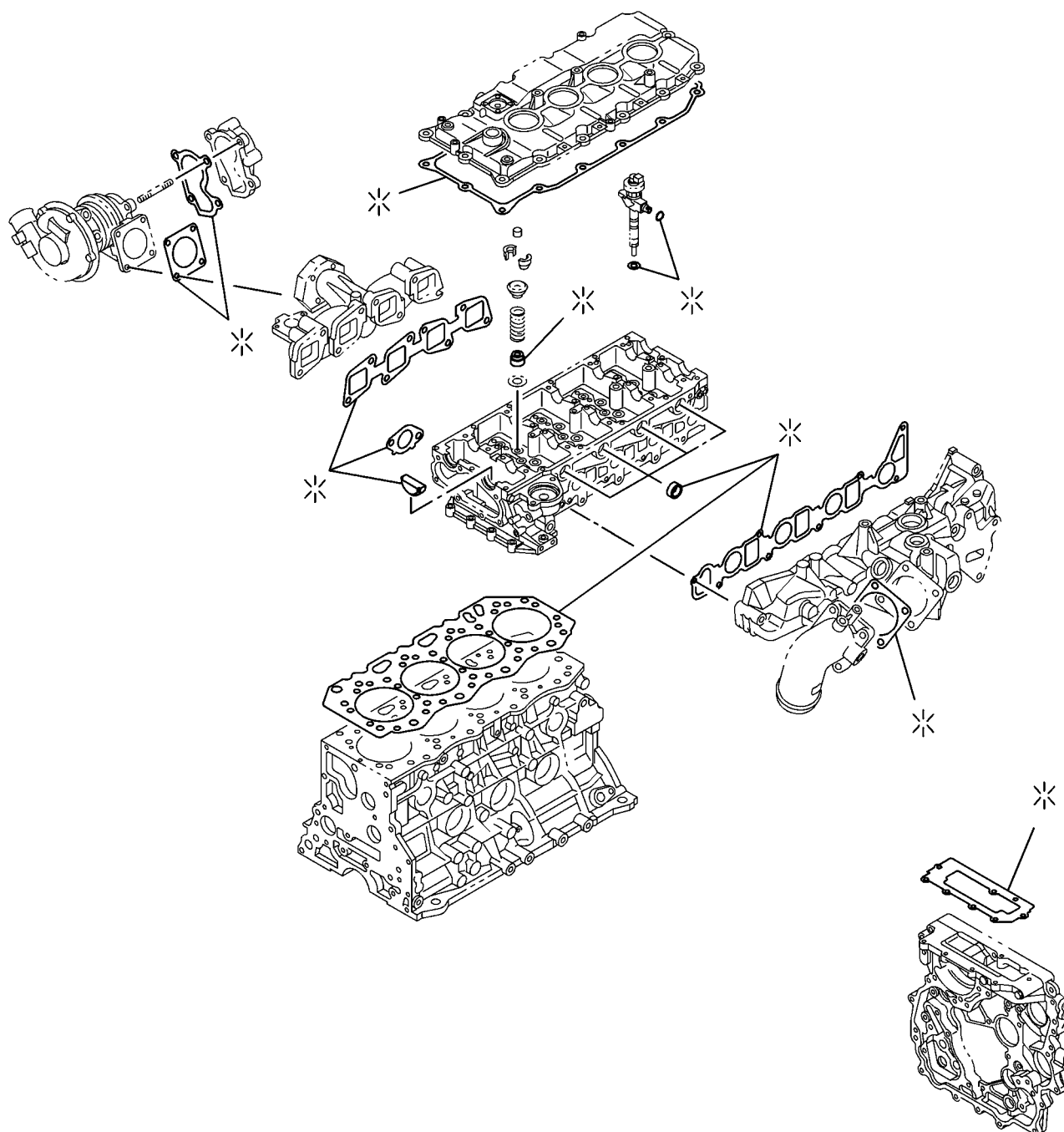

## CX180B CRAWLER EXCAVATOR TIER III (EUROPE) (1/07- )

## 02-005-02(01) PACKAGE SEALS - ENGINE

Ref	Part Number	Qty	Description
2	87595260	1	GASKET, , With Gasket Cylinder Head T=1.475
2	87595262	1	GASKET, , With Gasket Cylinder Head T=1.525
2	87595264	1	GASKET, , With Gasket Cylinder Head T=1.572

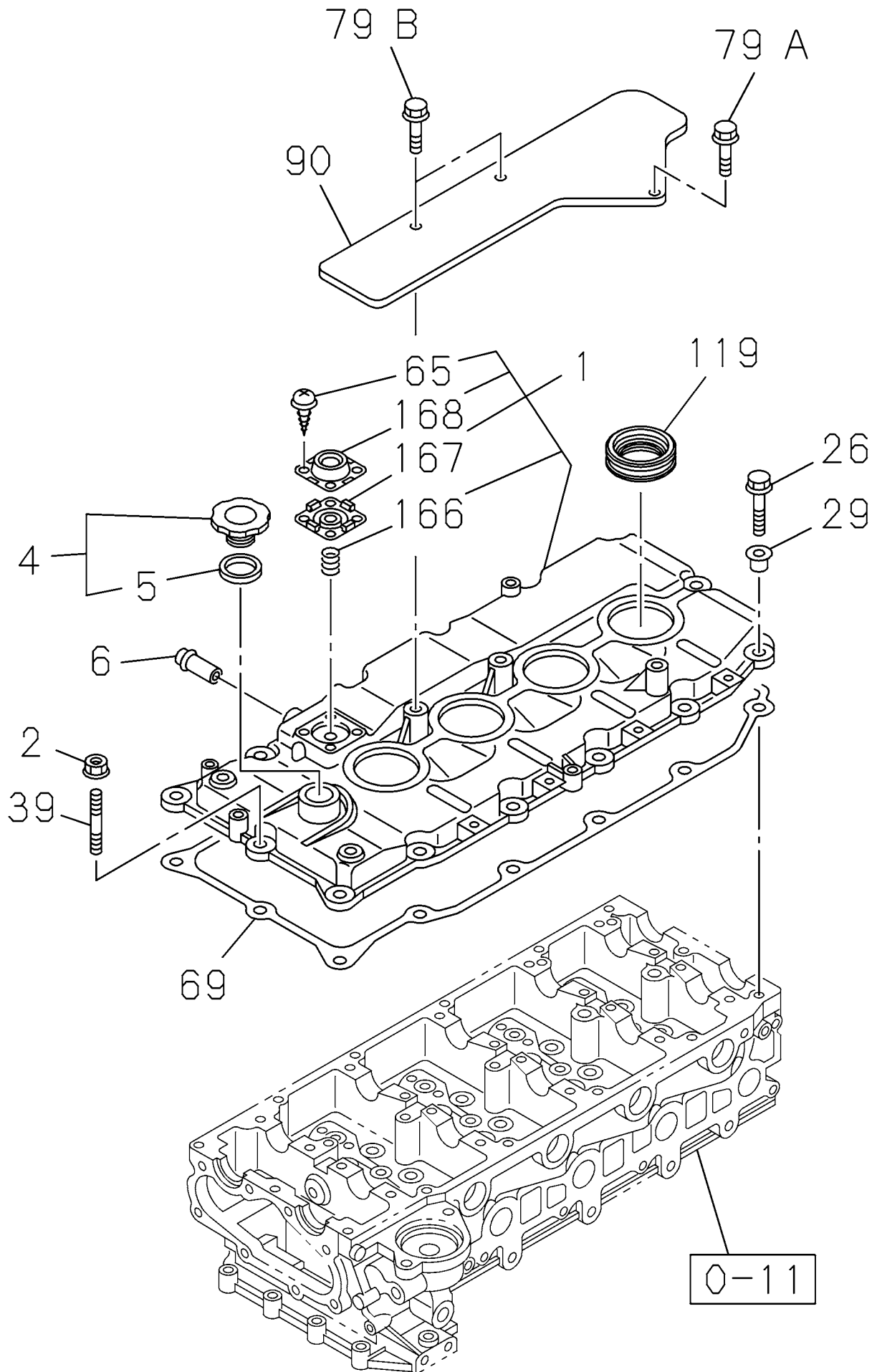

## CX180B CRAWLER EXCAVATOR TIER III (EUROPE) (1/07- )

## 02-010-01(01) COVER - CYLINDER HEAD

Ref	Part Number	Qty	Description
0-11	REF	1	INSTRUCTION, , See Figure(s) 02-011-01 01
1	87595265	1	COVER, , Include(s) 65, 166 - 168
2	87595267		NUT,
4	353965A1	1	CAP, FILLER, , Include(s) 5
5	353966A1	2	SEAL,
6	87595269	1	PIPE,
26	87595272	13	SCREW,
29	87595273	14	SEAL, RUBBER,
39	87595274	1	STUD,
65	87595289	4	SCREW, ADJUSTMENT,
69	87595291	1	GASKET,
79A	87595292	1	SCREW,
79B	87595323	2	SCREW,
90	87595356	1	COVER,
119	87595387	4	COVER,
167	87595390	1	DIAPHRAGM,
168	87595391	1	COVER,





## CX180B CRAWLER EXCAVATOR TIER III (EUROPE) (1/07- )

## 02-011-01(01) CYLINDER HEAD

Ref	Part Number	Qty	Description
1	87595392	1	CYLINDER HEAD, , Include(s) 4, 5A, 5B, 7A - 7C, 39, 143, Also See Figure(s) 02-011-02 01
2A	87595394	1	GASKET, T=1.05
2B	87595407	1	GASKET, T=1.10
2C	87595412	1	GASKET, T=1.15
3	87595413	18	SCREW,
4	87595424	16	GUIDE, VALVE,
5A	87595425	8	SEAT, VALVE,
5B	87595431	8	SEAT, VALVE,
7A	87384455	2	CUPEL,
7B	76609741	13	PLUG,
7C	87595433	7	CUPEL,
10	438043A1	4	PLUG,
11	87595811	1	CONNECTOR, ELEC,
143	87595822	20	SCREW,
155	87595825	4	SCREW,
172	87595827	1	PLATE,
192	87595807	4	NUT,

**BUY NOW**

**Then Instant Download  
the Complete Manual  
Thank you very much!**