

## CX460 CASE CRAWLER EXCAVATOR (EUROPE)

## 02-003-00(01) ENGINE - ENGINE MOUNTING

Ref	Part Number	Qty	Description
2	KTH0660	1	ENGINE ASSY, , See Page(s) 02-019-00-01 To 02-061-00-01, 03-011-00-01 To 03-033-00-01, 04-029-00-01
11	KTH0656	1	SUPPORT,
12	KTH0657	1	SUPPORT,
13	827-10040	12	BOLT, Hex, M10 x 40, 10.9, Full Thd, M10 x 40; 10.9
14	150409A1	12	WASHER, 10,5 x 21 x 3,2 mm
15	KSH0497	2	SPACER,
16	150874A1	6	WASHER,
17	KTH0566	4	INSULATOR BLOCK,
18	KTH0567	4	INSULATOR BLOCK,
19	827-20150	2	BOLT, Hex, M20 x 150, 10.9, M20 x 150; 10.9
20	102R020Y260R	2	BOLT,
21	150817A1	8	WASHER,
22	162R020VR	2	NUT,
23	KSH0923	2	NUT,
24	150860A1	1	CLAMP,
25	840-168	1	SCREW, Cross Pan Hd, M6 x 8, M6 x 8; 4.8
26	150067A1	1	STRAP,
27	827-12050	4	BOLT, Hex, M12 x 50, 10.9, M12 x 50; 10.9
28	183-112VR	4	WASHER, SPRING,

Until DC46B... Tier 2



## CX460 CASE CRAWLER EXCAVATOR (EUROPE)

## 02-003-00(02) ENGINE - ENGINE MOUNTING

Ref	Part Number	Qty	Description
1	KTH0660	1	ENGINE ASSY, , Consists Of Ref. 3 To 10, Also Page(s) 02-019-00-01 To 02-061-00-01, 03-011-00-01 To 03-033-00-01, 04-029-00-01 To 04-033-00 01
3	REF	1	INSTRUCTION, Motor, See Page(s) 04-029-00 01 Ref. 488
4	REF	1	INSTRUCTION, Gasket, See Page(s) 02-007-00 01 Ref. 12
5	REF	1	INSTRUCTION, Relay, See Page(s) 04-029-00 01 Ref. 424
6	REF	1	INSTRUCTION, Oil Filter, See Page(s) 02-037-00 01 Ref. 2
7	REF	1	INSTRUCTION, Oil Filter, See Page(s) 02-041-00 01 Ref. 391
8	REF	1	INSTRUCTION, Fuel Filter, See Page(s) 03-015-00 01 Ref. 58
9	REF	1	INSTRUCTION, Belt, See Page(s) 02-017-00 01 Ref. 36
10	REF	1	INSTRUCTION, Controler, See Page(s) 04-029-00 01 Ref. 478
11	KTH0656	1	SUPPORT,
12	KTH0657	1	SUPPORT,
13	827-10040	12	BOLT, Hex, M10 x 40, 10.9, Full Thd, M10 x 40; 10.9
14	150409A1	12	WASHER, 10,5 x 21 x 3,2 mm
15	KSH0497	2	SPACER,
16	150874A1	6	WASHER,
17	KTH0566	4	INSULATOR BLOCK,
18	KTH0567	4	INSULATOR BLOCK,
19	827-20150	2	BOLT, Hex, M20 x 150, 10.9, M20 x 150; 10.9
20	102R020Y260R	2	BOLT,
21	150817A1	8	WASHER,
22	162R020VR	2	NUT,
23	KSH0923	2	NUT,
24	150860A1	1	CLAMP,
25	840-168	1	SCREW, Cross Pan Hd, M6 x 8, M6 x 8; 4.8
26	150067A1	1	STRAP,
27	827-12050	4	BOLT, Hex, M12 x 50, 10.9, M12 x 50; 10.9
28	183-112VR	4	WASHER, SPRING,

DC46B... Tier 2 And After

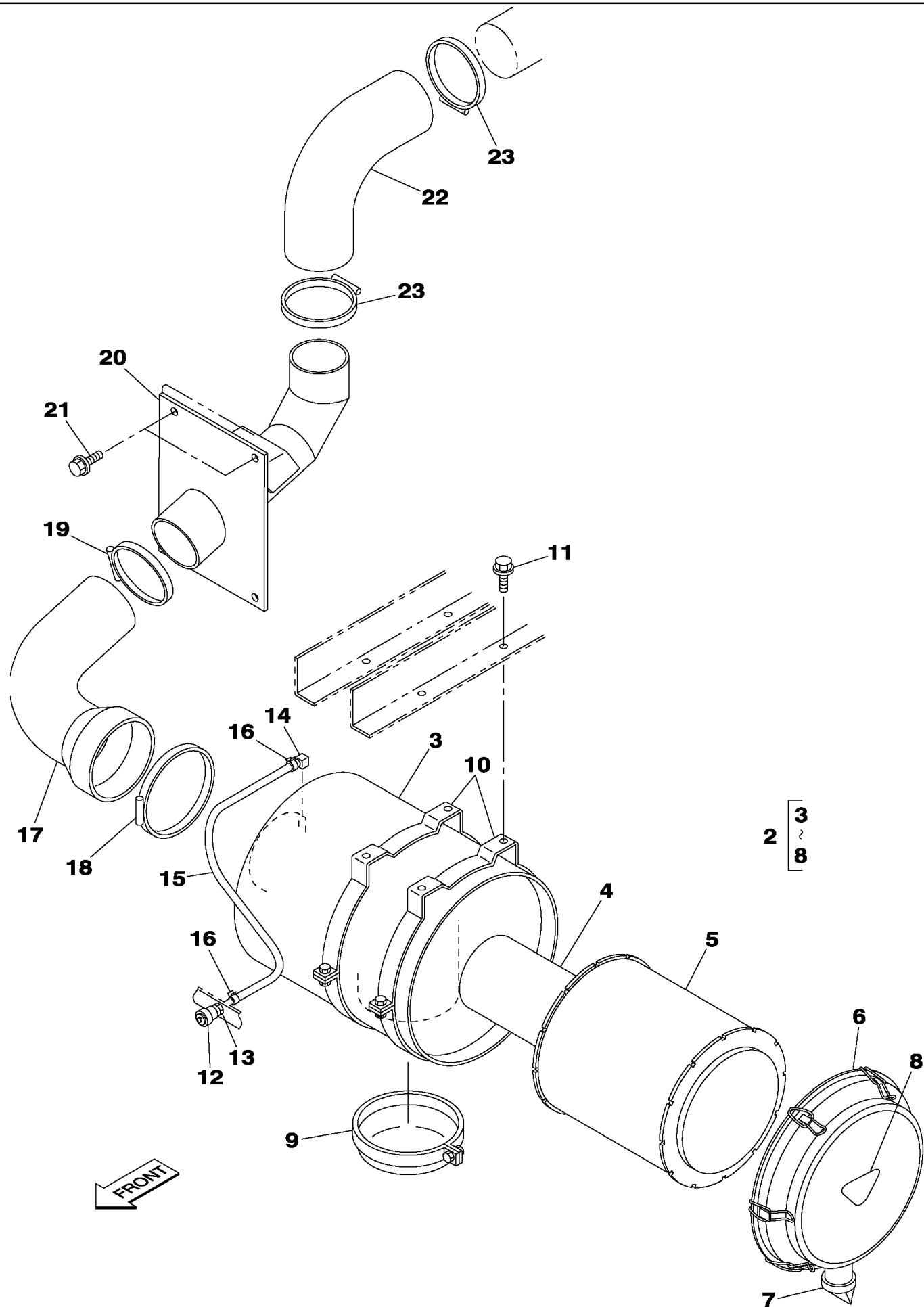

## CX460 CASE CRAWLER EXCAVATOR (EUROPE)

## 02-005-00(01) AIR FILTRATION

Ref	Part Number	Qty	Description
2	KTH0574	1	AIR CLEANER, , Consists of Ref Numbers 3 To 8
3	KTH0575	1	BODY,
4	KTH0576	1	FILTER, ELEMENT, , Secondary
5	KTH0577	1	FILTER, ELEMENT, , Primary
6	KTH0578	1	COVER,
7	KTH0579	1	VALVE,
8	NSS	1	NOT SERVICED SEPARATELY,
9	KTH0545	1	CAP,
10	KUH0027	2	STRIP, FIXING,
11	166052A1	4	BOLT,
12	KSH0050	1	INDICATOR,
13	KRH1236	1	SEAL,
14	KRH1237	1	ELBOW,
15	157776A1	1	HOSE,
16	165951A1	2	CLAMP,
17	KTH0591	1	HOSE, LARGE,
18	158840A1	1	BAND,
19	150855A1	1	CLAMP,
20	KTH0647	1	BRACKET,
21	152718A1	2	BOLT,
22	KTH0593	1	HOSE, LARGE,
23	150545A1	2	CLAMP,

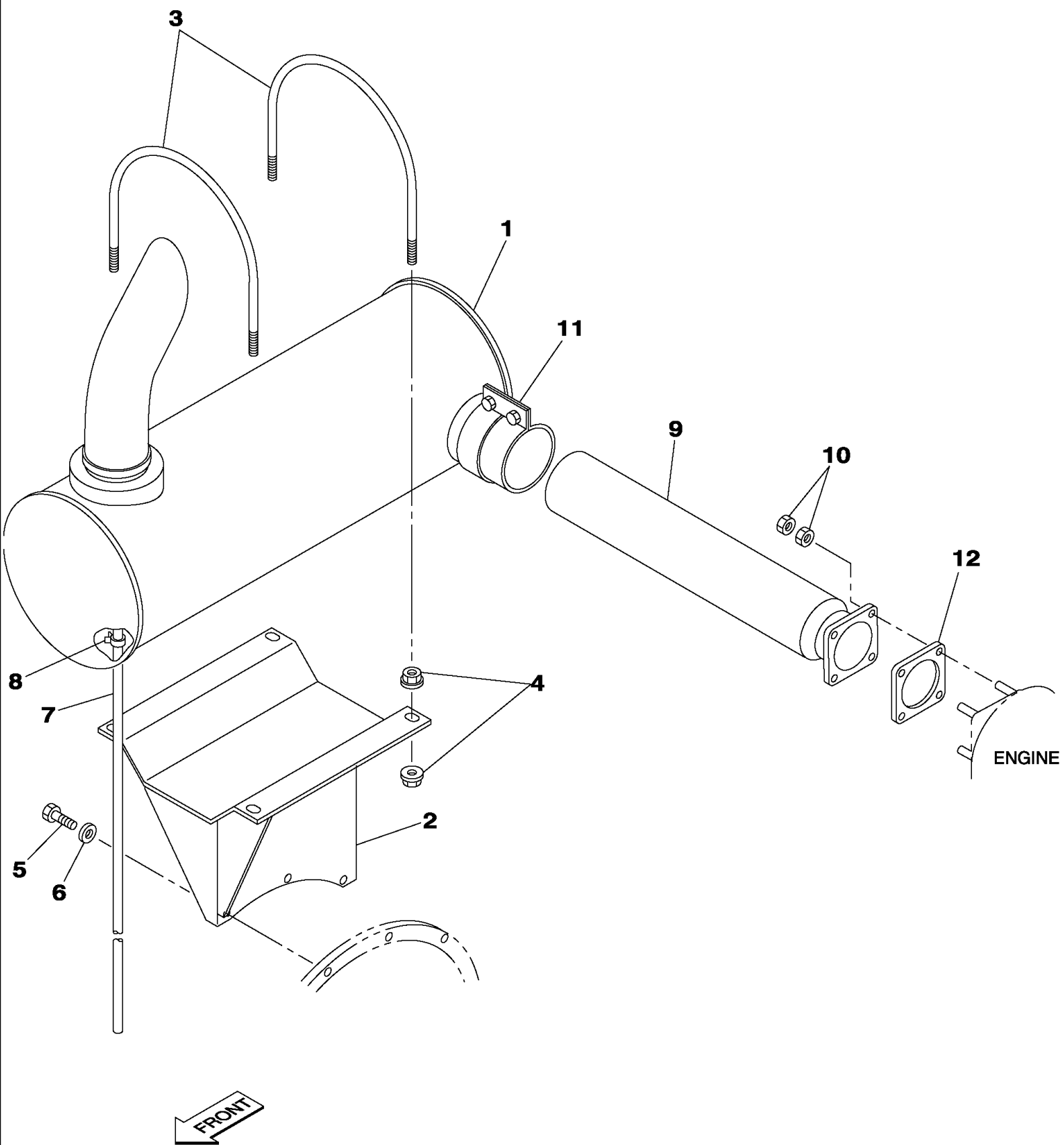

## CX460 CASE CRAWLER EXCAVATOR (EUROPE)

## 02-007-00(01) EXHAUST

Ref	Part Number	Qty	Description
1	KTH0639	1	MUFFLER,
2	KTH0641	1	HOLDER,
3	KBH0850	2	U-BOLT,
4	150472A1	8	NUT,
5	827-10050	3	BOLT, Hex, M10 x 50, 10.9, M10 x 50; 10.9
6	150409A1	3	WASHER, 10,5 x 21 x 3,2 mm
7	150668A1	1	TUBE, 1050mm (41-3/8 in)
8	165952A1	1	MOUNTING CLIP,
9	KTH0648	1	PIPE,
10	153856A1	8	NUT,
11	KSH0951	1	COLLAR ASSY.,
12	KTH0615	1	GASKET,



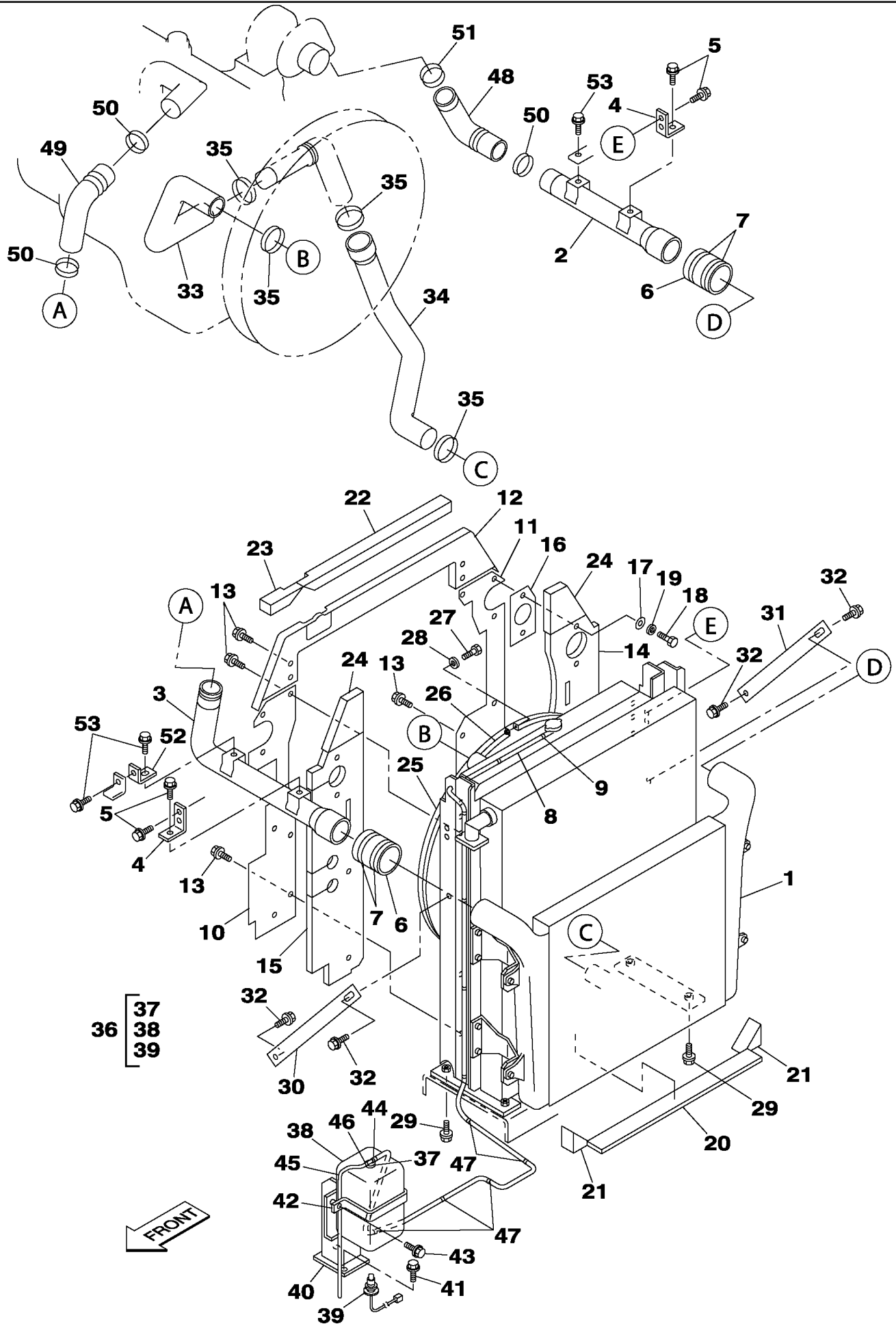

## CX460 CASE CRAWLER EXCAVATOR (EUROPE)

## 02-009-00(01) WATER CIRCUIT - RADIATOR

Ref	Part Number	Qty	Description
1	KTH0568	1	RADIATOR, , See Page(s) 02-013
2	KTH0637	1	HOSE, LARGE,
3	KTH0638	1	HOSE, LARGE,
4	KTH0614	2	BRACKET,
5	152718A1	6	BOLT,
6	KTH0635	2	HOSE, LARGE,
7	150294A1	4	CLIP,
8	KHH0437	1	HOSE,
9	165951A1	1	CLAMP,
10	KTH0601	1	BRACKET,
11	KTH0602	1	BRACKET,
12	KTH0603	1	BRACKET,
13	152718A1	10	BOLT,
14	KTH0604	1	SHEET, SEAL,
15	KTH0605	1	SHEET, SEAL,
16	KTH0608	1	PAD, RUBBER,
17	KHH0358	8	RETAINER,
18	627-8040	8	BOLT, Hex, M8 x 40, 10.9, Full Thd,
19	895-11008	8	WASHER, M8 x 16 x 1.6, 9 x 17 x 1,6 mm
20	KTH0606	1	GASKET,
21	KTH0607	2	GASKET,
22	KTH0644	1	SHEET, SEAL,
23	KTH0645	1	SHEET, SEAL,
24	KTH0646	2	SHEET, SEAL,
25	KTH0632	1	BAND,
26	KTH0633	1	BAND,
27	KRH1377	1	SCREW,
28	895-11005	1	WASHER, M5 x 10 x 1, 5,5 x 10 x 1 mm
29	166373A1	4	BOLT,
30	KTH0595	1	BRACKET,
31	KTH0596	1	BRACKET,
32	166373A1	4	BOLT,
33	KTH0597	1	HOSE, FLEXIBLE,
34	KTH0598	1	HOSE, LARGE,
35	165795A1	4	CLAMP,
36	160639A1	1	RESERVOIR, COOLANT EXPNSN, , Consists of Ref Numbers 37 To 39
37	161740A1	1	SWITCH,
38	161847A1	1	RESERVOIR, COOLANT EXPNSN,
39	161848A1	1	PLUG,
40	KTH0599	1	BRACKET,
41	152718A1	2	BOLT,
42	KTH0600	1	HOLDER,
43	166052A1	1	BOLT,
44	165951A1	1	CLAMP,
45	157485A1	1	HOSE, 600mm (23-5/8 in)

## CX460 CASE CRAWLER EXCAVATOR (EUROPE)

## 02-009-00(01) WATER CIRCUIT - RADIATOR

Ref	Part Number	Qty	Description
46	165952A1	1	MOUNTING CLIP,
47	KHR2787	5	CLAMP,
48	KTH0634	1	HOSE, LARGE,
49	KTH0636	1	HOSE, LARGE,
50	164968A1	3	CLAMP,
51	164967A1	1	CLAMP,
52	KTH0613	1	BRACKET,
53	152718A1	3	BOLT,

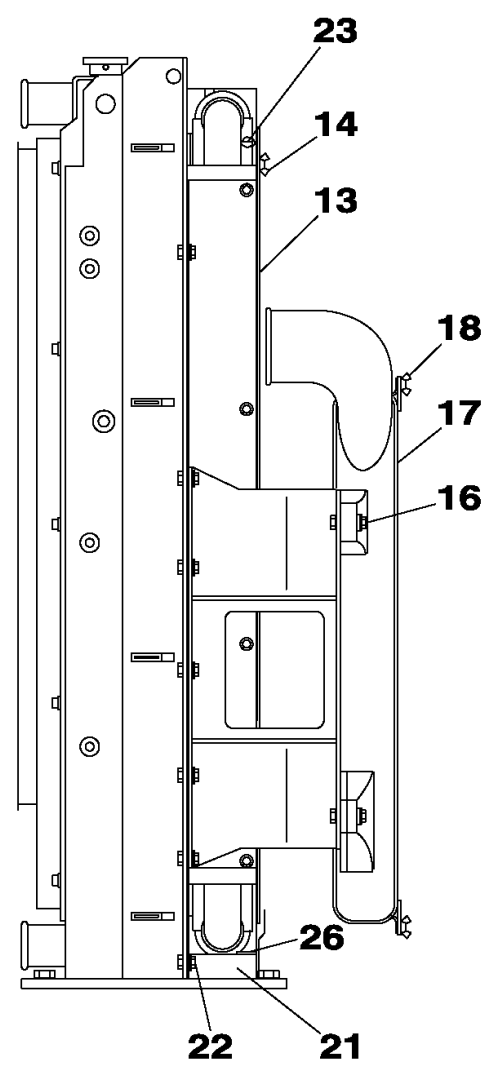
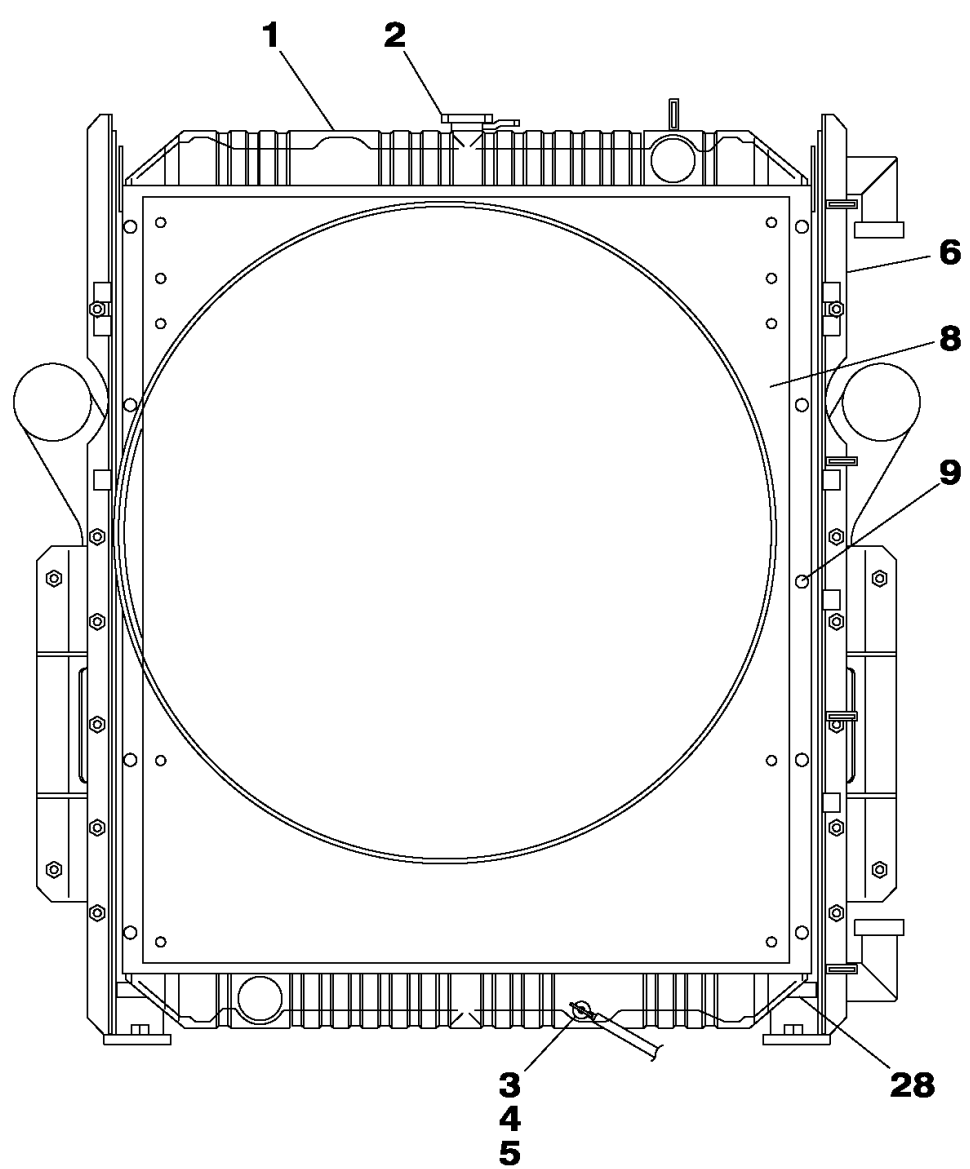
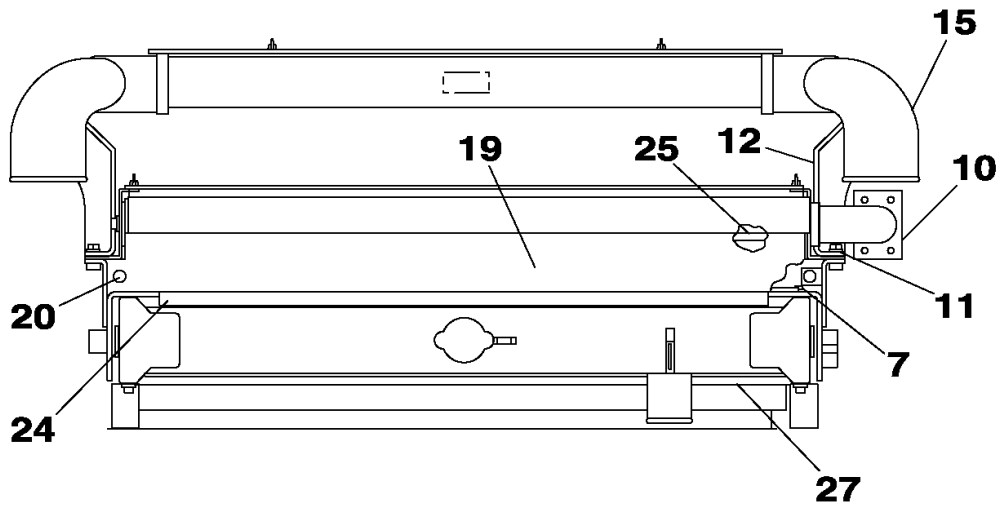

## CX460 CASE CRAWLER EXCAVATOR (EUROPE)

## 02-013-00(01) RADIATOR - OIL COOLER

Ref	Part Number	Qty	Description
	KTH0568	1	RADIATOR, , Consists of Ref Numbers 1To 28
1	LN00099	1	RADIATOR,
2	156601A1	1	PLUG,
3	156602A1	1	COCK,
4	LK00356	1	TUBE, PLASTIC-RUBBER,
5	LA00804	1	CLIP,
6	LT00112	1	FRAME,
7	LA00677	10	BOLT,
8	LW00389	1	SHROUD,
9	LUG0003	8	BOLT,
10	LN00080	1	COOLER, OIL,
11	LA00784	12	BOLT,
12	LS00208	2	BRACKET,
13	LG00405	1	PROTECTOR,
14	156606A1	2	BOLT,
15	LN00100	1	CONDENSER,
16	LUG0033	4	SCREW,
17	LG00444	1	PROTECTOR,
18	156606A1	4	BOLT,
19	LR00807	1	PLATE,
20	LUG0003	2	BOLT,
21	LR00808	1	PLATE,
22	LUG0003	2	BOLT,
23	LE00970	2	FOAM,
24	LE00889	1	FOAM,
25	LE00971	1	FOAM,
26	LE00972	1	FOAM,
27	LE00971	2	FOAM,
28	LE00972	1	FOAM,

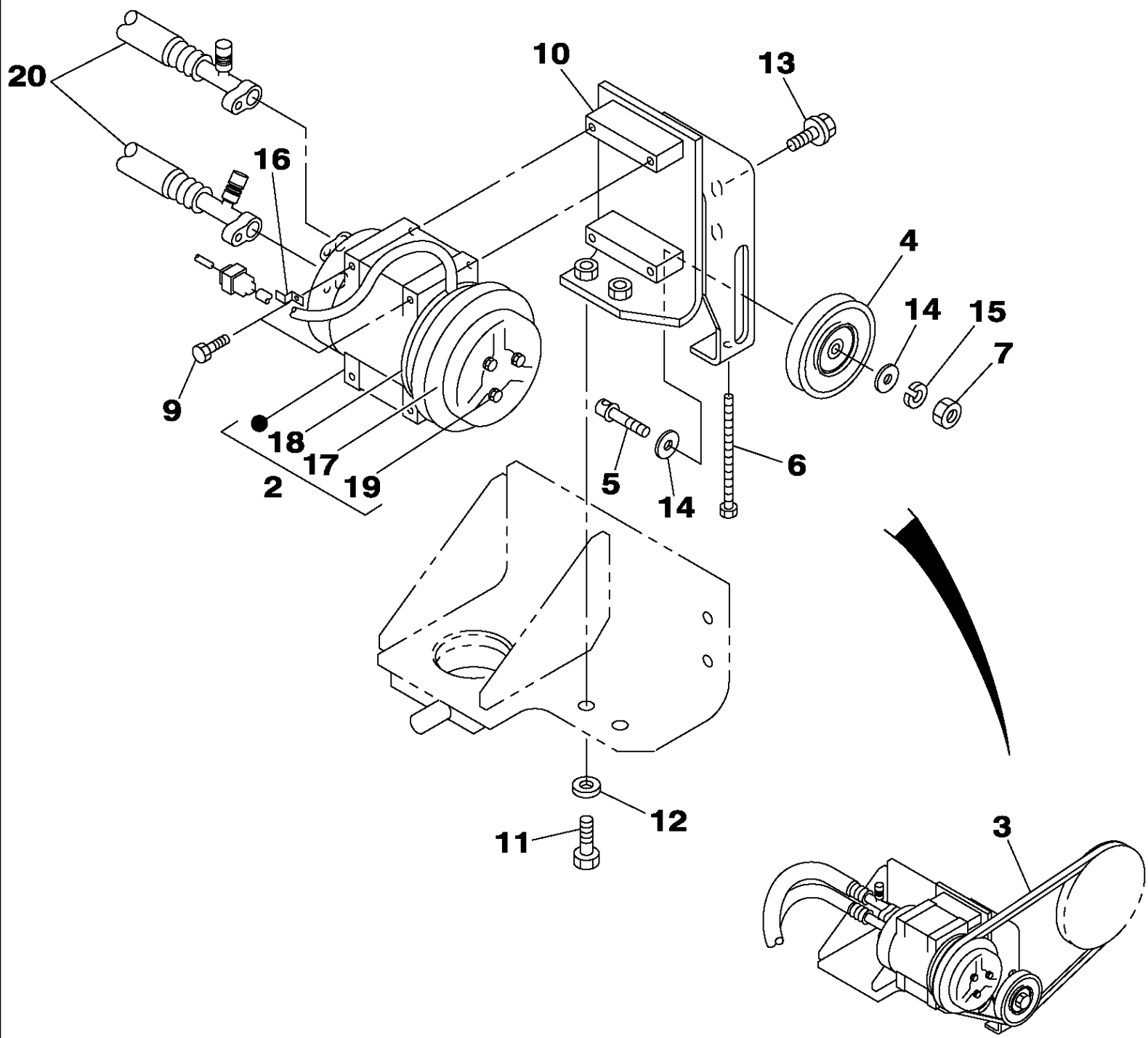

## CX460 CASE CRAWLER EXCAVATOR (EUROPE)

## 02-015-00(01) AIR CONDITIONING - COMPRESSOR MOUNTING

Ref	Part Number	Qty	Description
2	KHR3197	1	COMPRESSOR, , Consists of Ref Numbers 17 To 19
3	KHR3089	1	BELT,
4	157296A1	1	PULLEY,
5	157299A1	1	SHAFT,
6	159644A1	1	BOLT,
7	157292A1	1	NUT, M10
9	KAR0921	4	SCREW,
10	KTR0533	1	BRACKET,
11	627-12040	2	BOLT, Hex, M12 x 40, 10.9, Full Thd, M12 x 40; 10.9
12	150811A1	2	WASHER, M12
13	152718A1	2	BOLT,
14	151977A1	2	WASHER,
15	892-11010	1	WASHER, LOCK, M10, W10
16	158962A1	1	CLIP,
17	KHR3198	1	CLUTCH,
18	KHR3974	1	COVER, PROTECTIVE,
19	KHR3975	3	BOLT,
20	REF	1	INSTRUCTION, Hose,, See Page(s) 09-059

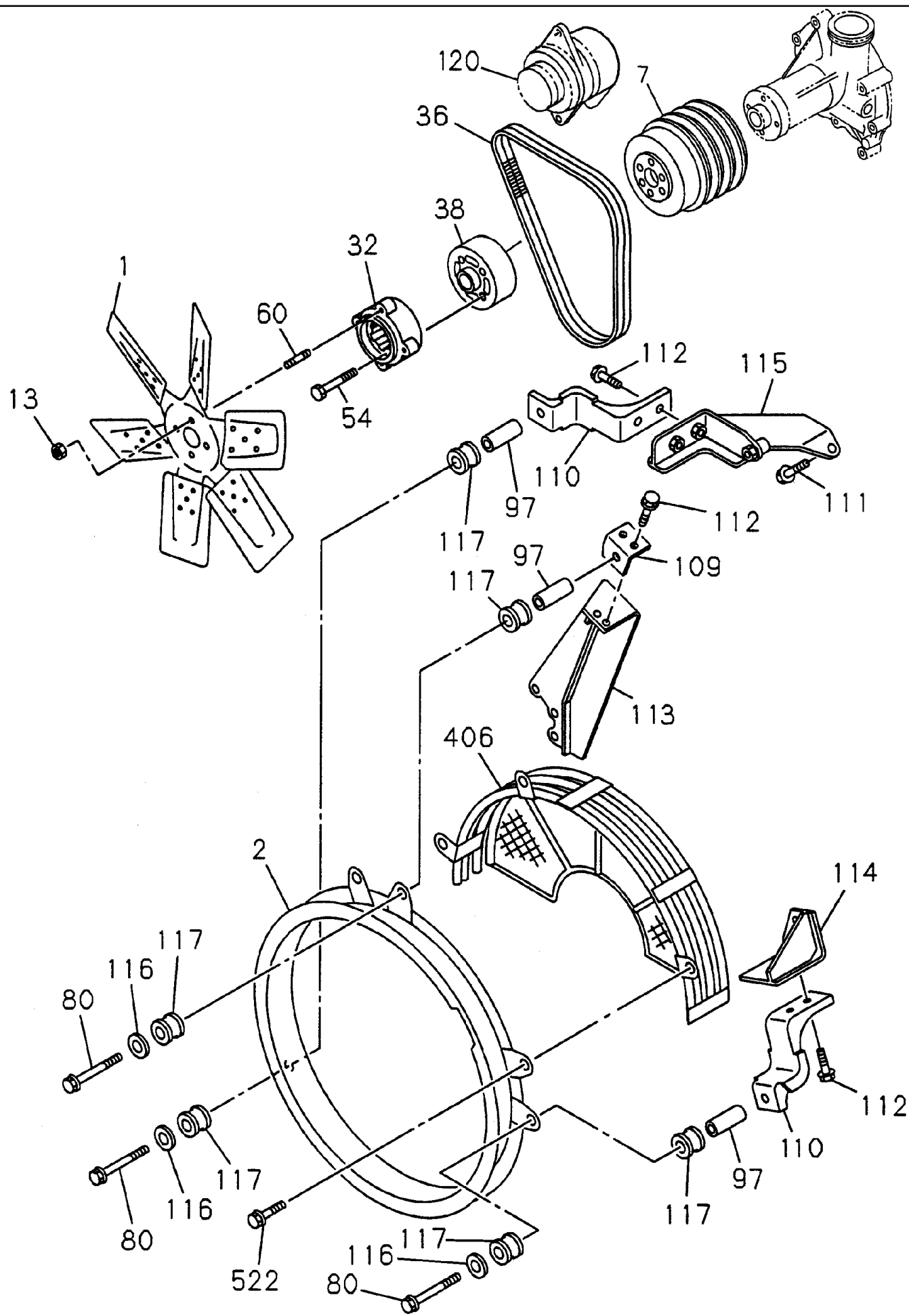



## CX460 CASE CRAWLER EXCAVATOR (EUROPE)

## 02-017-00(01) FAN DRIVE - VENTILATOR

Ref	Part Number	Qty	Description
1	437925A1	1	FAN,
2	86992637	1	GUIDE,
7	86987284	1	PULLEY,
13	426067A1	4	NUT, M10
32	86987285	1	ADAPTER,
36	87454864	1	BELT,
38	437922A1	1	SPACER,
54	86987114	6	BOLT, M10 x 100
60	438181A1	4	STUD, M10 x 45
80	288700A1	3	SCREW,
97	419731A1	3	TUBE,
109	86992639	1	STAY,
110	86992638	2	STAY,
111	419935A1	1	BOLT,
112	288999A1	6	BOLT,
113	86992640	1	BRACKET,
114	86992641	1	BRACKET,
115	86992642	1	BRACKET,
116	419722A1	3	WASHER,
117	419726A1	6	WASHER, RUBBER,
120	438007A1	1	ALTERNATOR, , See Page(s) 04-033
406	437986A1	1	SHIELD,
522	288988A1	3	BOLT,

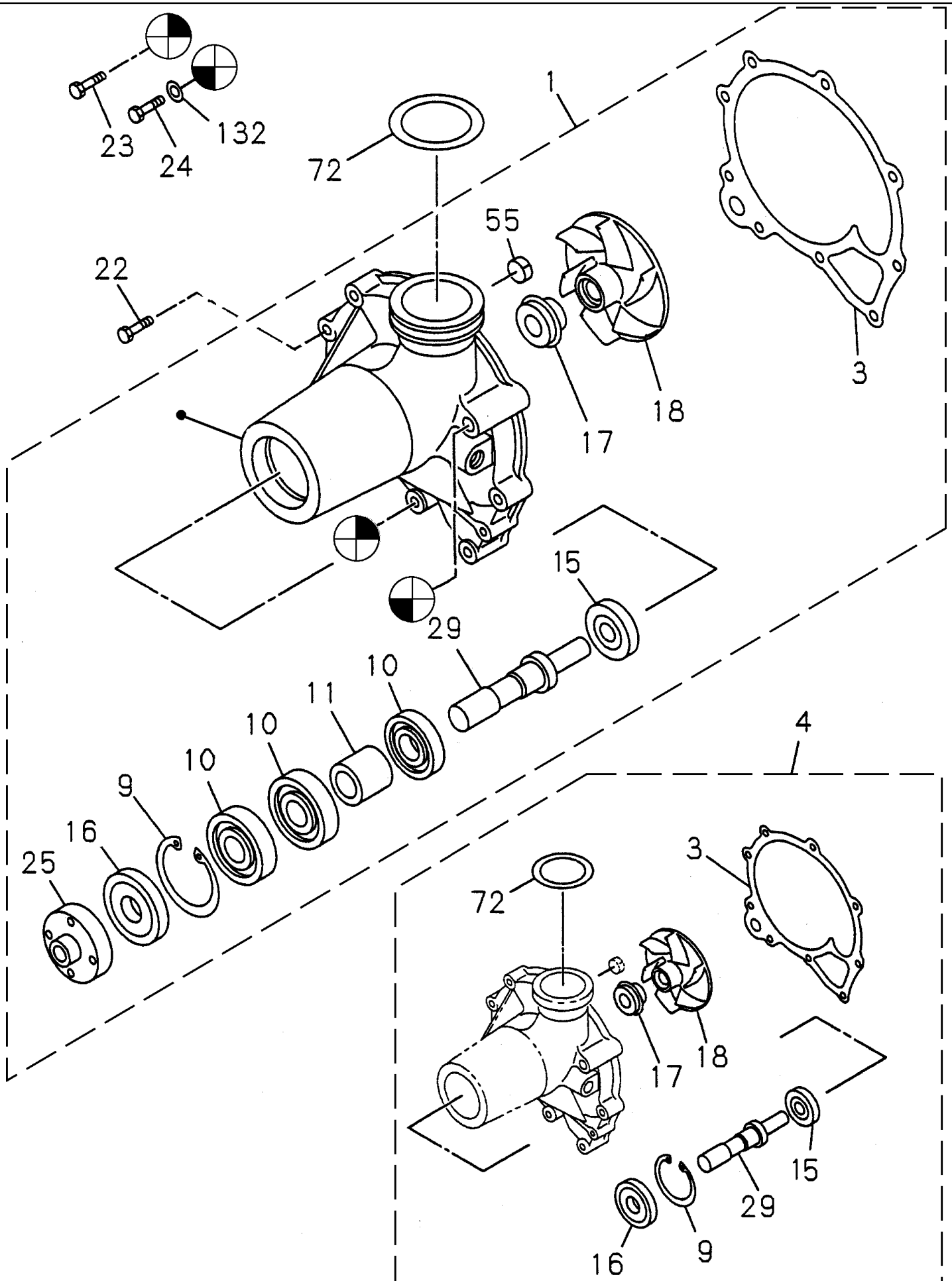

## CX460 CASE CRAWLER EXCAVATOR (EUROPE)

## 02-019-00(01) WATER PUMP

Ref	Part Number	Qty	Description
1	86987091	1	PUMP, WATER, , Consists Of Ref. Numbers 3, 9 To 18, 25 To 55
3	86987279	1	GASKET,
4	86987092	1	KIT, GASKET, , Consists of Ref Numbers 3, 9, 15 To 18, 29, 72
9	438185A1	1	CIRCLIP,
10	86987177	3	BEARING,
11	86987283	1	SPACER,
15	86987165	1	SEAL,
16	86987164	1	SEAL,
17	426098A1	1	SEAL ASSY.,
18	86987281	1	IMPELLER,
22	86987122	1	BOLT, M8 x 35
23	289019A1	6	BOLT, M8 x 45; 10.9
24	86987109	2	BOLT, M10 x 95
25	86987286	1	FLANGE,
29	86987282	1	SHAFT,
55	86987280	1	NOZZLE,
72	86987157	1	GASKET,
132	289788A1	2	WASHER,



## CX460 CASE CRAWLER EXCAVATOR (EUROPE)

## 02-021-00(01) WATER CIRCUIT - THERMOSTAT

Ref	Part Number	Qty	Description
1	86987293	1	THERMOSTAT,
2	86987289	1	HOUSING,
44	86987104	1	BOLT, M8 x 100
44	86987115	3	BOLT, M8 x 140
48	289787A1	4	WASHER, M8
49	86987288	1	PIPE,
50	289035A1	3	BOLT, M8 x 28
64	86987291	1	GASKET,
65	86987292	1	GASKET,
112	355157A1	2	PLUG, M16 x 12
113	426205A1	1	PLUG, M16, PT 3/8

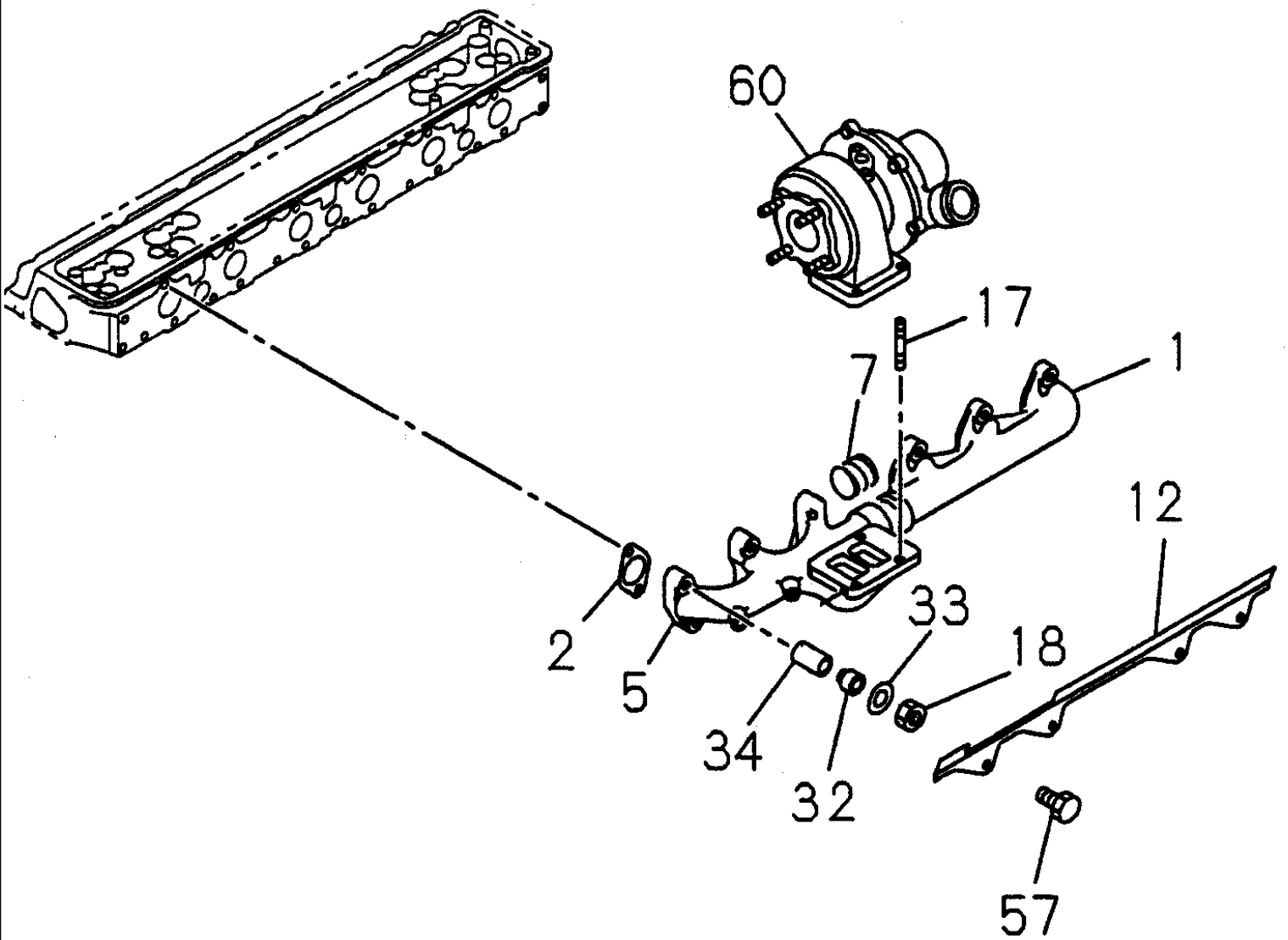

## CX460 CASE CRAWLER EXCAVATOR (EUROPE)

## 02-023-00(01) EXHAUST PIPE - TURBOCHARGER

Ref	Part Number	Qty	Description
1	86987299	1	MANIFOLD, , Replaced By 87410306
1	87410306	1	MANIFOLD,
2	86987301	6	GASKET,
5	86987300	1	MANIFOLD,
7	437934A1	3	GASKET,
12	86987303	1	PROTECTOR,
17	289765A1	4	STUD, M10 x 40
18	289778A1	12	NUT,
32	426069A1	12	WASHER, 5,5 mm
33	426068A1	12	WASHER, 2,2 mm
34	86987302	12	COLLAR,
57	86987118	2	BOLT, M8 x 14
57	86987111	1	BOLT, M8 x 14
57	289014A1	1	BOLT, M8 x 20; 10,9
60	86987068	1	TURBOCHARGER, , See Page(s) 02-027-00-01, 02-029-00-01

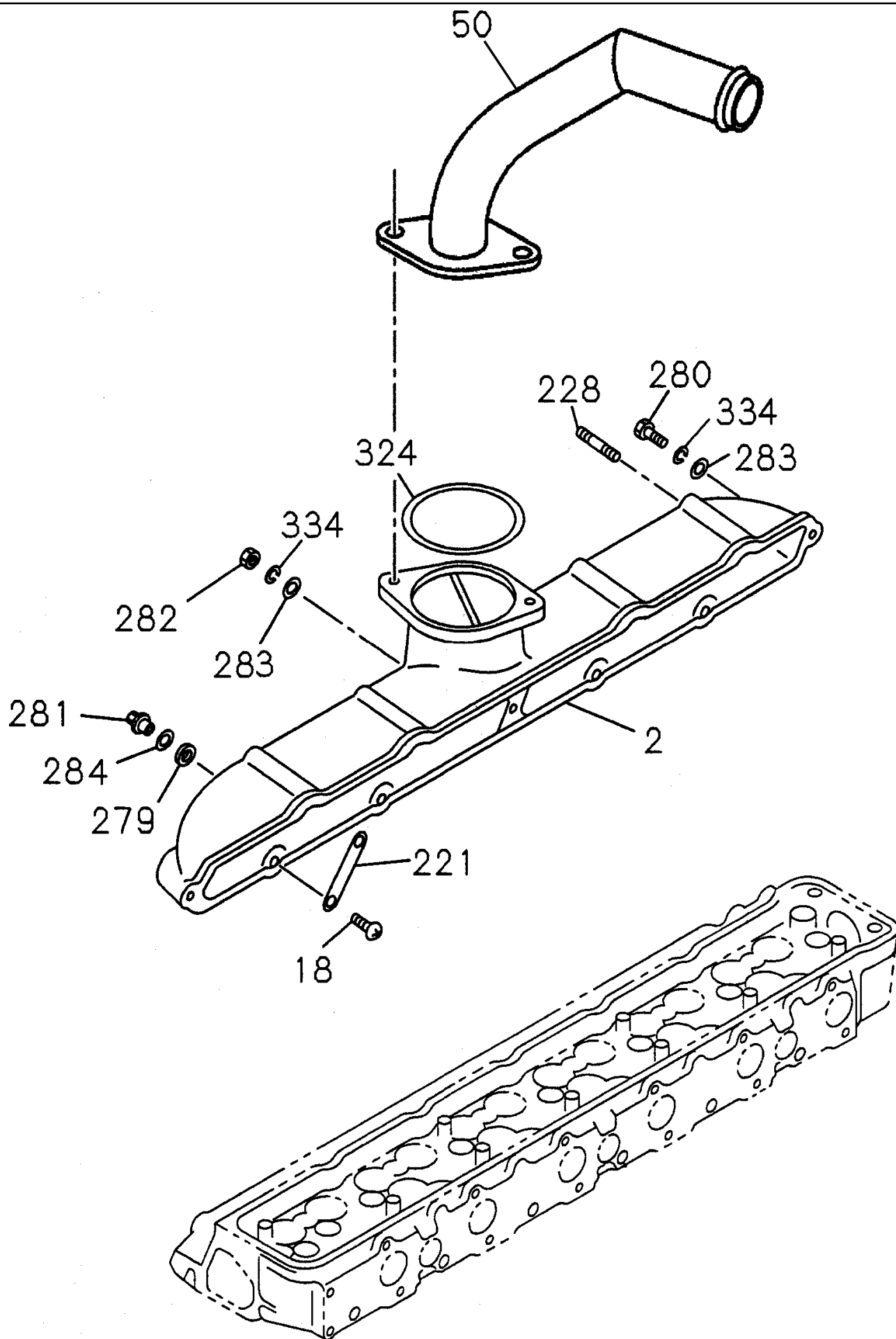



## CX460 CASE CRAWLER EXCAVATOR (EUROPE)

## 02-025-00(01) INTAKE PIPE

Ref	Part Number	Qty	Description
2	86987294	1	COVER,
18	86987131	8	SCREW,
50	86987295	1	PIPE,
221	86987297	4	PLATE,
228	362157A1	1	STUD, M8 x 20
228	353988A1	3	STUD, M8 x 40
279	86987296	4	GASKET,
280	86987411	2	BOLT, M8 x 50
281	86987182	4	NUT,
282	289777A1	1	NUT, M8
283	288851A1	3	WASHER, LOCK, W8
284	86987145	4	WASHER,
324	86987156	1	GASKET,
334	289782A1	3	WASHER, W8

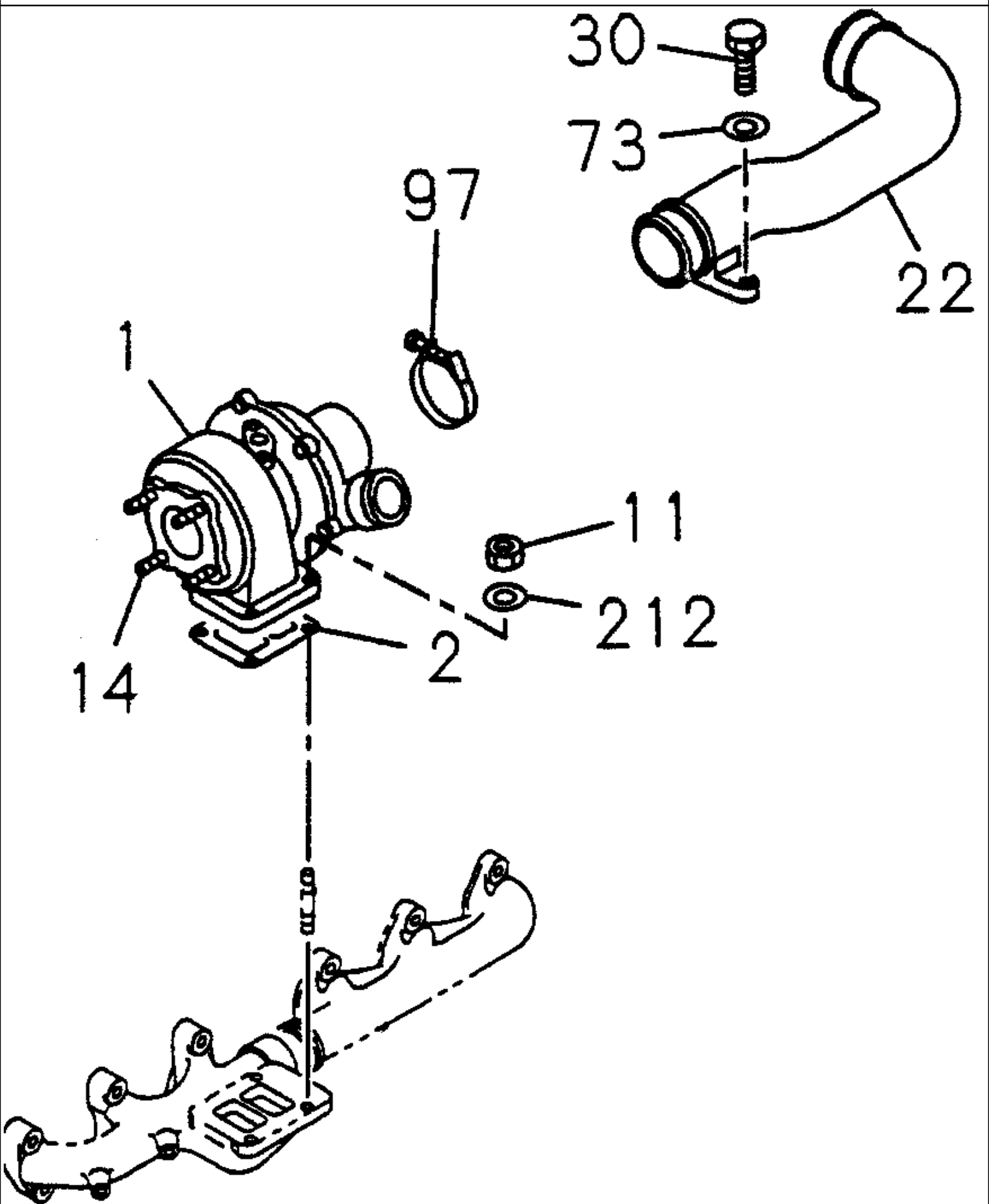

## CX460 CASE CRAWLER EXCAVATOR (EUROPE)

## 02-027-00(01) TURBOCHARGER

Ref	Part Number	Qty	Description
1	86987068	1	TURBOCHARGER, , See Page(s) 02-029
2	289212A1	1	GASKET,
11	289831A1	3	NUT, M10
11	426260A1	1	NUT, M10
14	426261A1	4	STUD, M12 x 135
22	86987298	1	DUCT,
30	355651A1	2	SCREW, M10 x 40; 10,9
73	426507A1	2	WASHER, 10 ID x 2 mm
97	86987174	1	CLAMP,
212	86987119	4	WASHER,

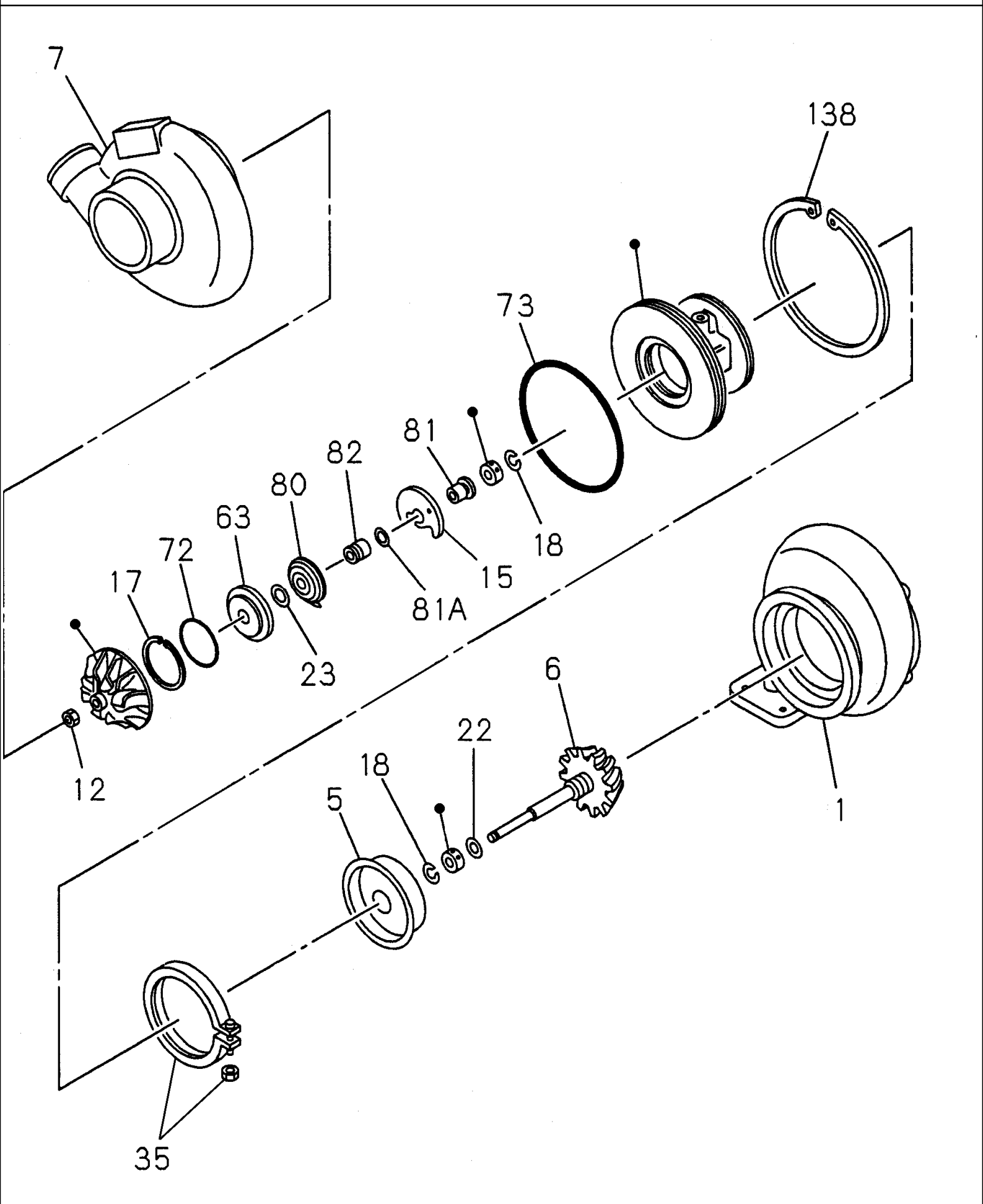

## CX460 CASE CRAWLER EXCAVATOR (EUROPE)

## 02-029-00(01) TURBOCHARGER

Ref	Part Number	Qty	Description
	86987068	1	TURBOCHARGER, , Consists of Ref Numbers 1To 138
1	86987306	1	HOUSING,
5	86987311	1	PROTECTOR,
6	86987313	1	SHAFT,
7	86987306	1	HOUSING,
12	86987315	1	NUT,
15	86987305	1	BEARING,
17	86987308	1	RING,
18	86987320	2	RING,
22	86987321	1	RING,
23	86987317	1	RING,
35	86987304	1	CLAMP,
63	86987312	1	INSERT,
72	86987309	1	GASKET,
73	86987307	1	GASKET,
80	86987310	1	DEFLECTOR,
81A	86987318	1	RING,
81B	86987319	1	RING,
82	86987316	1	SLEEVE,
138	86987314	1	RING,



## CX460 CASE CRAWLER EXCAVATOR (EUROPE)

## 02-031-00(01) FRONT TIMING GEAR COVER

Ref	Part Number	Qty	Description
2	86987190	1	HOUSING,
35	86987162	1	SEAL,
51	289019A1	8	BOLT, M8 x 45; 10.9
51	86987105	2	BOLT, M10 x 50
61	86987413	2	BOLT, M12 x 75
62	437844A1	3	SCREW, M8 x 14
63	86987187	1	COVER,
64	86987152	1	GASKET,
80	289776A1	2	NUT, M10
83	289788A1	4	WASHER,
84	289789A1	2	WASHER,
115	438034A1	1	SENSOR,
175	86987163	1	SEAL,
177	289009A1	1	BOLT,
178	86987106	1	BOLT, M6 x 16
205	288630A1	1	NUT, M12
211	86987413	5	BOLT, M12 x 75
211	437840A1	10	SCREW, M12 x 60
211	86987129	1	BOLT, M12 x 173
211	86987414	2	BOLT, M12 x 90
213	86987191	1	POINTER,
216	419948A1	2	STUD, M8 x 33
218	289791A1	1	WASHER,
222	289775A1	2	NUT, M8
224	86987418	2	STUD, M14 x 61
226	86987449	1	STUD, M12 x 78
229	86987192	1	COVER,
241	86987439	19	WASHER,
242	355158A1	1	GASKET,
268	86987188	1	COVER,
270	86987417	6	STUD, M8 x 20
278	419949A1	1	WASHER,
290	86987193	1	PLUG,
291	355157A1	1	PLUG, M16 x 12

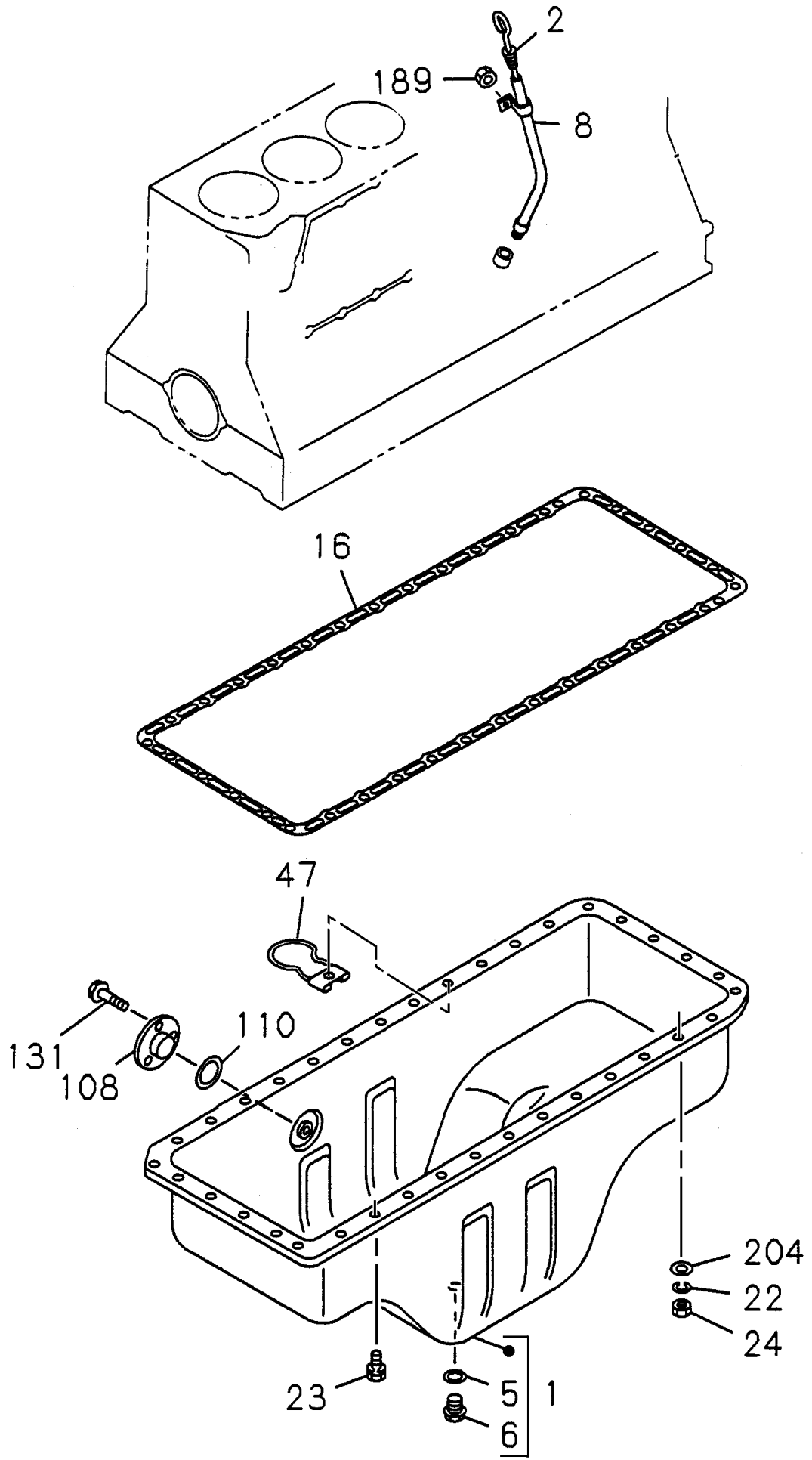



## CX460 CASE CRAWLER EXCAVATOR (EUROPE)

## 02-033-00(01) OIL PAN

Ref	Part Number	Qty	Description
1	86987096	1	PAN, ENGINE OIL, , Consists of Ref Numbers 5, 6
2	87335157	1	GAUGE,
5	86987151	1	GASKET,
6	86987150	1	PLUG,
8	86987204	1	TUBE,
16	86987194	1	GASKET,
22	289782A1	6	WASHER, W8
23	289014A1	30	BOLT, M8 x 20; 10.9
24	289775A1	6	NUT, M8
47	86987239	1	CLIP,
108	86987195	1	COVER,
110	437876A1	1	GASKET,
131	289008A1	3	BOLT,
189	426067A1	1	NUT, M10
204	289787A1	6	WASHER, M8

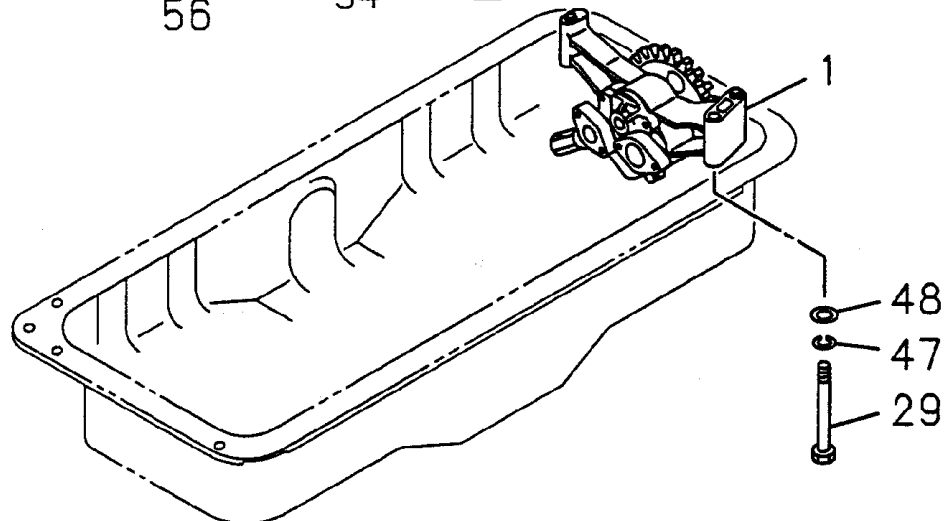
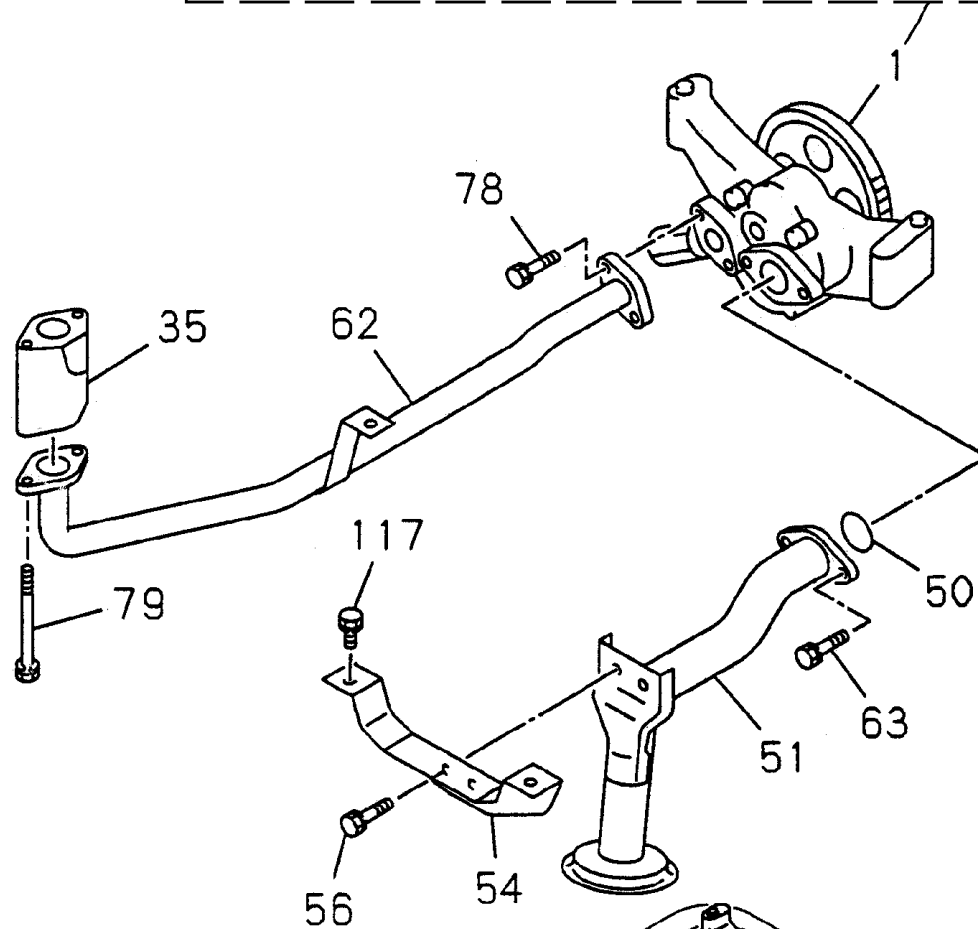
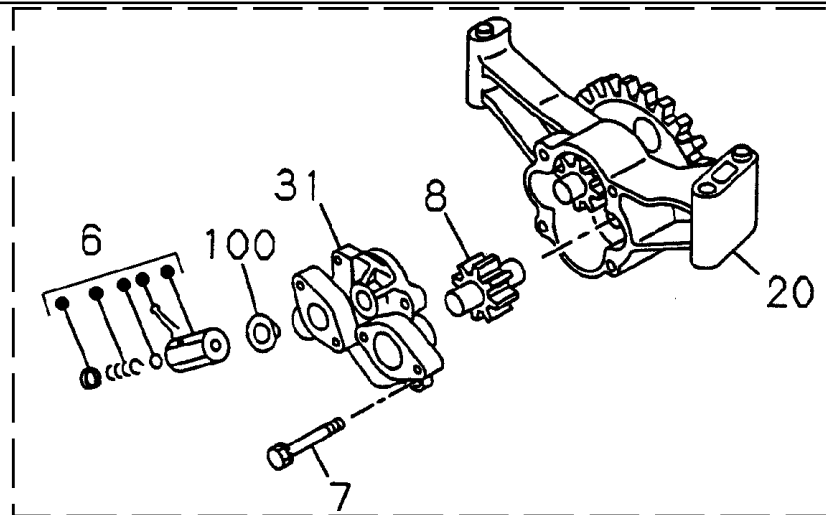

- 48
- 47
- 29

**BUY NOW**

**Then Instant Download  
the Complete Manual  
Thank you very much!**