

CX460 Crawler Excavators

Table of Contents

DIVISION/SECTION	SECTION N°	REFERENCE N°
1 GENERAL INFORMATION		
Safety, general information and standard torque data	1001	7-27690GB
General specifications and special torque setting.....	1002	9-36460GB
2 ENGINE		
Removal and installation of the engine	2000	9-54180GB
Radiator and oil-cooler	2001	9-43480GB
Engine specifications	*	
Disassembly and assembly of the engine.....	*	
3 FUEL SYSTEM		
Fuel tank	3001	9-43470GB
Fuel engine system.....	*	
4 ELECTRICAL SYSTEM		
Electrical system, electrical and electronic troubleshooting	4001	9-40950GB
Inspection and maintenance of batteries and connecting a booster battery	4002	9-43460GB
Main and engine electronic control boxes.....	4003	9-43450GB
5 UNDERCARRIAGE		
Removal and installation of tracks	5001	9-42910GB
Rollers.....	5003	9-44830GB
Sprocket.....	5004	9-36890GB
Idler wheel and tension shock absorber	5005	9-44820GB
6 DRIVE TRAIN		
Drive motor and final drive transmission removal and installation	6001	9-43140GB
Swing reduction gear, removal and installation.....	6003	9-44810GB
Swing reduction gear, disassembly and assembly	6004	9-44590GB
Travel reduction gear assembly and disassembly	6005	9-53710GB
7 UNDERCARRIAGE HYDRAULICS		
8 UPPERSTRUCTURE HYDRAULICS		
Depressurising and decontaminating the hydraulic system, use of the vacuum pump and bleeding the components	8000	9-44560GB
Specifications, troubleshooting, checks and hydraulic pressure settings	8001	9-36910GB
Hydraulic reservoir removal and installation	8002	9-43230GB
Main and pilot pumps, removal and installation	8003	9-53950GB
Main hydraulic control valve, removal and installation.....	8004	9-53990GB
Attachment cylinders, removal and installation.....	8005	9-43250GB
Hydraulic swivel, removal and installation	8006	9-43390GB
Pilot blocs, removal and installation.....	8007	9-53980GB
Swing motor, removal and installation	8008	9-53970GB
Main hydraulic pump, disassembly and assembly.....	8010	9-43330GB
Main hydraulic control valve, disassembly and assembly.....	8011	9-54310GB
Attachment cylinders, disassembly and assembly.....	8012	9-53690GB
Hand control levers, disassembly and assembly	8013	9-54000GB
Foot control levers, disassembly and assembly	8014	7-28210GB
Six-solenoid valves, disassembly and assembly	8015	9-54050GB
Caution valve, disassembly and assembly	8016	7-27942GB
Safety valve	8017	9-54100GB
Hydraulic swivel, disassembly and assembly	8018	9-43190GB
Swing motor, disassembly and assembly	8019	9-54140GB
Hydraulic functions.....	8020	9-42740GB
Travel hydraulic motor, disassembly and assembly.....	8021	9-43160GB

DIVISION/SECTION	SECTION N°	REFERENCE N°
9 UPPERSTRUCTURE		
Upperstructure, turntable and counterweight.....	9002	9-43410GB
Boom, dipper and bucket.....	9003	9-53280GB
Seat and seat belt.....	9004	9-40960GB
Cab and cab equipment.....	9005	9-53410GB
Air conditioning troubleshooting.....	9006	██████████
Air conditioning unit disassembly and assembly.....	9007	██████████
Air conditioning servicing.....	9008	██████████
Air conditioning components.....	9009	██████████
Large format hydraulic and electrical schematics.....	Pocket	9-36070GB

* *Consult the Engine Service Manual*

██████████ *Sections to be distributed at a later date*

NOTE: CNH Company reserves the right to make changes in the specification and design of the machine without prior notice and without incurring any obligation to modify units previously sold.

The description of the models shown in this manual has been made in accordance with the technical specifications known as of the date of design of this document.

Section

1001

**SAFETY, GENERAL INFORMATION
AND STANDARD TORQUE DATA**

TABLE OF CONTENTS

GENERAL INFORMATION	3
SAFETY	4
STANDARD TORQUE DATA FOR CAP SCREWS AND NUTS.....	6

GENERAL INFORMATION

Cleaning

Clean all metal parts except bearings, in a suitable cleaning solvent or by steam cleaning. Do not use caustic soda for steam cleaning. After cleaning, dry and put oil on all parts. Clean oil passages with compressed air. Clean bearings in a suitable cleaning solvent. Dry the bearings completely and put oil on the bearings.

Inspection

Check all parts when the parts are disassembled. Replace all parts that have wear or damage. Small scoring or grooves can be removed with a hone or crocus cloth. Complete a visual inspection for indications of wear, pitting and their replacement of parts necessary to prevent early failures.

Bearings

Check bearings for easy action. If bearings have a loose fit or rough action, replace the bearing. Wash bearings with a suitable cleaning solvent and permit to air dry. **DO NOT DRY BEARINGS WITH COMPRESSED AIR.**

Needle Bearings

Before you press needle bearings in a bore always remove any metal protrusions in the bore or edge of the bore. Before you press bearings into position, put petroleum jelly on the inside and outside diameter of the bearings.

Gears

Check all gears for wear and damage. Replace gears that have wear or damage.

Oil Seals, O-rings and Gaskets

Always install new oil seals, O-rings and gaskets. Put petroleum jelly on seals and O-rings.

Shafts

Check all shafts that have wear or damage. Check the bearing and oil seal surfaces of the shafts for damage.

Service Parts

Always install genuine Case service parts. When ordering refer to the Parts Catalog for the correct part number of the genuine Case replacement items. Failures due to the use of other than genuine Case replacement parts are not covered by warranty.

Lubrication

Only use the oils and lubricants specified in the Operator's or Service Manuals. Failures due to the use of non-specified oils and lubricants are not covered by warranty.

SAFETY



This symbol means ATTENTION! BECOME ALERT! YOUR SAFETY IS INVOLVED. The message that follows the symbol contains important information about safety. Carefully read the message. Make sure you fully understand the causes of possible injury or death.

To prevent injury always follow the Warning, Caution and Danger notes in this section and throughout the manual.

Place a "Do not operate" tag on the starter switch key before carrying out any service or repair work on the machine.



WARNING: *Read the operator's manual to familiarize yourself with the correct control functions.*



WARNING: *Operate the machine and equipment controls from the seat position only. Any other method could result in serious injury.*



WARNING: *This is a one man machine, no riders allowed.*



WARNING: *Before starting engine, study Operator's Manual safety messages. Read all safety signs on machine. Clear the area of other persons. Learn and practice safe use of controls before operating.*

It is your responsibility to understand and follow manufacturers instructions on machine operation, service and to observe pertinent laws and regulations. Operator's and Service Manuals may be obtained from your Case dealer.



WARNING: *If you wear clothing that is too loose or do not use the correct safety equipment for your job, you can be injured. Always wear clothing that will not catch on objects. Extra safety equipment that can be required includes hard hat, safety shoes, ear protection, eye or face protection, heavy gloves and reflector clothing.*



WARNING: *When working in the area of the fan belt with the engine running, avoid loose clothing if possible, and use extreme caution.*



WARNING: *When doing checks and tests on the equipment hydraulics, follow the procedures as they are written. DO NOT change the procedure.*



WARNING: *When putting the hydraulic cylinders on this machine through the necessary cycles to check operation or to remove air from a circuit, make sure all people are out of the way.*



WARNING: Use insulated gloves or mittens when working with hot parts.



WARNING: Lower all attachments to the ground or use stands to safely support the attachments before you do any maintenance or service.



WARNING: Pin sized and smaller streams of hydraulic oil under pressure can penetrate the skin and result in serious infection. If hydraulic oil under pressure does penetrate the skin, seek medical treatment immediately. Maintain all hoses and tubes in good condition. Make sure all connections are tight. Make a replacement of any tube or hose that is damaged or thought to be damaged. **DO NOT** use your hand to check for leaks, use a piece of cardboard or wood.



WARNING: When removing hardened pins such as a pivot pin, or a hardened shaft, use a soft head (brass or bronze) hammer or use a driver made from brass or bronze and a steel head hammer.



WARNING: When using a hammer to remove and install pivot pins or separate parts using compressed air or using a grinder, wear eye protection that completely encloses the eyes (approved goggles or other approved eye protectors).



WARNING: Use suitable floor (service) jacks or chain hoist to raise wheels or tracks off the floor. Always block machine in place with suitable safety stands.



WARNING: When servicing or repairing the machine, keep the shop floor and operator's compartment and steps free of oil, water, grease, tools, etc. Use an oil absorbing material and/or shop cloths as required. Use safe practices at all times.



WARNING: Some components of this machine are very heavy. Use suitable lifting equipment or additional help as instructed in this Service Manual.



WARNING: Engine exhaust fumes can cause death. If it is necessary to start the engine in a closed place, remove the exhaust fumes from the area with an exhaust pipe extension. Open the doors and get outside air into the area.



WARNING: When the battery electrolyte is frozen, the battery can explode if (1), you try to charge the battery, or (2), you try to jump start and run the engine. To prevent the battery electrolyte from freezing, try to keep the battery at full charge. If you do not follow these instructions, you or others in the area can be injured.

STANDARD TORQUE DATA FOR CAP SCREWS AND NUTS

Tightening of Cap Screws and Nuts

Tighten alternately so that tightening torque can be applied evenly. The numbers in the figure below indicate the order of tightening.

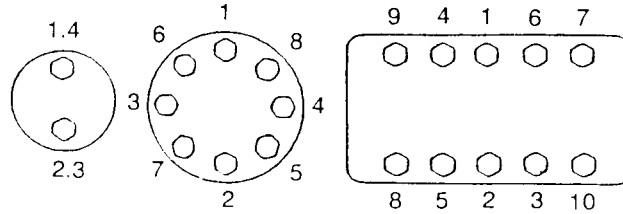

JS00481A

Cap screws which have had Loctite used (white residue remains after removal) should be cleaned with light oil or suitable cleaning solvent and dried. Apply 2-3 drops of Lo ctite to the thread portion of the c ap screw and then tighten.

Torque Table

Tighten cap screws and nuts according to the table below if there are no other special instructions.

Cap Screw Name Size (Size)			M6	M8	M10	M12	M14	M16	M18	M20
Cap Screw	Spanner	[mm]	10	13	17	19	22	24	27	30
		[in.]	0.39	0.51	0.67	0.75	0.87	0.95	1.06	1.18
	Tightening torque	[Nm]	6.9	19.6	39.2	58.8	98.1	157.2	196.0	274.0
		[lb-ft]	5.1	14.5	29.0	43.4	72.5	116.0	144.6	202.4
Socket Head Cap Screw	Spanner	[mm]	5	6	8	10	12	14	14	17
		[in.]	0.20	0.24	0.32	0.39	0.47	0.55	0.55	0.67
	Tightening torque	[Nm]	8.8	21.6	42.1	78.4	117.6	176.4	245.0	343.0
		[lb-ft]	6.5	15.9	31.1	57.8	86.8	130.1	180.8	253.1

Section 1002

1002

SPECIFICATIONS AND SPECIAL TORQUE SETTINGS

TABLE OF CONTENTS

TYPE, SERIAL NUMBER AND YEAR OF MANUFACTURE OF THE MACHINE	3
Machine	3
Engine	3
Serial numbers of the components	3
INGREDIENTS	4
Hydraulic fluid	4
Transmission assembly oil	4
Greases	4
Engine oil	5
Viscosity of oils/Operating range of oils	5
Low fuel	6
Antifreeze/anticorrosive	6
Environment	6
Plastic and resin parts	6
SPECIFICATIONS	7
Engine	7
Capacities	7
Electrical system	7
Hydraulic system	8
Cylinder	8
Control valve	9
Swing	9
Travel	9
Undercarriage	9
Attachment	9
Weight of components	10
DIMENSIONS AND WEAR LIMIT OF THE TRACK ASSEMBLY	11
Sprocket	11
Idler wheel	12
Upper roller	13
Lower roller	14
Track	15
DIMENSIONS AND WEAR LIMITS OF ATTACHMENT LINKAGES	16
Boom foot/Frame	16
Boom cylinder foot/Frame	17
Boom cylinder head/Boom	17
Dipper cylinder foot/Boom	18
Boom/Dipper	18
Dipper cylinder head/Dipper	18
Bucket cylinder foot/Dipper	19
Connecting rod/Dipper	19
Compensator/Bucket	19
Connecting rod/Compensator/Bucket cylinder head	20
Dipper/Bucket	20
SPECIAL TORQUE SETTINGS	21
MACHINE OVERALL DIMENSIONS	24



WARNING: *This symbol is used in this manual to indicate important safety messages. Whenever you see this symbol, carefully read the message which follows. Your safety depends on it.*

TYPE, SERIAL NUMBER AND YEAR OF MANUFACTURE OF THE MACHINE

For all part orders, request for information or assistance, always specify the type and the serial number of the machine to your CASE dealer.

Fill in the following lines with the required information: Type, serial number, year of manufacture of the machine and the serial numbers of the hydraulic and mechanical components.

Machine

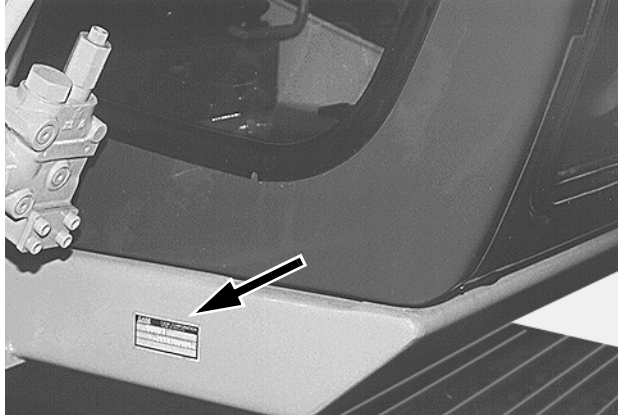

CP98N006

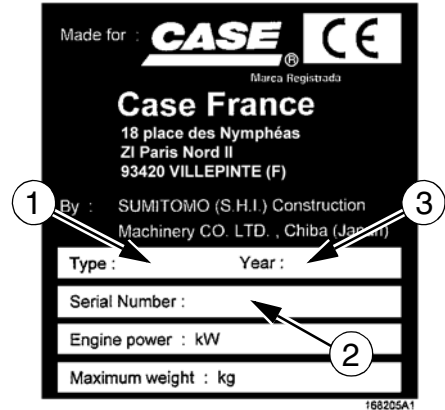

168205A1

CS01J532

- (1) Type
- (2) Serial number
- (3) Year of manufacture

Engine

Make and type

Serial number

Serial numbers of the components

Hydraulic pump

Swing reduction gear

Travel reduction gears

Travel control valve

Attachment control valve

Swing control valve

INGREDIENTS

The ingredients must correspond to specific characteristics for every usage.



WARNING: *You must respect the operating conditions for the different ingredients.*

Hydraulic fluid

The CASE hydraulic fluid is specially adapted for high pressure and CASE's hydraulic circuit. The type of fluid to be used depends on the ambient temperature.

Temperate climates

-20°C to +40°C
Fluid type ISO VG 46
CASE reference: POHYDR

Hot climates

0°C to +60°C
Fluid type ISO VG 100
CASE reference: POHYPC

Cold climates

-40°C to +20°C
Fluid type ISO VG 22
CASE reference: POHYPF

Temperate climate biodegradable fluid:

This yellow-coloured fluid is miscible with standard fluid. When introducing this fluid, it is recommended to drain the hydraulic system completely.

Fluid type: ISO VG 46
CASE reference: CASYNTH 46

These different grades of fluids must comply with the CASE specification.

Transmission assembly oil

Extreme pressure oil used for transmission assemblies in housing.

Extreme pressure oil TYPE API GL5 GRADE 80W90 and ISO VG 150

Greases

The type of grease to be used depends on the ambient temperature.

Hot and temperate climates

-20°C to +60°C
Extreme pressure EP NLGI grade 2 grease with molybdenum disulfide.

Cold climates

-40°C to +20°C
Extreme pressure EP NLGI grade 0 grease.

Engine oil

The CASE No.1 engine oil is recommended for your engine. This oil ensures proper lubrication of your engine for all operating conditions.

If you are unable to procure the CASE No.1 Multiperformance or Performance engine oil, use the corresponding oil from the API/CG/CF category.

NOTE: Do not put any performance additives or any other additives in the engine housing. The oil changing intervals are indicated in this manual based on tests carried out on CASE lubricants.



RD97F136



RD97F100

Viscosity of oils/Operating range of oils

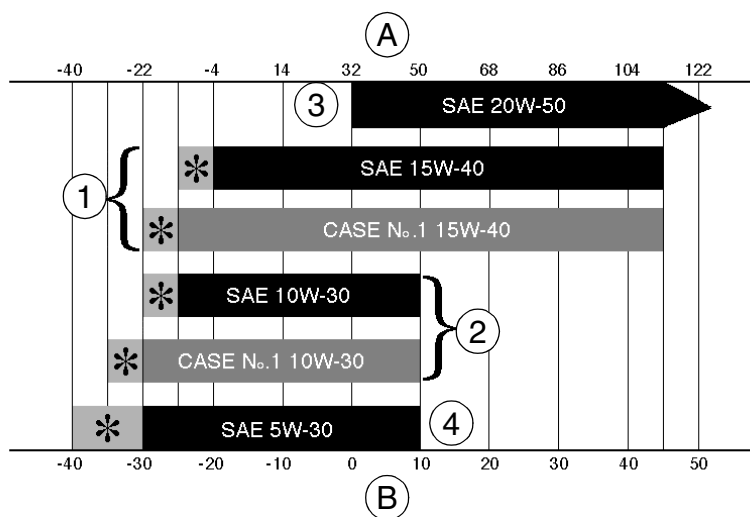

(A) FAHRENHEIT TEMPERATURE

(B) CELSIUS TEMPERATURE

(1) ALL SEASONS

(2) WINTER

(3) TROPICAL

(4) ARCTIC

(*) SHOWS THAT IT IS NECESSARY TO USE AN ENGINE OIL HEATER OR THERMAL COOLER.

CS98M561

Low fuel

The fuel to be used must comply with the D975 norm of the American Society for Testing and Materials (ASTM).

Use type No.2 fuel, use of other fuels can cause a loss of engine power and excessive fuel consumption.

In cold weather, it is provisionally accepted that a mixture of No.1 and No.2 fuels be used. Contact your fuel supplier.

If the temperature drops below the freezing point of the fuel (point where paraffin appears), paraffin crystals in the fuel will cause loss of engine power or starting trouble.

IMPORTANT: *In cold weather, fill up the reservoir with fuel after each workday, in order to avoid the formation of condensation.*

Storing fuel

Prolonged storage of fuel promotes the accumulation of foreign bodies or condensed moisture in the storage tank. Many engine failures are caused by the presence of water in fuel.

The storage tank must be placed outside and the fuel should be maintained at as low a temperature as possible. Drain the condensed moisture at regular intervals.

Antifreeze/anticorrosive

Use the antifreeze in all seasons to protect the coolant system from corrosion and to avoid any risk of freezing.

In environments with a temperature greater than -36°C, use a 50% mixture of antifreeze in an ethylene glycol base.

In environments with a temperature less than -36°C, it is recommended that you use a 40% water and 60% antifreeze mixture.

Environment

Before carrying out any maintenance operation on this machine and before throwing away the liquids or lubricants used, always think of the environment. Never throw oil or liquids on the ground and never put them in leaking containers.

Consult your local centre for ecological recycling for information on the appropriate method for disposing off these substances.

Plastic and resin parts

When cleaning plastic parts, on the console, the instrument panel, the indicator and gauges etc., do not use petrol, paraffin, paint solvents, etc. Use only water, soap and a soft cloth.

The use of petrol, paraffin, paint solvents, etc. causes discoloration, cracks or deformation of these parts.

SPECIFICATIONS

CX460

Engine

Make	Isuzu
Model	6SD1XQB
Type: Four stroke, water cooled with overhead valves, direct injection in-line cylinder (electronic control) with turbo-charger.	
Number of cylinders	6
Bore and stroke	120 x 145 mm
Displacement	9839 cm ³
Operating conditions	
Idle	900 rpm
Max speed	1950 rpm
Power ECC 1289	250.1 kW (335.4 HP)
Max torque	1344 Nm at 1600 rpm

Capacities

Engine oil capacity	33 litres
Engine cooling circuit	45.5 litres
Capacity of only the radiator	21 litres
Fuel reservoir	611 litres
Hydraulic fluid reservoir capacity	220 litres
Total hydraulic circuit capacity	450 litres
Capacity of only the oil-cooler	16.5 litres
Travel reduction gear housing capacity	15 litres
Swing drive housing capacity	10.5 litres
Idler pulley capacity	260 cm ³
Upper roller capacity	245 to 250 cm ³
Lower roller capacity	280 cm ³

NOTE: *These capacities are given only for information purposes. To check the fluid levels, always use the oil gauge, visual gauges or the filler cap.*

Electrical system

Type of system	24 volts earth negative
Alternator amperage	50 amperes
Battery	
Number of batteries required	2
Voltage of each battery	12 volts
Capacity	140 Ah
Reserve	160 min
Cold startability at -17°	800 A
Load for load control	400 A
Starter	
Voltage	24 volts
Power	5.5 kW
Voltage regulator	built-in, without adjustment

Hydraulic system

Main hydraulic pump

Variable flow dual pump, with axial pistons.

Maximum flow.....	2 x 360 l/min
Displacement.....	2 x 182 cm ³

Hydraulic pilot pump

Fixed flow pump

Max flow	30 l/min
Displacement.....	15 cm ³

Pressure setting

Pilot circuit relief	39 ± 1 bar
Main circuit relief (standard)	314 ± 3 bar
Main circuit relief (power-up)	343 ± 5 bar
Secondary relief (boom raising, dipper and bucket)	363 ± 5 bar
Secondary reliefs (boom lowering)	245 ± 5 bar
Secondary reliefs (swing)	294 ± 5 bar
Secondary relief (travel)	380 ± 5 bar
Safety valve (boom and dipper)	363 ± 5 bar

Cylinder

Boom cylinder

Cylinder bore	170 mm
Rod diameter	115 mm
Stroke	1550 mm

Dipper cylinder

Cylinder bore	200 mm
Rod diameter	140 mm
Stroke	1820 mm

Bucket cylinder

Cylinder bore	165 mm
Rod diameter	115 mm
Stroke	1285 mm

Cylinder leakage - attachment lowering (without load)

Boom cylinders (rods retracted)	3 mm/5 min
Dipper cylinder (rod extended)	3 mm/5 min
Dipper cylinder (rod extended)	7 mm/5 min
Total (at the end of the attachment)	200 mm/10 min

Cylinder speed (in S mode)

Boom raised (bucket open and on the ground)	4.9 s
Boom lowering (bucket open)	3.6 s
Dipper extend	3.8 s
Dipper retract.....	4.7 s
Bucket open.....	3.4 s
Bucket close	5.6 s

Control valve

Five-element control valve for dipper, boom acceleration, swing, option and right travel.

Four-element control valve for dipper, bucket, boom acceleration and left travel.

Load holding relief valve for boom and dipper.

CX460

Swing

Fixed flow engine with axial pistons.

Automatic disk brakes.

Upperstructure frame swing speed.....	9.0 rpm
Displacement.....	250 cm ³
Work flow.....	360 l/min
Reduction ratio.....	27.143
Brake torque.....	Š 1287 Nm
Minimum brake release pressure.....	29 bar
Permissible motor leak.....	18 l/min

Travel

Two-speed motor with axial pistons.

Automatic disk brakes.

Low speed.....	3.1 kph
High speed.....	5.3 kph
Gradeability.....	70% (35°)
Tractive effort.....	35 600 daN
Displacement.....	290.7/170.1 cm ³
Work flow.....	360.4 l/min
Reduction ratio.....	60.652
Braking torque (reduction gear excluded).....	Š 902 Nm
Number of sprocket turns (10 turns)	
Mode "S", high speed.....	18.2 s
Mode "S", low speed.....	30.5 s
Permissible deviation in travel over a distance of 20 m	
Mode "H", full speed.....	1 m
Permissible motor leak.....	14 l/min

Undercarriage

One-piece frame with fabricated elements.

Lubricated rollers and idler wheels.

Grease track tension.

Weight load on track

with 600 mm track pads.....	0.81 bar
with 750 mm track pads.....	0.66 bar
with 900 mm track pads.....	0.56 bar
Track tension.....	360 to 380 mm

Attachment

Break-out force.....	27 000 daN
Break-out force	
2.50 m dipper.....	28 100 daN
3.40 m dipper.....	22 900 daN

Weight of components

Engine	700 kg
Hydraulic pump.....	210 kg
Attachment control valve	426 kg
Swing motor and reduction gear assembly	534 kg
Travel motor and reduction gear assembly	600 kg
Boom cylinder.....	xxx kg
Dipper cylinder.....	xxx kg
Bucket cylinder	xxx kg
Counterweight	9180 kg
Cab	254 kg
Turntable.....	710 kg
Upperstructure assembly.....	18 260 kg
Hydraulic swivel.....	54 kg
Frame assembly	17 750 kg
Machine without attachment.....	36 710 kg
Attachment	10 230 kg
Boom assembly.....	4810 kg
Dipper assembly.....	3040 kg
Radiator and oil-cooler assembly	170 kg
Fuel reservoir.....	242 kg
Hydraulic reservoir.....	220 kg
Idler wheel	235 kg
Upper roller.....	45 kg
Lower roller.....	80 kg
Tension damper.....	359 kg
600 mm track.....	2590 kg
750 mm track.....	2935 kg
800 mm track.....	3050 kg
900 mm track.....	3285 kg

DIMENSIONS AND WEAR LIMIT OF THE TRACK ASSEMBLY

Sprocket

Dimensions

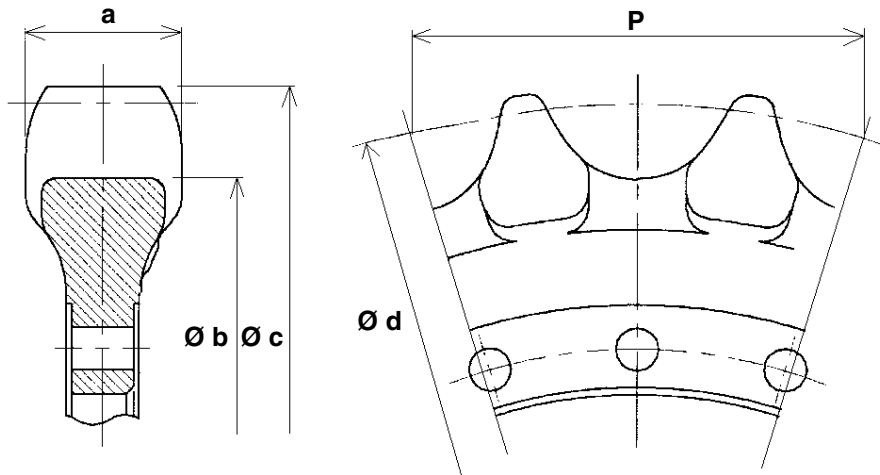

CS01B512

Mark		Dimension (mm)
a	Standard	90
	Limit	78
Ø b	Standard	773.6
	Limit	761.6
Ø c	Standard	867.5
	Limit	854.5
Ø d	Standard	847.3
	Limit	---
P	Standard	229
	Limit	---

Gauge

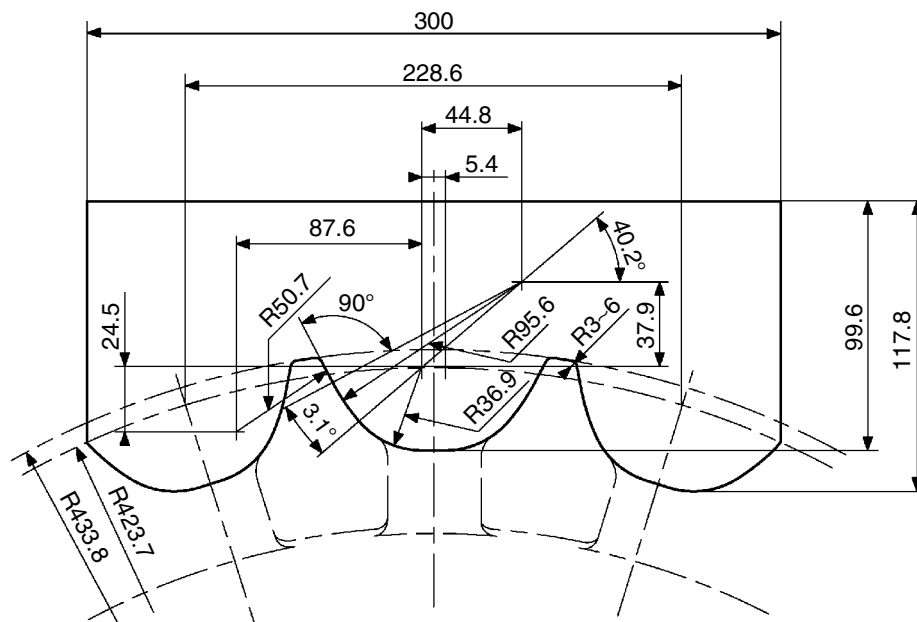

Idler wheel

Dimensions

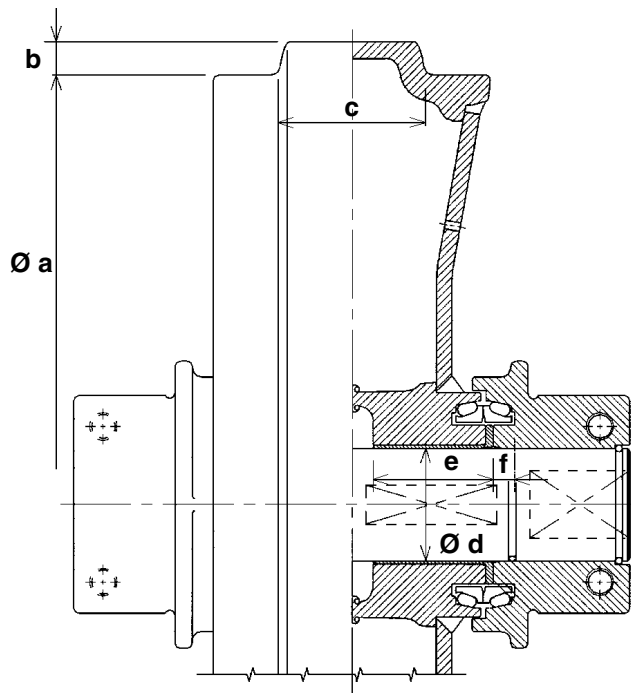

Mark		Dimension (mm)
$\varnothing a$	Standard	676
	Limit	665
b	Standard	22.5
	Limit	---
c	Standard	102
	Limit	92
$\varnothing d$ (shaft)	Standard	95
	Limit	94
$\varnothing d$ (bushing)	Standard	95
	Limit	96
e	Standard	100
	Limit	99
f	Standard	15
	Limit	---

CS01B514

Gauge

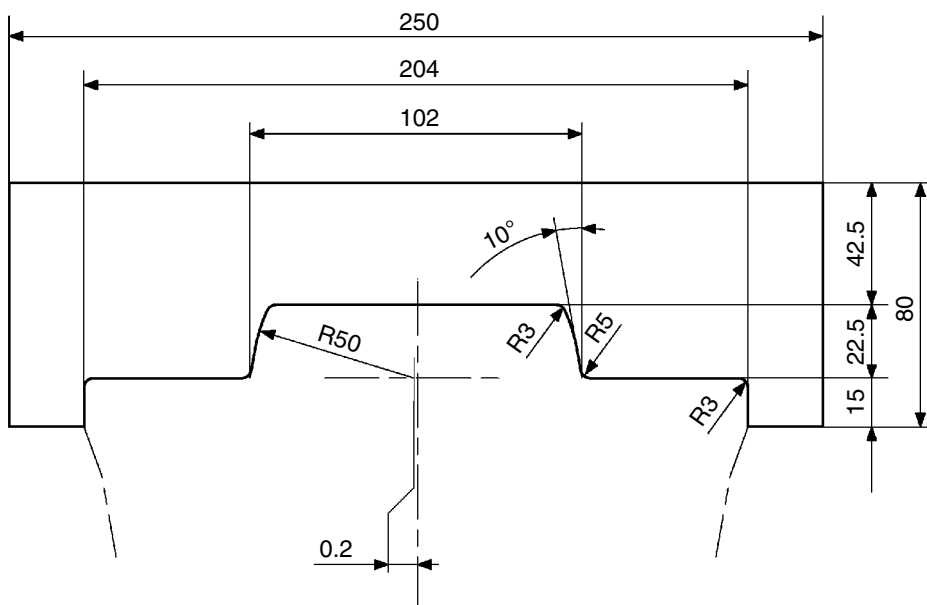

C101N502

Upper roller

Dimensions

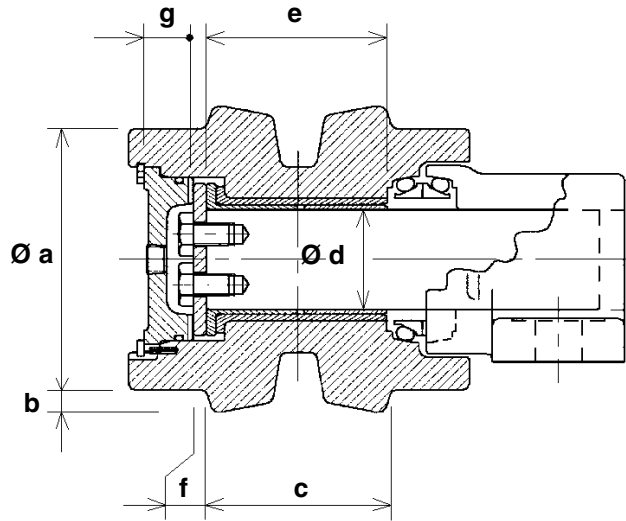

CS01B516

Mark		Dimension (mm)
$\varnothing a$	Standard	150
	Limit	140
b	Standard	15
	Limit	---
c	Standard	104
	Limit	---
$\varnothing d$ (shaft)	Standard	65
	Limit	64
$\varnothing d$ (bushing)	Standard	65
	Limit	66
e	Standard	69
	Limit	68
f	Standard	9
	Limit	8.5
g	Standard	30
	Limit	---

Gauge

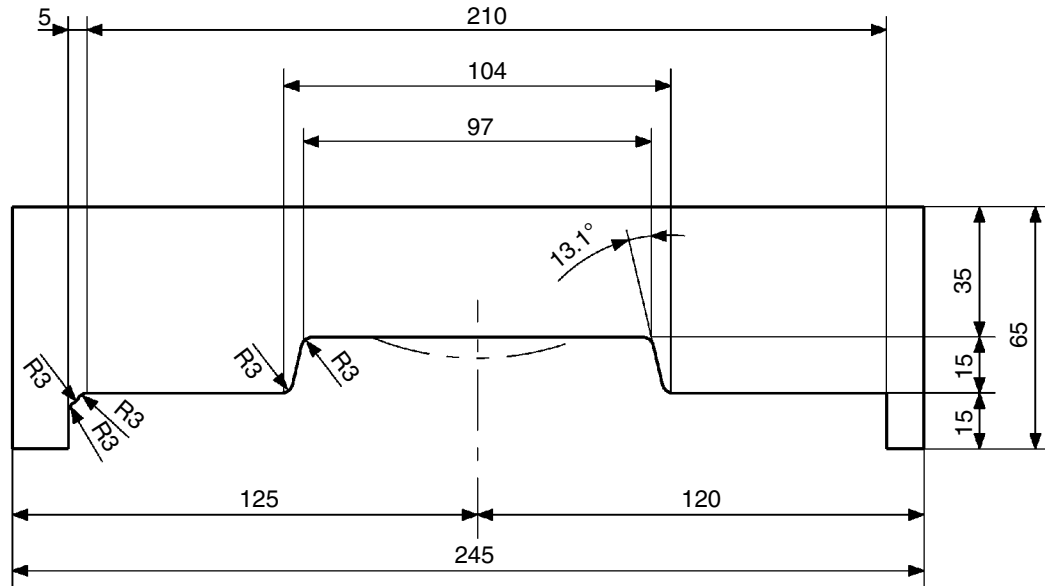

CI01N503

BUY NOW

**Then Instant Download
the Complete Manual
Thank you very much!**