

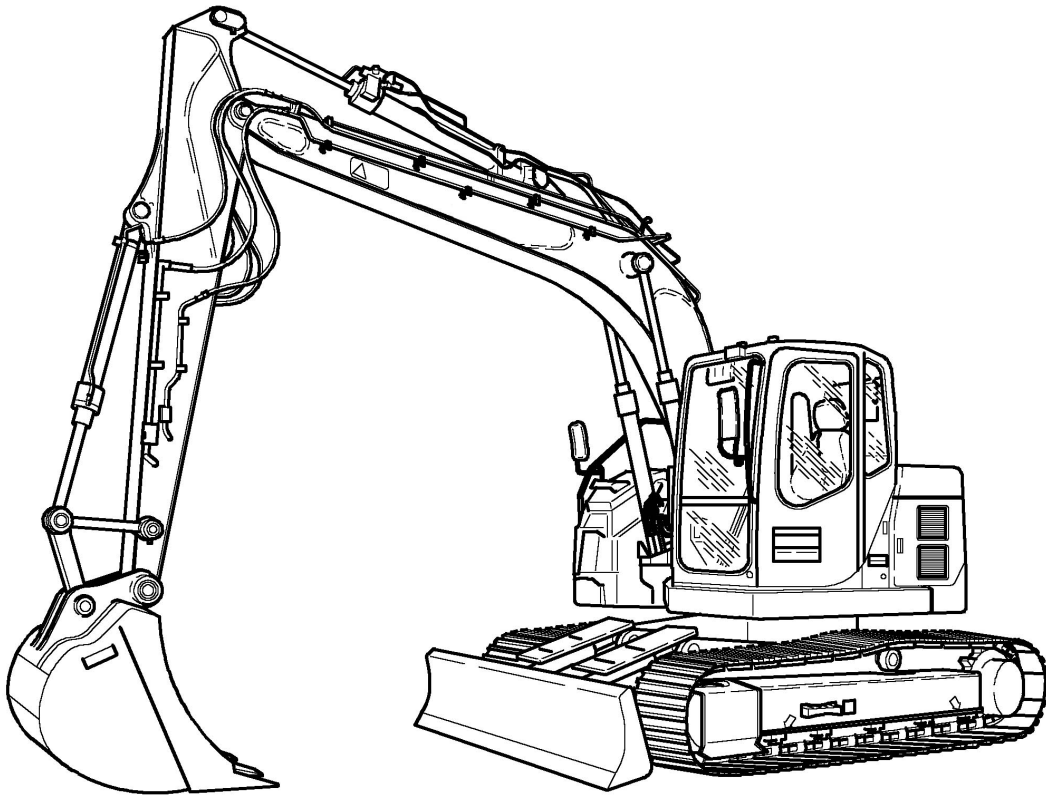

REPAIR MANUAL



CX75SR
CX80

Contents

INTRODUCTION
DISTRIBUTION SYSTEMS
POWER PRODUCTION
TRAVELLING
BODY AND STRUCTURE
FRAME POSITIONING
WORKING ARM
TOOLS AND COUPLERS

A
B
D
E
F
H
J



INTRODUCTION

Contents

INTRODUCTION

Foreword (- A.10.A.40) CX75SR, CX80	3
Safety rules (- A.50.A.10) CX75SR, CX80	4
Basic instructions (- A.90.A.05) CX75SR, CX80	6
Torque (- A.90.A.10) CX75SR	7
Torque (- A.90.A.10) CX80	10
Dimension (- A.92.A.30) CX75SR	13
Dimension (- A.92.A.30) CX80	15
Weight (- A.92.A.40) CX75SR	17
Weight (- A.92.A.40) CX80	18
Consumables (- A.92.A.55) CX75SR, CX80	19
Hydraulic contamination (- A.92.A.60) CX75SR, CX80	22
Product identification (- A.80.A.10) CX75SR WE, CX80 WE	24
Product identification (- A.80.A.10) CX75SR NA, CX80 NA	25

Foreword (- A.10.A.40)

CX75SR, CX80

INTRODUCTION TO THE REPAIR MANUAL

This manual has been designed so that in the near future it can be made available on CD and in a database via a computer network.

This will allow fast and targeted search and navigation between the various information modules.

Information search

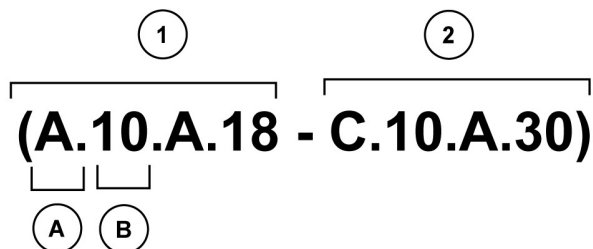

CRIL03J033E01 1

This manual is organised according to types of function and information.

- The function and information types are codified and appear in parentheses after the title and separated by a dash:
 - (1) Function
 - (2) Information type.
- Only the first letter (**A**) and the first number (**B**) of the function need to be used for the information search.
 - The first letter (**A**) corresponds to the sections of the repair manual.
 - The first number (**B**) corresponds to the chapters of the repair manual.
 - The first part of the (**A.B**) code is reflected in the page numbering.
 - THE REST OF THE CODING IS NOT LISTED IN ALPHA-NUMERIC ORDER IN THIS MANUAL.
- You will find a table of contents at the beginning and end of each section and chapter. You will find an alphabetical index at the end of each chapter.
- Therefore it is the first part of the (**A.B**) coding, then the tables of contents and index (page numbers) which will allow you to quickly find the information you are looking for.

Safety rules (- A.50.A.10)

CX75SR, CX80

**CAUTION**

M171C - THIS SAFETY ALERT SYMBOL INDICATES IMPORTANT SAFETY MESSAGES IN THIS MANUAL. WHEN YOU SEE THIS SYMBOL, CAREFULLY READ THE MESSAGE THAT FOLLOWS AND BE ALERT TO THE POSSIBILITY OF DEATH OR SERIOUS INJURY.

ATTENTION: To avoid injury, always observe the Safety Notices, CAUTION and ATTENTION, contained in this section and throughout the manual.

Place a "Do not start the machine" warning notice on the starter switch key before all maintenance or repair operations.

**CAUTION**

M489 - Read the operators manual to familiarize yourself with the correct control functions.

**CAUTION**

M490 - Operate the machine and equipment controls from the seat position only. Any other method could result in serious injury.

**CAUTION**

M265A - A frequent cause of personal injury or death is persons falling off and being run over. Do not permit anyone to ride on the machine.

**CAUTION**

SB055 - Before starting engine, study operators manual safety messages. Read all safety signs on machine. Clear the area of other persons. Learn and practice safe use of controls before operation. It is your responsibility to understand and follow manufacturers instructions on machine operation, service, and to observe pertinent laws and regulation. Operators and service manuals can be obtained from your dealer.

ATTENTION: You risk injury if you wear loose clothing or if you do not use safety equipment for your work. Always wear clothes which are unlikely to become caught in the machinery. Other safety equipment may be required, in particular: hard hat, safety boots, ear protectors, safety goggles or mask, thick gloves and reflective clothing.

**CAUTION**

M124A - Rotating machine parts, stay clear, keep shields installed to help protect from clothing entanglement and injury. Wear close-fitted clothing.

**CAUTION**

SB071 - Rotating fan and belts: Contact will cause injury. Keep clear.

ATTENTION: Follow the procedures exactly when carrying out checks or inspections on the vehicle's hydraulic systems. DO NOT CHANGE the procedures.

ATTENTION: Before running the hydraulic cylinders in this vehicle through the cycles necessary for checking their functioning or for draining a circuit, warn people nearby to move away.

**CAUTION**

SM121A - Always wear heat protective gloves to prevent burning your hands when handling heated parts.

**CAUTION**

M132B - Lower or block elevated implements and other attachments before servicing or when leaving the equipment.

**CAUTION**

R149C - Hydraulic oil or diesel fuel leaking under pressure can penetrate the skin and cause infection or other injury. To Prevent Personal Injury: Relieve all pressure, before disconnecting fluid lines or performing work on the hydraulic system. Before applying pressure, make sure all connections are tight and components are in good condition. Never use your hand to check for suspected leaks under pressure. Use a piece of cardboard or wood for this purpose. If injured by leaking fluid, see your doctor immediately.

ATTENTION: *To remove a hardened pin, such as a pivot pin, or a hardened shaft, use a soft-headed hammer (brass or bronze) or a brass or bronze peg and a steel-headed hammer.*

**CAUTION**

M428 - Always wear safety glasses when using a drill, hammer, saw, or other tools that may cause chips to fly.

ATTENTION: *Use suitable servicing jacks or a chain hoist for raising the wheels or tracks. Always chock the vehicle in place with suitable safety supports.*

ATTENTION: *When carrying out maintenance or repair operations on the vehicle, keep the workshop floor, the driving position and the steps free from oil, water, grease, tools, etc... Use an oil absorbent material and/or workshop cloths as necessary. Always use sound methods.*

ATTENTION: *Some parts of this vehicle are very heavy. Use lifting devices or additional assistance recommended in the Operator's Manual.*

**CAUTION**

M532 - Do not operate the engine in a closed building. Proper ventilation is required under all circumstances.

**CAUTION**

M503 - When the battery electrolyte is frozen, the battery can explode if (1), you try to charge the battery, or (2), you try to jump start and run the engine. To prevent the battery electrolyte from freezing, try to keep the battery at full charge. If you do not follow these instructions, you or others in the area can be injured.

**CAUTION**

M244A - BATTERIES CONTAIN ACID AND EXPLOSIVE GAS. EXPLOSION CAN RESULT FROM SPARKS, FLAMES, OR WRONG CABLE CONNECTIONS. TO CONNECT JUMPER CABLES OR CHARGER, SEE MANUAL(S) FOR THE CORRECT PROCEDURE. FAILURE TO FOLLOW THE ABOVE INSTRUCTIONS CAN CAUSE SERIOUS PERSONAL INJURY OR DEATH.

Basic instructions (- A.90.A.05)

CX75SR, CX80

GENERAL

Cleaning

Clean all metal parts except the bearings with white spirit or steam. Do not use caustic soda for steam cleaning. After each cleaning, dry and oil all parts. Clean the oil ducts with compressed air. Clean the bearings with paraffin, then dry them completely and lubricate them.

Inspection

Check all the parts when they are disassembled. Replace all parts that show signs of wear or damage. Superficial scratches and grooves can be removed with an oil stone or with a cloth dipped in red oxide. A complete visual inspection is necessary to detect wear and pitting, and replacing parts as soon as it becomes necessary will help to avoid premature breakdowns.

Bearings

Check that the bearings turn freely. Replace them if their adjustment is too free or if their functioning is irregular. Wash the bearings with a good solvent or paraffin and allow them to air dry.
DO NOT DRY THE BEARINGS WITH COMPRESSED AIR.

Needle bearings

Before pushing needle bearings into a cylinder bore, always remove all metallic projections from the bore and its edges. Before pushing in bearings with a press, coat the inside and edges of the bearings with Vaseline.

Gears

Check all the gears and ensure that they do not show any signs of wear or damage. Replace the worn out or damaged gears.

Gaskets, O-rings and flat seals

Always install new gaskets, O-rings, and flat seals. Coat the gaskets and O-rings with Vaseline.

Shaft

Check all shafts showing wear or damage. Ensure that the surface of a shaft carrying a bearing or gasket is not damaged.

Spare parts

Always use CASE spare parts. To order these, refer to the Spare Parts Catalogue and indicate the correct reference number of the CASE spare parts.
Breakdowns caused by the use of parts other than CASE spare parts are not covered by the warranty.

Lubrication

Use only the oils and lubricants specified in the Operator's Manual or the Service Manual.
Breakdowns caused by the use of oils and lubricants not specifically listed are not covered by the warranty.

Torque (- A.90.A.10)

CX75SR

Order of tightening nuts and cap screws.

Tighten alternately so that torque setting remains even.

Cap screws which are fitted with Loctite (look for traces of a white residue on the thread after removal), must be cleaned with a thin oil or a suitable solvent, then dried.

Add two or three drops of Loctite to the cap screw thread, then fit the screw.

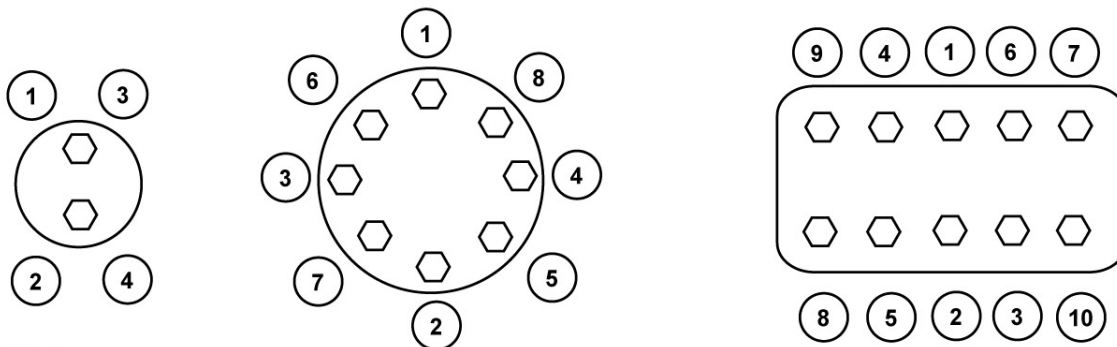

CRIL03H012E01

CRIL03H012E01 1

The numbers in the diagrams represent the order of tightening.

Tightening torque

Where there are no special instructions, tighten cap nuts screws to the torques given in the table below.

Standard torque setting table.

Designation of cap screws (dimensions)		M6	M8	M10	M12	M14	M16	M18	M20
Cap screw	Wrench in mm	10	13	17	19	22	24	27	30
	Torque setting in Nm	6,9	19,6	39,2	58,8	98,1	157,2	196	274
Socket head screw	Wrench in mm	5	6	8	10	12	14	14	17
	Torque setting in Nm	8,8	21,6	42,1	78,4	117,6	176,4	245	343

SPECIAL TORQUE SETTINGS

No.	Component	Screw diameter	Wrench in mm	Tightening torque
(1)*	Travel moto-reduction gear	M16	24	267 - 312 Nm
(2)*	Sprocket	M14	22	173 - 202 Nm
(3)*	Idler wheel	M10	17	63 - 73 Nm
(4)*	Upper roller	M16	24	267 - 312 Nm
(5)*	Lower roller	M20	30	521 - 608 Nm
(6)	Track pad	M14	22	220 - 270 Nm
(7)	Counterweight	M24	36	850 - 992 Nm
(8)	Turntable bearing (chassis and upperstructure)	M16	24	252 - 283 Nm
(9)*	Swing moto-reduction gear	M16	24	267 - 312 Nm
(10)*	Engine	M16	24	265 - 313 Nm
(11)*	Engine mounts	M10	17	64 - 74 Nm
(12)	Radiator	M12	19	36 - 44 Nm
(13)*	Hydraulic pump	M10	17	64 - 74 Nm
(14)*	Hydraulic pump support	M12	Hex	109 - 126 Nm
(15)*	Hydraulic reservoir	M12	19	69 - 78 Nm
(16)*	Fuel tank	M10	17	36 - 44 Nm

INTRODUCTION

No.	Component	Screw diameter	Wrench in mm	Tightening torque
(17)*	Control valve	M12	19	53 - 64 Nm
(18)*	Hydraulic swivel	M10	17	63 - 73 Nm
(19)	Cab	M16	24	78 - 80 Nm

Use Loctite 262 or an equivalent on mounting screws marked with an asterisk (*).

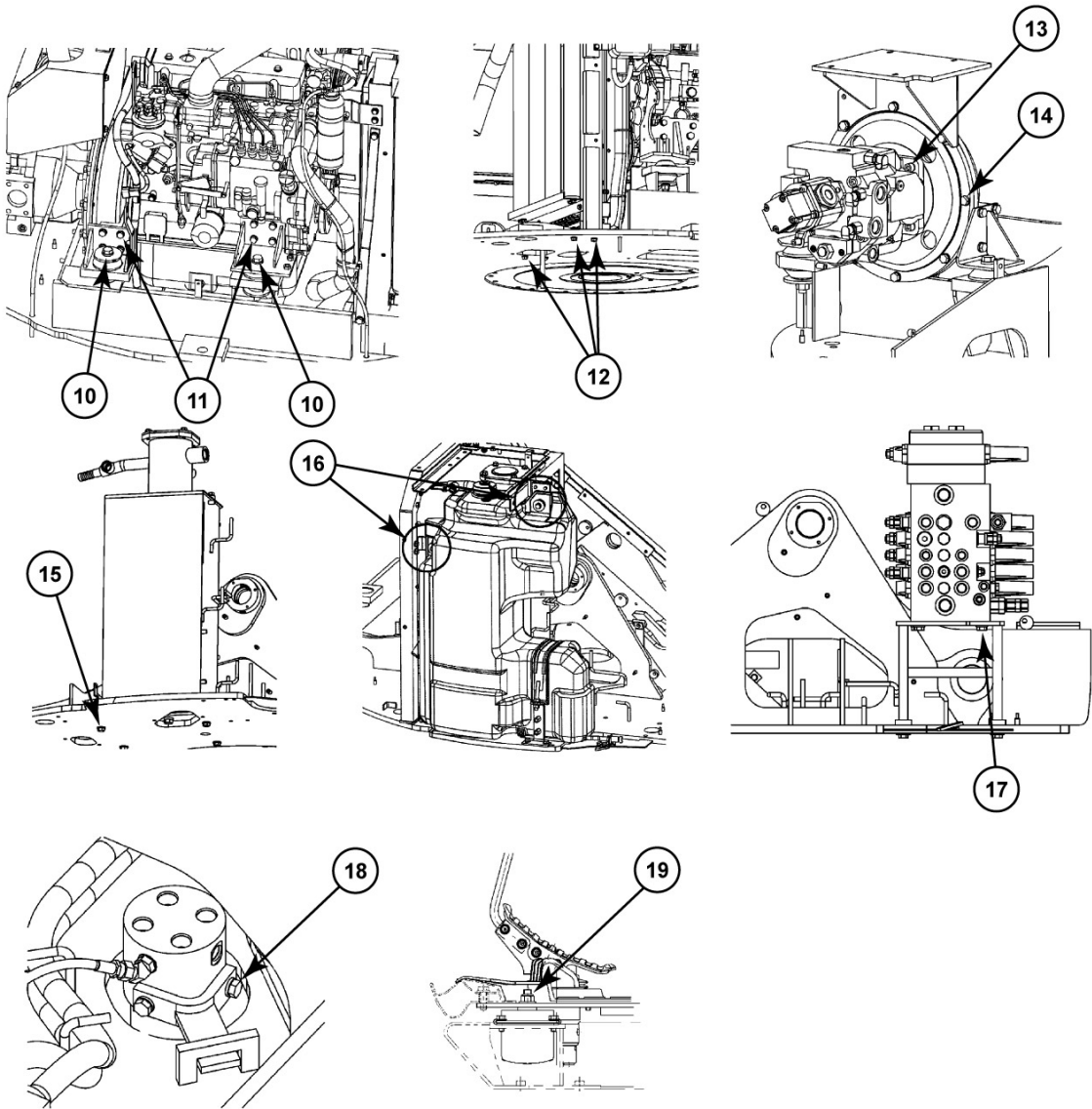

CRIL03H14G01

CRIL03H14G01 2

BUY NOW

**Then Instant Download
the Complete Manual
Thank you very much!**