

CROWN



MAINTENANCE MANUAL



WD2300S SERIES

TABLE OF CONTENTS

MA- SAFETY	PAGE
Symbols Used in the Manual	3
General Safety Instructions	4
Maintenance and Repair Instructions	4
Maintenance and Repair	4
Before Parking the Truck	5
Before Working on the Truck	5
Before Starting the Truck	5
Warning and Instruction Decals on the Truck	5
ITD- INTRODUCTION	PAGE
Introduction	9
General	9
Operator manual	9
Service Training	9
Ordering Spare Parts	9
Using the Manual	10
M1- LUBRICATION & ADJUSTMENT	PAGE
Lifting the Truck	13
Lifting by Crane	13
Lifting with another Forklift Truck	13
Jacking up the Truck	14
Towing the Truck	15
Accessing the Components	16
Power unit cover	16
Control handle	16
Control handle knuckle	16
Mast	17
Platform and side restraint	17
Maintenance	19
Recommended Lubricants and Oils	19
Lubricants	19
Cold Store Trucks	19
Taking the truck out of service	19
Returning the Truck to Service	19
Inspection and Maintenance Schedule	21
Testing the Operation of the Safety Reverse Switch	25
Inspection and Maintenance Schedule	26
Lubrication Points	31
Drive Wheel and Castor Wheels	32
Setting the contact pressure	32
Torques	34

M2- HYDRAULICS	PAGE
Hydraulic Symbols	39
Hydraulic Unit Removal	43
Hydraulic System	44
Function	44
Lifting (Main Lift)	44
Lowering (Main Lift)	44
Lifting (Initial Lift)	44
Lowering (Initial Lift)	44
Hydraulic Reservoir Capacity	48
Changing the Hydraulic oil and Hydraulic Filter	48
Motor & Pump Assembly	50
Hydraulic lines and fittings	50
General Rules for Hydraulic Lines and Connections	50
Bleeding the Hydraulic System	51
Drift Test	51
Disassembly	51
Motor	52
Pump	52
Relief Valve	55
Replacing the relief valve	55
Relief valve setting	55
Relief valve test and setting	56
Testing and setting the load-sensing pressure switches	57
Setting the pressure switch points	58
Pressure switch PS1	58
Pressure switch PS2	58
Pressure switch PS3	58
M3- POWER UNIT	PAGE
Gear Unit	61
Preparatory Measures	61
Tools required:	61
Disassembly	61
Servicing	62
General	62
Gear Unit Disassembly / Assembly	64
Disassembly	64
Assembly	65
Preparing the gear unit	65
Assembling the flange shaft	65
Pinion Shaft Assembly	66
Adjusting the Bevel Wheel Set	66
Checking the Flank Tooth Bearing	67
Final Assembly	67
Re-Assembly	68
Traction motor	68

M4- ELECTRICAL SYSTEM	PAGE
Wire Colour Code	71
Abbreviations	72
Sundry Abbreviations	73
Electrical Wiring Diagrams	74
Electrical Components	76
Traction Pod (POT, FS, RS)	76
Fast / Slow Travel Switch (HSS)	76
Safety Reverse Switch (SAS)	76
Brake Switch (BRS)	76
Horn Switch (HNS1 & 2)	77
Key Switch (KYS)	77
Emergency Disconnect (BD)	77
Fuses (FU)	77
Thermo Switch (THS, optional)	77
Diode D4	77
Diode Block (DB)	77
Platform Logic (PLM)	77
Limit Switch (LMS1)	78
Limit Switch (LMS 2, only for masts > 1700mm)	78
Limit Switch (LMS3, only for masts > 1700mm)	78
Limit Switch LMS4	78
Pressure Switch (PS1)	78
Pressure Switch (PS2)	78
Pressure Switch (PS3)	78
Initial lift Switch	78
Hydraulic Control Module (HCM)	79
Raise / Lower Switches (RAS, LOS)	79
Control Handle Main PCB (Main PCB)	79
Hydraulic PCB (Hydr. PCB)	79
Speed Transmitter PCB (R/T PCB)	79
Heating Option (F/C)	79
Battery	81
General	81
Replacing the Battery	81
Battery Discharge Indicator (BDI)	82
Operation	82
General	83
Battery Discharge Indicator Setting (BDI)	83
Calibration for Wet Batteries	84
Troubleshooting	85
Contactors	86
Inspection	86
Contacts	86
Coils	86
Springs	86
Servicing	87
Dismantling	87
Assembly	87

SEM1 Traction Controller	88
General	88
Precautionary Measures	88
Operating Characteristics	88
Speed control	88
Reduced Travel Speed Zones	89
Downhill Speed Control	89
Regenerative Braking	89
Anti Roll Down Function	89
Hourmeter	89
Self-Diagnostic System	89
Monitored Circuits	90
Safety Mechanisms	90
Incorrect polarity	90
Wiring Errors	90
Temperature protection	90
Start sequence	90
Protection rating	90
Maintenance	91
Replacing the SEM1 Traction Controller	92
Parameter Setting after Replacing the Traction Controller	93
Preparatory Measures	93
Adjustment	93
Status LED	96
Travel Speed Test	97
Programmer	98
General	98
SEM1 Traction Controller Operating Menu	100
General	100
Menu Functions	100
PARAMETER CHANGE	100
TEST	100
ALARMS	100
PROGRAM VACC	100
CONFIG	100
Menu Structure for Folding Platform	101
Parameter Setting, Folding Platform	102
TESTER Menu	105
Max. speed in relation to the reductionlevel	106
.....	106
ALARMS Menu	107
Traction Pod	110
Calibrating the Potentiometer, PROGRAM VACC Menu	110
Preparatory Measures	110
Calibration	110
CONFIG Menu	112
SET MODEL	112
SET OPTIONS	112
ADJUSTMENTS	112
Traction Controller Safety Test	113
WD2300S Platform Logic Box	114
Platform Logic Controller, Part No. 816050	114
.....	117
Checking the Platform Logic	118

Hydraulic Control Module (HCM), Part No. 816177	119
Operation	119
Calibrating the HCM	121
Electric Motors	122
General Maintenance Instructions	122
Preparatory Measures	122
Important Maintenance Instructions	122
Traction Motor Maintenance	123
Access to brushes	123
Maintenance	123
Armature	124
Bearings	124
Pump Motor Maintenance	125
Access to brushes	125
Maintenance	125
Armature	125
M5- BRAKE	PAGE
Brake	129
Dismantling	130
Test and Inspection	130
Assembly	131
Air Gap Setting	132
Braking Torque Setting	132
Brake Test	133
M6- STEERING	PAGE
Control Handle Return Springs	137
Adjustment	137
Disassembly	137
Installation	138
Control Handle Grip	139
Main Components	139

Control Handle Grip Components	140
Hand Grip Shells	140
Upper and lower shell removal	140
Upper and lower shell assembly	142
Switch Unit	142
Disassembly	142
Switch unit assembly	143
Disassembly	144
Installation	144
Hydraulic PC Board	144
Disassembly	144
Installation	145
Main board removal/installation	145
Potentiometer	146
Disassembly	146
Installation	147
Safety Reverse Switch	147
Disassembly	147
Installation	148
Horn Switch	149
Disassembly	149
Installation	149
Hand Grip	149
Disassembly	149
Installation	150
Initial Lift Switch	150
Disassembly	151
Installation	151

M7- MAST/LIFT MECHANISM	PAGE
Lift Linkage	155
Adjusting the Fork Height	155
Fork Adjustment	156
Adjusting the fork height	156
Mast	158
General	158
Torque Requirements	158
Lifting Gear Minimum Capacity	158
Mast Removal	158
Installation	160
Fork Carriage Removal	161
Fork Carriage Installation	161
Fork Carriage Adjustment	162
Mast Maintenance	163
Lubricating Roller Tracks	163
Mast Shims	164
Lowering Plumb Test	166
Preparatory Measures	166
Carrying Out The Vertical Plumb Test	166
Lift Limit Cutout / Initial Lift	167
Lift Limit Cutout Setting	167
LMS 2-4 Limit Switch Adjustment	168
Lift Limit Cutout Setting	168
Connecting the Lift Limit Switches	170

Lift Chains	171
General	171
Inspection	171
Cleaning	172
Wear	172
Freedom of Movement of Chain Links	173
Chain Tension	173
Chain Anchor and Pulleys	173
Worn Connection Plates	174
Protruding or Turned Chain Pins	174
Corrosion	175
Chain Lateral Wear	175
Uneven Chain Tension	175
Misaligned Lift Components	175
Lift Chain Lubrication	176
Separating Lift Chains	177
Separation	177
Fork Tines	178
General	178
Terms	178
Fork Identification	178
Repairs	179
Fork Inspection	179
Verticality Test	180
Fork Blade Warping	181
Measuring the Fork Tip Width	181
Fork Tine Height Difference	181
Fork Stop	181
Fork Blade Wear	182

M8- CYLINDERS	PAGE
Cylinders	185
General	185
Safety when working on hydraulic systems	185
General Instructions for Repairing Hydraulic Components	185
General	185
Plunger Cylinders	186
Piston Cylinders	188
Single-Acting Cylinder	189
Double-Acting Cylinder	189
Rod Seal Assembly	190
General	190
Large Rod Seal Assembly	191
Small Seal Rod Assembly	192
Rod Seal Assembly, Sealing Lip First	193
Initial Lift Cylinder	195
Operation	195
Disassembly	196
Inspection	197
Replacing the rod seal	197

Free Lift Cylinder	198
Seal Replacement	198
Installing Carriage Cylinder	200
Cylinder Bleeding and Flushing	201
Free lift cylinder bleeding	201
Flushing – Mast Lift Cylinders and Free Lift Cylinders	201
Drift Test	201
M9- PLATFORM	PAGE
Mechanical Adjustment	205
Platform Switch (PLS) Adjustment	207
Platform Cushioning	208
Layering the disk springs	208
Side Restraint, Mechanical Adjustment	209
DIA- ELECTRICAL WIRING DIAGRAMS	PAGE
Standard Diagrams	214
Overview	214
Traffic Control Logic Circle	216
Traffic Control Load Circle	217
Hydraulic Traffic Modul and Diodes Block	218
Power Unit Control Circle	219
Control Handle Control Circle	220
Platform & Mast Control Circle	221
Platformmodul	222
Option Wiring Diagrams	224
Overview	224
Traffic Control Logic Circle	226
Traffic Control Load Circle	227
Hydraulic Traffic Modul and Diodes Block	228
Power Unit Control Circle	229
Control Handle Traffic Circle	230
Platform & Mast Traffic circle	231
Platformmodul	232
Power Cables	234
Legend	235
Main Wire Harness	236
Folding platform, all versions	236
Control Handle Wire Harness	237
Horn Switch Wire Harness	238
HYD-HYDRAULIC DIAGRAMS	PAGE
Hydraulic Diagrams	242

CROWN



SAFETY

Notes:

Symbols Used in the Manual

To provide guidance and clearly identify potential hazard points, we have used graphic illustrations in the manual:

Danger

This symbol indicates a danger to life.

You or other people could be seriously or fatally injured if you fail to comply with this safety instruction.

Warning

This symbol represents a risk of injury and/or potentially significant material damage.

You or other people could be seriously injured and/or significant material damage could occur if you fail to comply with this safety instruction.

Caution

This symbol represents potential minor injuries and/or potential minor material damage.

You or other people could be slightly injured and/or minor material damage could occur if you fail to comply with this safety instruction.

Information

This symbol is used with additional information and instructions.

Option

Option

This symbol is used with text describing optional equipment. This is not included with the standard version.

General Safety Instructions

Maintenance and Repair Instructions

Danger



Observe the safety instructions in the maintenance manual and the truck operator manual.

Failure to do so could result in serious or even fatal injuries to maintenance and other personnel.

Motorised trucks can become hazardous if maintenance and servicing work are neglected. For this reason maintenance and inspections must be performed at sufficiently short intervals. There must be suitably trained personnel and proper guidelines at your place of work.

Danger



Observe all relevant national and local safety regulations for maintenance and repair work.

Failure to do so could result in serious and even fatal injuries to maintenance and other personnel.

Maintenance and Repair

1. Always carry out work in accordance with the test and maintenance schedule enclosed in these maintenance instructions and any applicable service bulletins.
2. Only qualified and authorised personnel may carry out work on the truck.
3. Keep fire protection equipment at hand and do not use a naked flame to check fluid levels or to test for leaks.
4. Use groundwater neutral, non-flammable solvents for cleaning. Always perform cleaning work over an oil separator. Protect the electrical system against damp.
5. Keep the work place and battery charging station clean, dry and well ventilated.
6. Do not allow oils to penetrate the ground or the drain system. Used oil must be recycled correctly. Oil filters and dehumidifying inserts must be treated as special waste. Observe the local authority regulations.
7. Immediately neutralise and thoroughly rinse any spilled battery fluid.
8. Keep the truck clean. This will facilitate tracing loose or faulty components.
9. Maintain the legibility of the data capacity plate and data plate, warning and instruction decals.
10. Truck modifications and additions may only be performed with Crown's prior written approval.
11. The reliability, safety and suitability of Crown trucks can only be ensured by using original Crown parts.

Before Parking the Truck

- Brake until the truck comes to rest.
- Lower the fork carriage fully.
- Apply the parking brake.
- Switch off the truck and remove the key.
- When parking on a slope or incline always chock all wheels.

Before Working on the Truck

- Jack up the truck so that the drive wheel is clear of the ground. Apply the Emergency Disconnect and disconnect the battery.
- Prevent the truck from rolling away and lowering.
- When working on the mast, fork carriage or lifting mast always apply a chock to prevent accidental lowering.
- Allow sufficient room for manoeuvre when testing the truck, to avoid endangering yourself and other people.

Before Starting the Truck

- Test the safety mechanisms.
- Get into the travel position.
- Test the lifting mechanism, travel direction switch, speed control, steering, warning mechanism and brakes.

Warning and Instruction Decals on the Truck

In the course of periodic maintenance work, check that the warning and instruction decals on the truck are complete and legible.

- Clean any dirty decals.
- Replace any faulty or missing decals.

A description and the location of the warning and instruction decals used on the truck are given in section 10.9 of the spare parts manual.

Notes:

CROWN



INTRODUCTION

Notes:

Introduction

General

The present manual is designed for Customer Service engineers who wish to familiarise themselves with the maintenance work required for the various truck components.

It also contains troubleshooting sections which can be used to identify and remedy truck faults.

Information



This book is not an operator manual. It is designed solely for specialist personnel who have been trained and authorised by Crown to carry out the work described in the manual.

This manual therefore contains fewer and less detailed warnings than the operator's manual, as the latter is aimed at persons who have very little or no prior experience at all.

Operator manual

This manual contains no operating instructions. An operator manual is supplied with the vehicle. Additional copies can be ordered as required.

With the help of this manual you and your personnel will be able to ensure the long service life, operational safety and error free functioning of your Crown truck.

Service Training

Crown offers the appropriate truck related training for service personnel. Details of this training can be obtained from Crown on request.

Ordering Spare Parts

The maintenance manual does not cover spare parts. These are listed in a separate manual.

Spare parts can be ordered by quoting:

- The truck specification number
- The truck model number
- The truck serial number

This information can be found on the truck data plate. It is essential to provide this information to ensure accurate, fast and efficient order processing.

Please refer to the specification sheets for the utilisable loads, technical data and dimensions for this series. Brochures can be obtained from your Crown dealer or from the following address:

CROWN Gabelstapler GmbH & Co.KG

Moosacher Str.

80809 Munich

Germany

Tel.: +49 (0)89 / 93 002 -0

Fax: +49 (0)89 / 93 002 -175 or 133

Using the Manual

This manual is divided into sections. The following table shows how the manual is structured.

Maintenance manual structure	
Section	Description
IDX	Index
MA	Safety instructions
ITD	Introduction
1	Lubrication and Adjustment
2	Hydraulic system maintenance
3	Power unit maintenance
4	Electrical system maintenance
5	Brake system maintenance
6	Steering system maintenance
7	Mast / lift mechanism maintenance
8	Cylinder maintenance
9	Folding platform
DIA	Electrical wiring diagrams
HYD	Hydraulic diagrams

CROWN



LUBRICATION & ADJUSTMENT

Notes:

Lifting the Truck

Danger



Make sure the crane / truck and the lifting gear have the required capacity. If the crane or lift truck crash or if a load falls, fatal injuries could result.

Required capacity (WD without battery): **900 kg**

The outriggers must be fully raised and the forks fully lowered.

Lifting by Crane

Attach lifting gear as shown in the following diagram and prevent the truck from slipping (see arrow).



G_WD-lift-crane

Lifting with another Forklift Truck

The WD 2300 S can be raised at an angle using a forklift truck.

- Position the forks of the truck which is doing the lifting as shown by the diagram below.
- Place a chock approx. 90 mm thick between the outriggers of the WD 2300 S and the corresponding fork of the truck doing the lifting.
- Secure the WS 2300 S firmly to the forks of the truck doing the lifting (e.g. with straps).

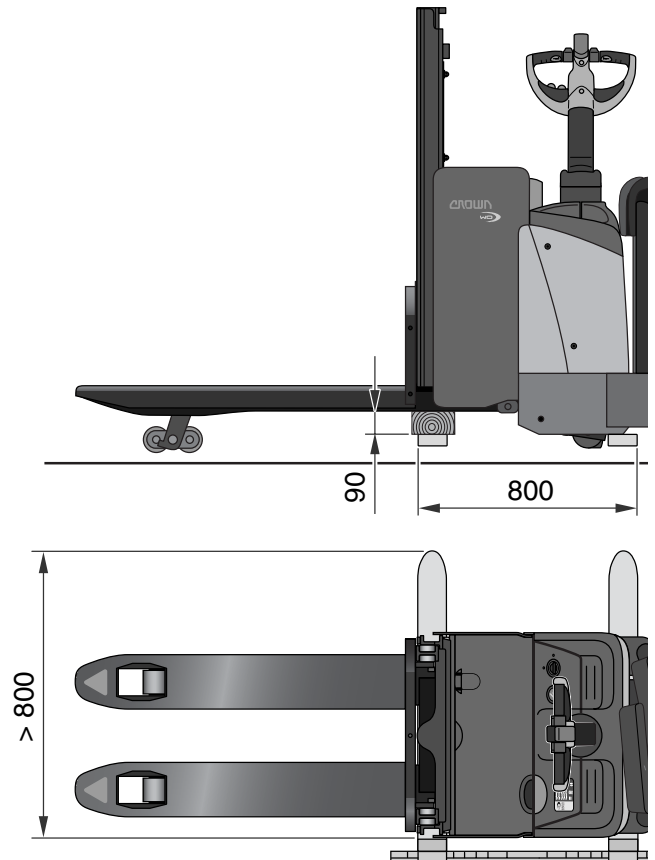

G_WD-on-forks

LUBRICATION & ADJUSTMENT

Jacking up the Truck



Jacking up the Truck

Danger



Always support a raised truck with wooden blocks or other appropriate equipment to relieve the jack.

Never reach your hands or other parts of your body under the truck before it has been supported, or when jacking up the truck.

Improper handling of the truck or of the auxiliary equipment can result in fatal accidents.

The outriggers must be raised in full in order to jack up the truck.

- Place wedges (1) in front of both load wheels.
- Apply a jack with sufficient capacity (>800 kg) to the centre of the skirting rail and raise the truck to a maximum of 20 mm (2).
- Place sufficiently sized hard wooden blocks on both sides underneath the chassis and lower the truck onto the blocks (3).
- Now raise the outriggers with the jack.

- Place a hard wooden block underneath and lower the truck onto it (4).

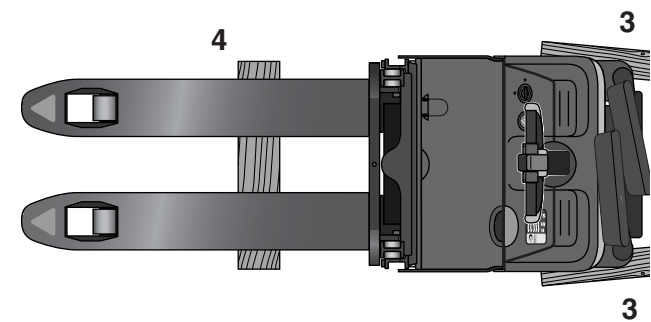
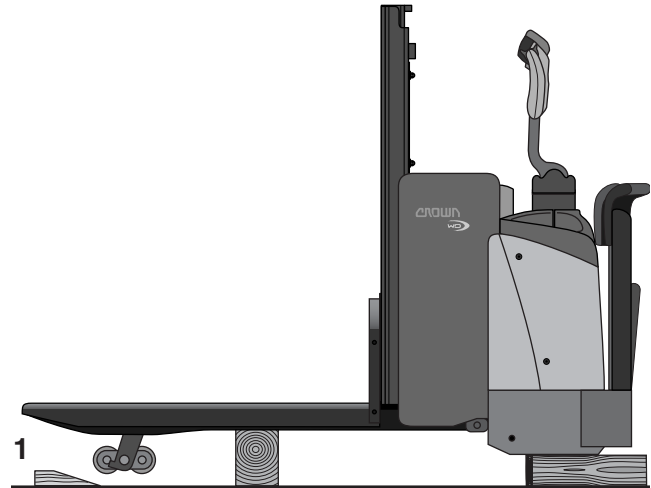

G_WD-jack-up

Towing the Truck

When the truck is de-energised, the brake (acting on the drive wheel) is applied. To remove the truck from an aisle, for example, it can be raised and pulled by a forklift truck. Capacity required (WD 2300 S unladen): 900 kg . The load wheels remain on the ground when the truck is towed.

- Position the forks as shown in the diagram.

Take care not to damage the castor wheels on either side of the truck.

- Raise the truck (at its front) approx. 40 mm.

Caution



The drive wheel must be lifted from the floor!

Otherwise the truck could be damaged.

Pull the truck slowly straight forward (as indicated by the black arrow).

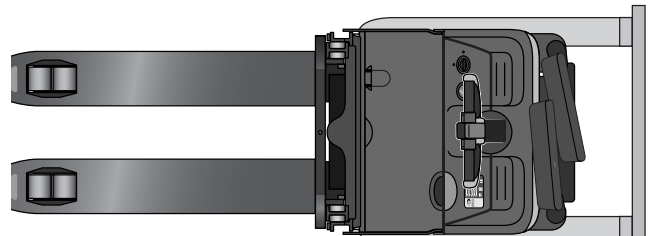
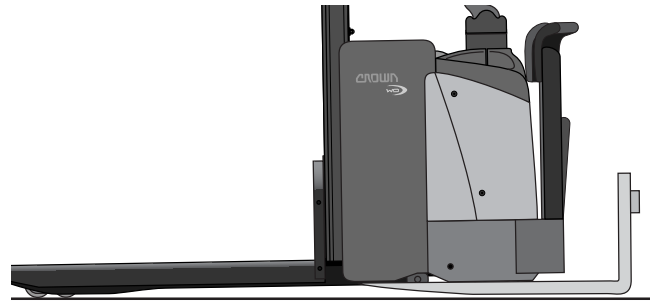

G_WD-tow

Accessing the Components

The following is a list of covers, panels etc. which must be removed prior to carrying out repairs and / or servicing in order to access the components. Refer to the illustrations in this chapter which will help you to locate the parts.

Warning



Always remove the battery connector before carrying out maintenance work. This applies in particular if the connector and electrical connections have to be separated.

Power unit cover

Provides access to:

- Traction motor TM
- Power unit
- Brake
- Pump motor (PM), lift contactor (P), lowering valve (SV1, SV2, SV3)
- Hydraulic oil reservoir
- Horn (HN)
- Diode block (DB)
- Traction control module (TCM)
- Main contactor (line)
- Fuse FU1 (travel power fuse)
- Fuse FU2 (raise)
- Diagnostic LED for TCM (LED)
- Hydraulic control module (HCM)

- Unigage (TT/BDI)
- Key switch (KYS)
- Fuse 3, FU3 (signal system)
- Fuse 4, FU4 (signal system)
- Platform module (PLM)
- Pressure switches (PS1, PS2, PS3)

Control handle

Provides access to:

- Horn switches (HNS1 & HNS2)
- Main Lift – lower switches (LOS1, LOS2)
- Main Lift – lift switch (RAS)
- Fast / Slow Travel Switch (HSS)
- Safety Reverse Switch (SAS)
- Potentiometer (POT), forward travel switch (FS), reverse travel switch (RS)
- Lower switch (ILS Lower) initial lift
- Main switch (ILS Lift) initial lift

Control handle knuckle

Provides access to:

- Brake switch (BRS)

Mast

Provides access to:

- Mast switch:
 - Mast 1700 mm: Speed reduction limit switch (LMS4)
 - Mast 2100 mm: Speed reduction limit switches (LMS4, LMS3, LMS2)

Platform and side restraint

Provides access to:

- Travel mode switches (GCSL, GCSR, PLS)

LUBRICATION & ADJUSTMENT

Accessing the Components

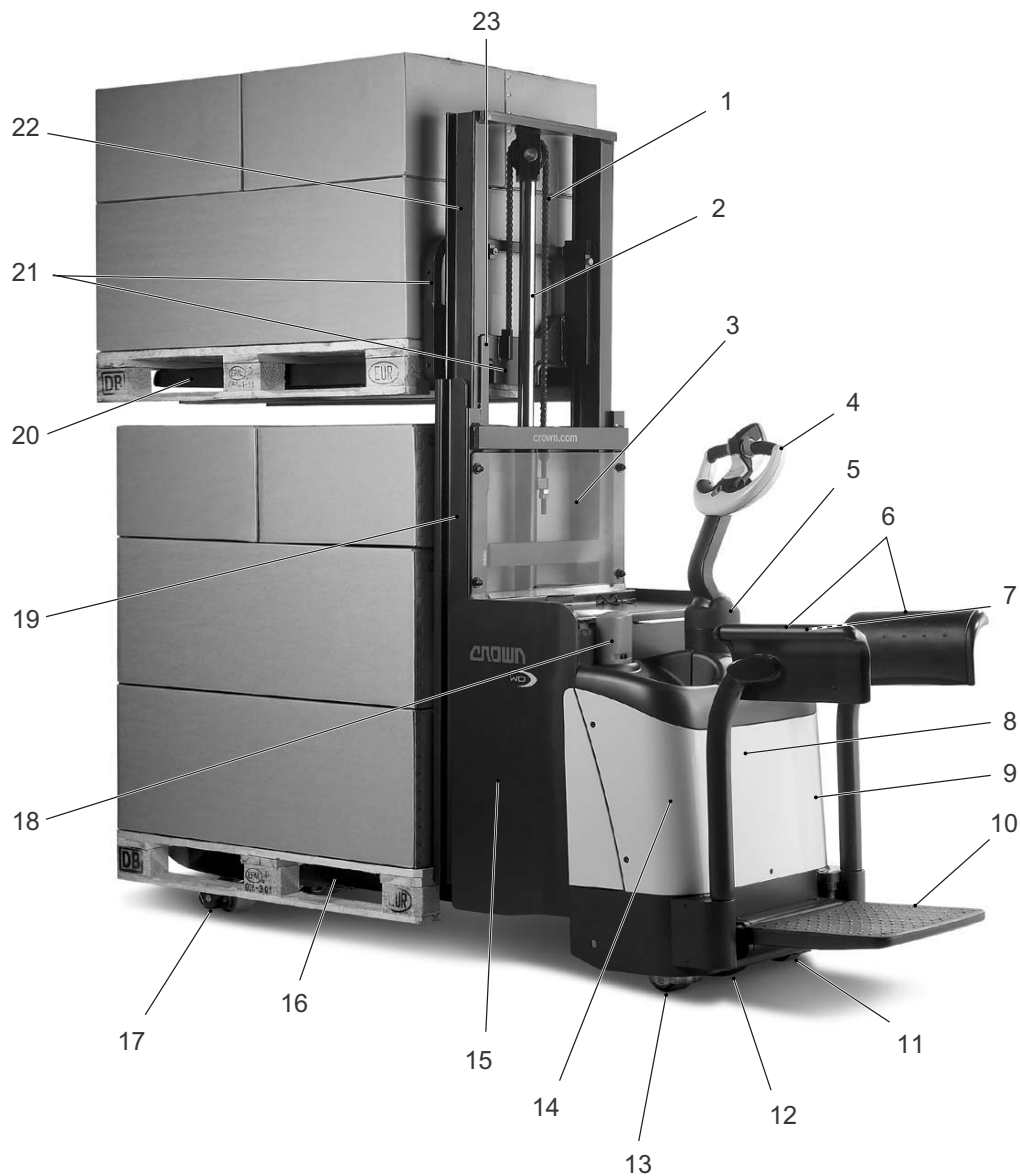

MS-3400-001

- | | | | |
|----|---------------------------|----|---------------------------------------|
| 1 | Lift chain | 13 | Castor wheel |
| 2 | Mast lift cylinder | 14 | Pump unit & hydraulics manifold block |
| 3 | Safety shield | 15 | Battery compartment |
| 4 | Control handle | 16 | Outrigger |
| 5 | Control handle knuckle | 17 | Load wheels |
| 6 | Side restraint | 18 | Battery / battery connector |
| 7 | Display panel | 19 | Outer mast |
| 8 | Drive unit / brake | 20 | Fork |
| 9 | Controller and contactors | 21 | Fork carriage |
| 10 | Platform | 22 | Inner mast |
| 11 | Castor wheel | 23 | Mast limit switch |
| 12 | Drive wheel | | |

Maintenance

Recommended Lubricants and Oils

Lubricants

The next page shows typical lubricants used by Crown itself in its facilities. However, you can use any lubricants provided they meet the same technical criteria.

Cold Store Trucks

Special hydraulic oil, lubrication oil and grease must be used for cold store trucks operating in low temperature conditions (see table on following page). An anticorrosion fluid (Crown no. 805236-004) must be applied regularly to all screws, washers, nuts, pins, retaining rings etc. Carefully protect all electrical connections and components against corrosion. For detailed information, refer to chapter 4.

Service intervals must be adapted to the conditions of use. This means they must be reduced as far as possible to prevent excessive wear.

Taking the truck out of service

- If the truck is to be out of service for 3 months or more, proceed as follows:
- Disconnect the battery.
- De-commission the battery in accordance with the manufacturer's instructions.
- Clean the truck*. Carry out lubrication in accordance with the Maintenance Manual.
- If the truck is to be stored in hostile conditions (e.g. saline atmosphere) treat the surface of the truck with a suitable preservative to prevent corrosion.

- Do not park the truck in the open air or in a humid environment. The ideal place is a dry room where the temperature and air humidity are reasonably constant. If the truck has to be covered, use an air-permeable material. Do not use plastic sheets. Otherwise, condensation may form.
- Jack up the truck. Lower the chassis onto suitable wooden blocks so that the wheels clear the ground (prevents the wheels from flattening from constant pressure).
- Every 3 months connect the battery, carry out a daily inspection and activate all the truck functions. Finally, disconnect the battery again.

Returning the Truck to Service

To return the truck to service, proceed as follows:

- Remove any anti-corrosion film (apart from that provided for cold store use) *.
- Jack up the truck, remove the wooden blocks, lower the truck.
- Charge the battery or fit a charged battery.
- Connect the battery.
- Carry out the daily inspection.

*** Do not apply high pressure cleaning agents and/or solvents to the truck. Do not use metal brushes! Do not wet clean the electrical system and do not use flammable solvents.**

LUBRICATION & ADJUSTMENT

Maintenance



Lubricant Type	Product Description	Manufacturer	Crown Part No.	Type
Grease (multi-purpose)	Aralube HLP2 LM-Grease Regulus A2 Beacon EP2 EP2 Mobiluxe EP2 Retinax LX LGWMI	Aral Castrol Century Esso Maxol Mobil Shell SKF	053002-001	B
Low temperature grease	Aralube SKL2 Unirex Lotemp EP	Aral Mobil	053002-005	BB
Hydraulic oil	Vitamin GF 32 Hyspin AWS-32 Nuto H32 DTE 24 Tellus 32 Hydran LZ 32 B110	Aral Castrol Esso Mobil Shell Finol Fuchs Mineralölwerke GmbH	053001-003	D
Low temperature hydraulic oil	Deutz Oel HVI 32	Klockner	053001-009	DD
Transmission oil	Hyp 85W90 GX-D 85W90 Mobilube HD85W90 Spirax MB90	Aral Esso Mobil Shell	053002-004	A
Lowtemperature transmission oil	Mobil SHC 624	Mobil	053002-009	AA

Lubricants	Product Description	Application	Crown Part No.
Anti-corrosive agent	Tectyl	Anti-corrosive agent for cold store trucks.	805236-004
Clearseal paint	2K clearseal paint	Acid-resistant clearseal paint for traction controllers used in cold stores.	805236-003

BUY NOW

**Then Instant Download
the Complete Manual
Thank you very much!**