



Service Manual

MDGBA
MDGCA
MDGCB

MDGGA
MDGDA
MDGDB

MARINE GENERATOR SETS



Supplement 960-1033

Date: 2-93

Insert with-

Title: MDG Series Service Manual

Number: 960-0506

Beginning with Spec C, these Marine (Sea Aux) models use a new mechanical governor and an optional electronic governor. Add this information to Section 3 of your Service manual, 960-0506.

MECHANICAL GOVERNOR

Mechanical Governor Adjustments: B-Series Engines—Beginning Spec C

Output frequency (50 Hz or 60Hz) can be adjusted by turning the governor speed adjusting screw while the engine is running at its normal operating temperature under full load. Adjust droop to within five percent of nominal frequency (3 Hertz for 60 Hertz sets and 2.5 Hertz for 50 Hertz sets). Check

operation under various loads and increase droop if the governor hunts. Readjust full-load frequency if droop is adjusted.

Do not adjust the idle adjusting screw; it is factory set and sealed.

CAUTION Do not adjust the idle speed screw or break its wire seal. Doing so can void the generator set warranty.

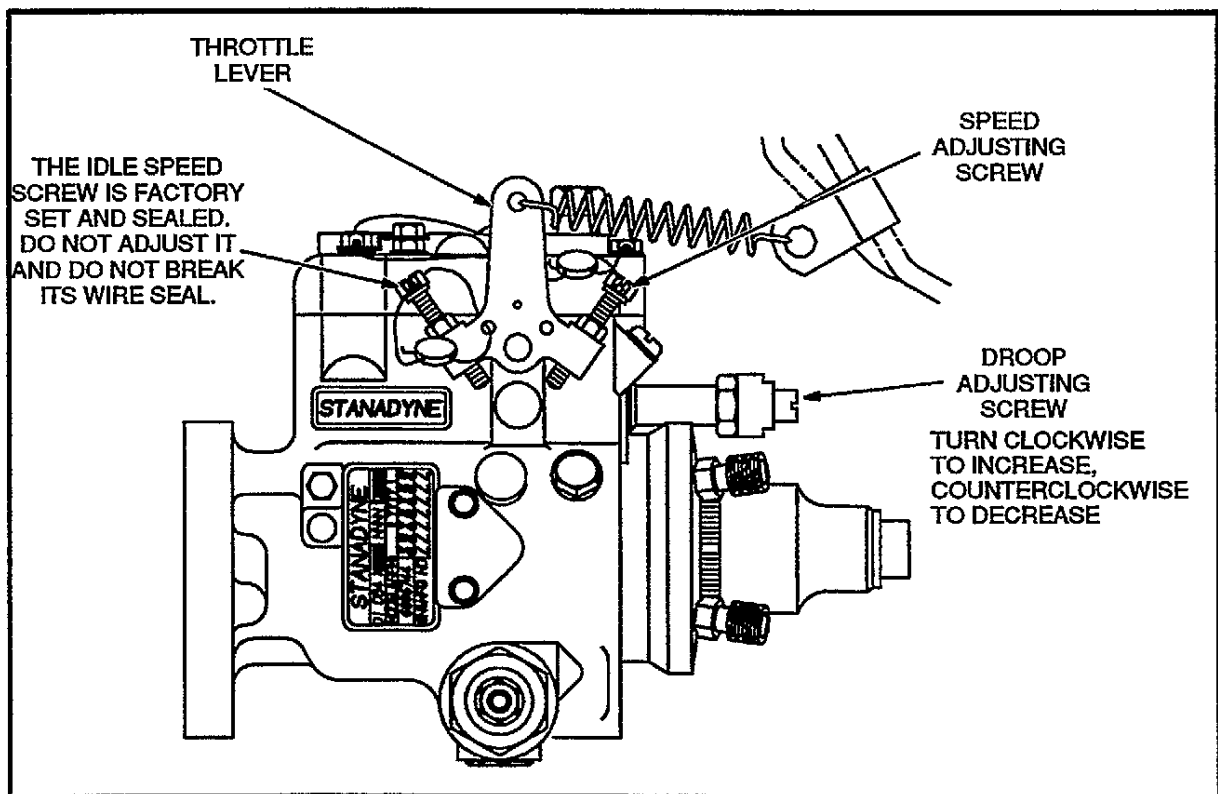

FIGURE 1. MDG SERIES MECHANICAL GOVERNOR—BEGIN SPEC C

Linkage Adjustments: B-Series Engines—Beginning Spec C

Figure 2 illustrates the arrangement of electric governor components on B-Series engines.

If the injection pump has been replaced, it will be necessary to adjust the position of the throttle lever before connecting the actuator linkage. The throttle lever is on the side of the pump away from the engine. See Figure 1.

1. Operate the set and disconnect all loads after the engine has warmed up to normal operating temperature.
2. Loosen the locknut on the throttle lever speed adjusting screw and turn the screw counter-clockwise to increase engine speed to 1980 RPM (66 Hertz) for 60 Hertz sets or to 1650 RPM (55 Hertz) for 50 Hertz sets.
3. Set the locknut. Leave the spring in place to maintain the position of the throttle lever.

CAUTION *Do not adjust the idle speed screw or break its wire seal. Doing so can void the generator set warranty.*

4. Move fuel pump stop lever (inboard lever) forward, slowly decreasing fuel until the engine stops. The stop lever must be in this position when linkage is connected.

Assemble the linkage as follows.

5. Thread the locknut onto the male swivel-end link. Then thread the female link five turns onto the male link and set the lock nut.
6. Secure the male end of the link to the injection pump lever on the engine side of the pump. Make sure to tighten two nuts on the screw before connecting the swivel end of the link to the injection pump lever.
7. Loosely thread the locknut and clevis onto the actuator shaft.
8. Rotate the injection pump lever to the established Stop position (Step 4). Turn the clevis on the actuator shaft until the hole in the link swivel registers with the holes in the clevis and connect the clevis and link with the screw, nut and lock washer as shown.
9. Tighten the clevis locknut on the actuator shaft.

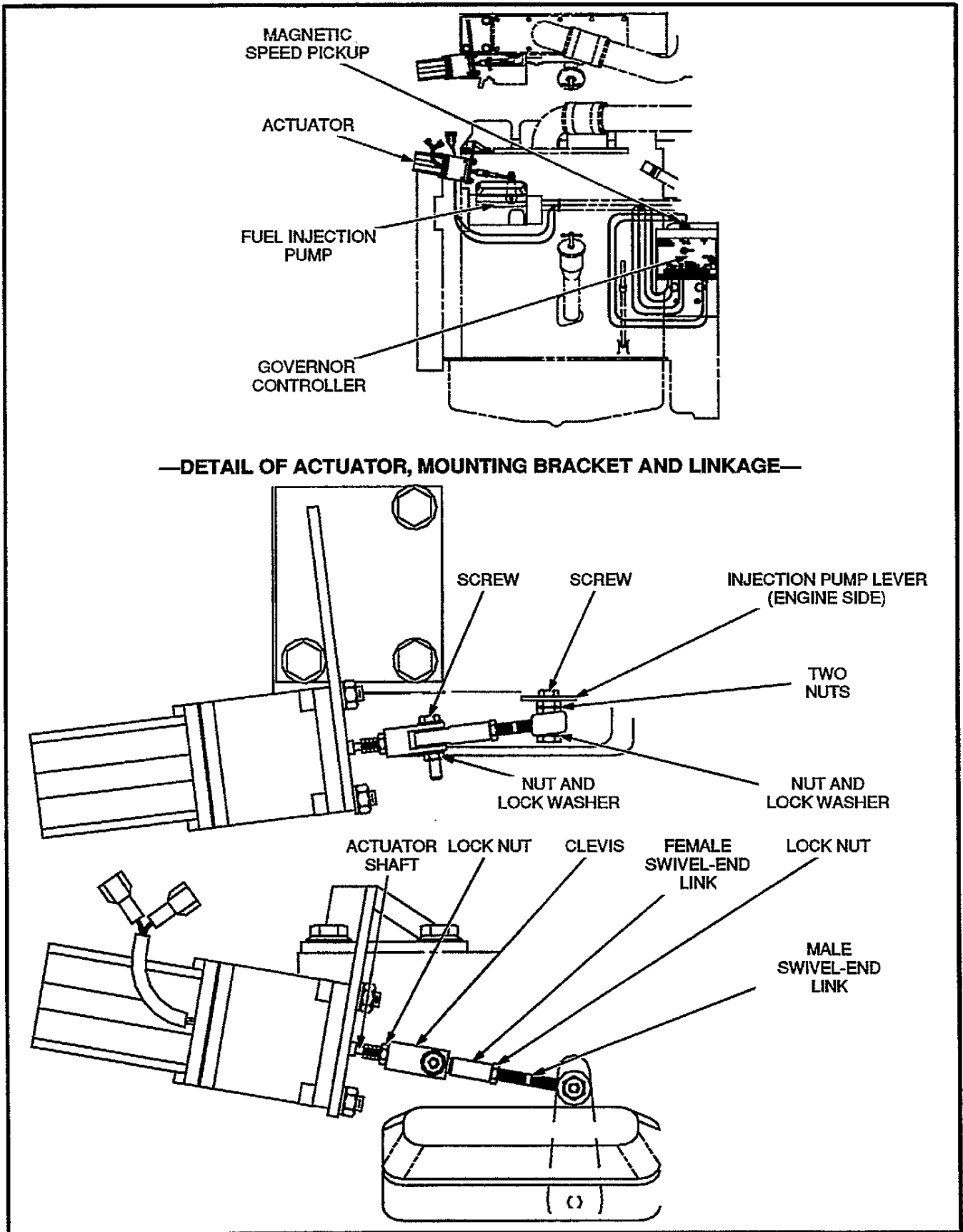

FIGURE 2. ELECTRONIC GOVERNOR LINKAGE - BEGIN SPEC C

ELECTRIC GOVERNOR

Electric Governor Adjustments: B-Series Engines—Beginning Spec C

If necessary, adjust the linkage according to Figure 2, wire the controller according to Figure 4 and install the magnetic speed pickup unit according to Figure 5. Then adjust the governor controller as follows:

1. Push both selector switches (S1, S2) on the controller to their OFF positions.
2. Note that the pots (potentiometers) on the controller are adjustable from zero to 100 percent and are marked off in divisions of ten percent. The speed pot has a 20-turn adjustment range. Set the pots initially as follows:
 - Gain 20%
 - I 20%
 - D 30%
 - Drop 0%
3. If a remote speed pot is used, set it at its mid-point.

4. Start the set and adjust the **Speed** pot to obtain the required output frequency: 60 Hertz (1800 RPM) or 50 Hertz (1500 RPM). Warm up the set under load until it is up to normal operating temperature.
5. Disconnect the load and turn the **GAIN** pot to 100 percent or until operation becomes unstable. Then turn the pot counterclockwise until operation again becomes stable.
6. Adjust **D** as in Step 5.
7. Adjust **I** as in Step 5.
8. Readjust **Speed** if necessary.
9. Manually push the throttle to the minimum speed position and hold it there until the engine reaches minimum speed. Release the throttle and observe speed overshoot. Two to Five Hertz overshoot may be acceptable. If overshoot is unacceptable:

Turn the "I" potentiometer clockwise to lessen overshoot. If there is a small hunt at steady state, turn the "I" potentiometer slightly counterclockwise until stable.

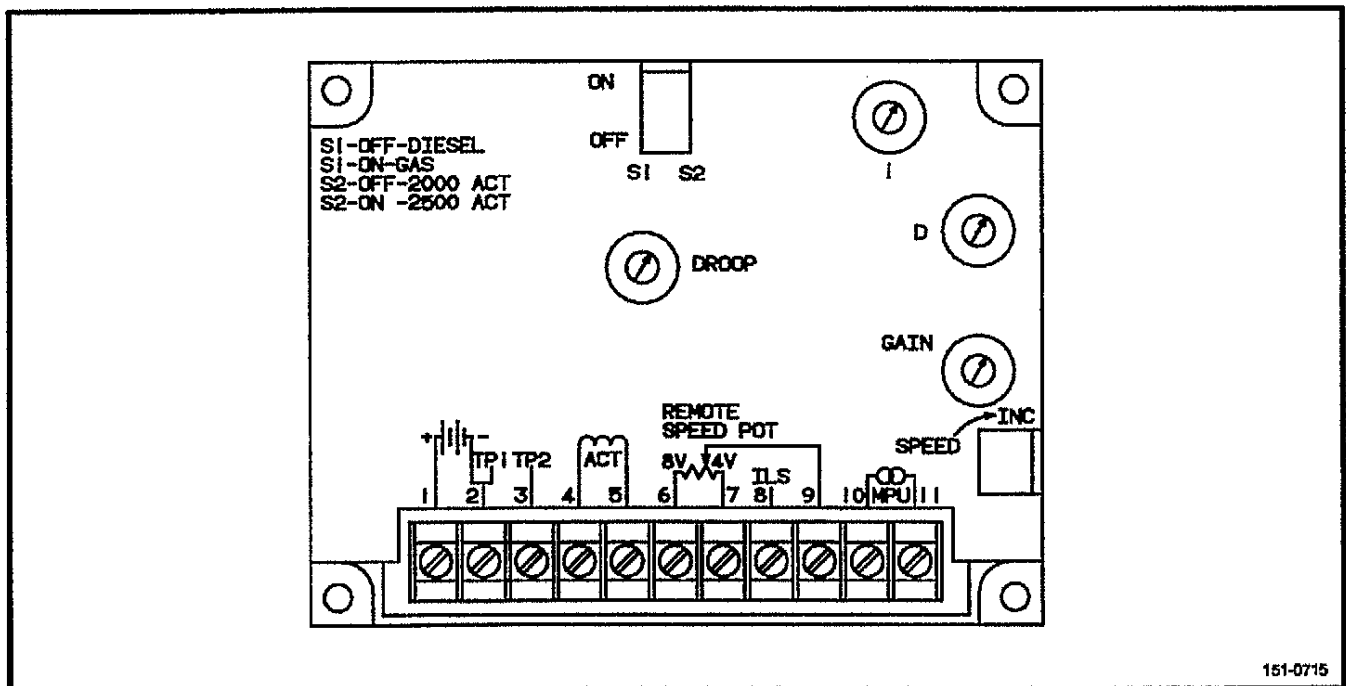

FIGURE 3. GOVERNOR CONTROLLER TERMINALS, SWITCHES AND ADJUSTING POTENTIOMETERS

Electric Governor Wiring

Wire the governor according to Figure 4.

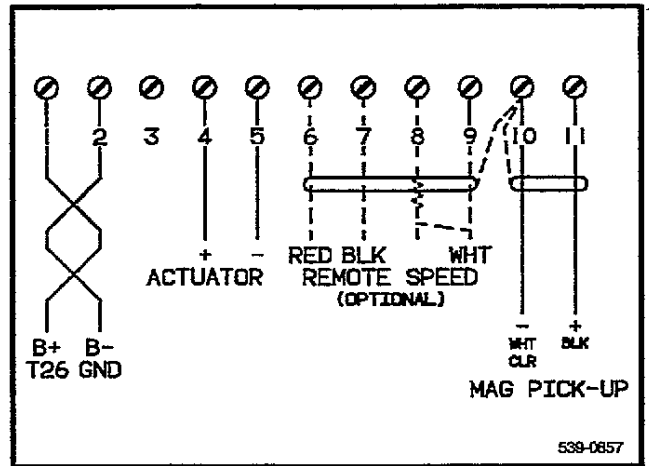

FIGURE 4. WIRING THE GOVERNOR

Magnetic Speed Pickup Unit Installation

To install the magnetic speed sensor, bar the engine until a gear tooth on the flywheel lines up in the center of the mounting hole. Thread the sensor in gently by hand until it just touches the gear tooth. Back it out one quarter turn and set the locknut.

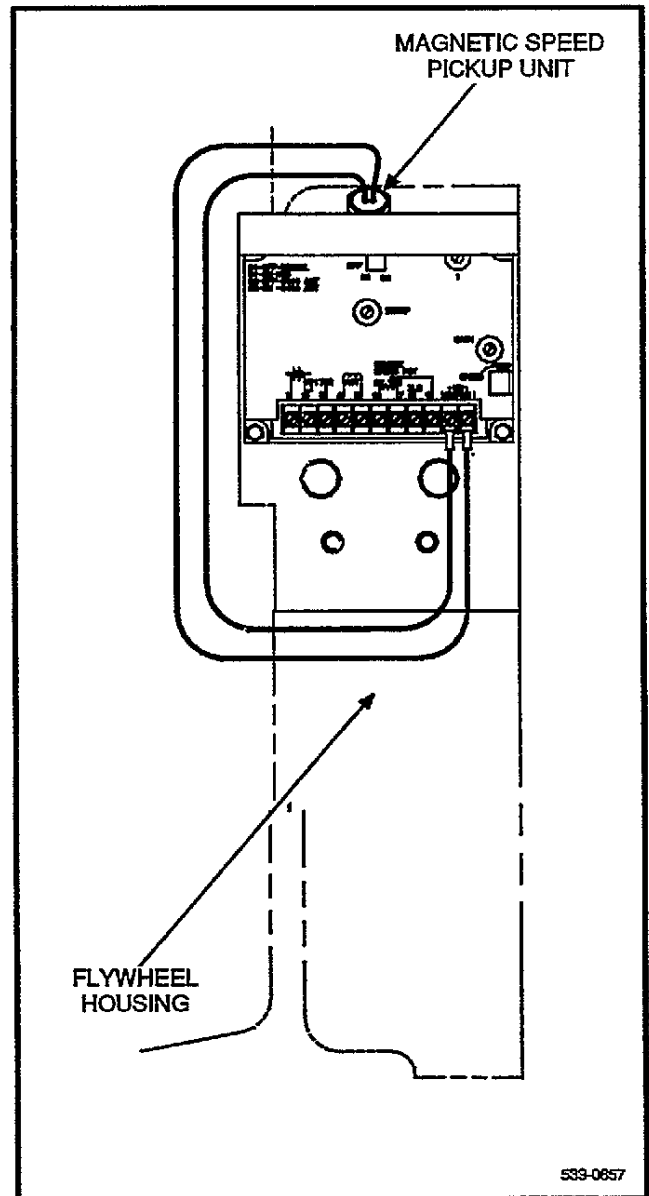

FIGURE 5. MAGNETIC SPEED PICKUP UNIT

Safety Precautions

Before operating the generator set, read the Operator's Manual and become familiar with it and your unit. Safe and efficient operation can be achieved only if the unit is properly operated and maintained. Many accidents are caused by failure to follow fundamental rules and precautions.

Throughout this manual you will notice symbols which alert you to potentially dangerous conditions to the operator, service personnel, or the equipment itself.

⚠ DANGER This symbol warns of immediate hazards which will result in severe personal injury or death.

⚠ WARNING This symbol refers to a hazard or unsafe practice which can result in severe personal injury or death.

⚠ CAUTION This symbol refers to a hazard or unsafe practice which can result in personal injury or product or property damage.

FUEL, ENGINE OIL, AND FUMES ARE FLAMMABLE AND TOXIC. Fire, explosion, and personal injury can result from improper practices.

- Benzene and lead, found in some gasoline, have been identified by some state and federal agencies as causing cancer or reproductive toxicity. When checking, draining or adding gasoline, take care not to ingest, breathe the fumes, or contact gasoline.
- Used engine oils have been identified by some state or federal agencies as causing cancer or reproductive toxicity. When checking or changing engine oil, take care not to ingest, breathe the fumes, or contact used oil.
- Do not fill fuel tanks with the engine running. Do not smoke around the generator set area. Wipe up any oil or gas spills. Do not leave oily rags in engine compartment or on the generator set. Keep this and surrounding area clean.
- Inspect fuel system before each operation and periodically while running.
- Equip the engine fuel supply with a positive fuel shutoff.
- Always disconnect the battery ground (–) lead first and reconnect it last. Make sure you connect the battery correctly. A direct short across the battery terminals can cause an explosion. Do not smoke while servicing batteries. Hydrogen gas given off during charging is very explosive.
- Keep a fire extinguisher available in or near the engine compartment and in other areas throughout the vessel. Use the correct extinguisher for the area. For most types of fires, an extinguisher rated ABC by the NFPA is available and suitable for use on all types of fires except alcohol.

EXHAUST GASES ARE DEADLY

- Provide adequate ventilation. Equip the bilge with a power exhauster.
- Be sure propulsion and generator set engine exhaust systems are free of leaks. Perform thorough, periodic inspections of the exhaust system and repair leaks immediately. Exhaust gases are deadly.
- Never sleep in the vessel with the generator set running unless the vessel is equipped with an operating carbon monoxide detector.

HOT COOLANT CAN CAUSE SEVERE PERSONAL INJURY

- Hot coolant is under pressure. Do not loosen the coolant pressure cap while the engine is hot. Let the engine cool before opening the pressure cap.

MOVING PARTS CAN CAUSE SEVERE PERSONAL INJURY OR DEATH

- Do not remove any belt guards or covers with the generator set running.
- Keep hands and loose clothing away from moving parts. Do not wear jewelry while servicing any part of the generator set.
- Never step on the generator set (as when entering or leaving the engine compartment). It can stress and break unit components, possibly resulting in dangerous operating conditions... from leaking fuel, leaking exhaust fumes, etc.
- Before performing any maintenance on the generator set, disconnect its batteries to prevent accidental starting. Do not disconnect or connect battery cables if fuel vapors are present. Ventilate the generator set compartment or bilge thoroughly with the power exhauster.

ELECTRICAL SHOCK WILL CAUSE SEVERE PERSONAL INJURY OR DEATH

- Do not make adjustments in the control panel or on engine with unit running. High voltages are present. Work that must be done while unit is running should be done only by qualified service personnel standing on dry surfaces to reduce shock hazard.
- DO NOT CONNECT THE GENERATOR SET TO THE PUBLIC UTILITY OR TO ANY OTHER ELECTRICAL POWER SYSTEM. Electrocutation or damage to property can occur at a site remote from the boat where line or equipment repairs are being made if the set is connected to the power system. An approved transfer switch must be used if more than one power source is to be made available to service the boat.
- Do not work on this equipment when mentally or physically fatigued, or after consuming any alcohol or drug that makes the operation of equipment unsafe.

M8

Copy and post these suggestions in potential hazard areas of the vessel.

Table of Contents

TITLE	PAGE
SAFETY PRECAUTIONS	Inside Front Cover
SECTION 1. INTRODUCTION	1-1
About This Manual	1-1
Test Equipment	1-1
How To Obtain Service	1-1
SECTION 2. AC CONTROL	2-1
Principle Of Generator Operation	2-1
Automatic Voltage Regulator	2-2
Automatic Voltage Regulator Adjustments	2-2
AC Meter Panel	2-5
SECTION 3. ENGINE CONTROL	3-1
General	3-1
Standard Control Components	3-1
Optional Control Components	3-1
Engine Sensor Locations	3-2
Sequence Of Operation	3-4
Electronic Governor	3-4
SECTION 4. TROUBLESHOOTING	4-1
Engine Does Not Crank	4-2
Engine Cranks But Does Not Start	4-3
Engine Runs Until Fault Shutdown	4-4
No Output Voltage At Stable Operating Speed (PMG-Excited Generators)	4-5
No Output Voltage At Stable Operating Speed (Self-Excited Generators)	4-6
Unstable Output Voltage At Stable Operating Speed	4-7
Output Voltage Too High Or Too Low	4-7
Field Circuit Breaker Keeps Tripping	4-8
Unbalanced Output Voltage	4-9
No Output Through Mounted Line Circuit Breaker	4-9
SECTION 5. GENERATOR SERVICE	5-1
Testing The Generator	5-1
Removing And Disassembling The Generator	5-5
Reassembling The Generator	5-7
Servicing The PMG	5-7
SECTION 6. MISCELLANEOUS	6-1
Heat Exchanger	6-1
Power Takeoff Unit	6-1
SECTION 7. WIRING DIAGRAMS	7-1

BUY NOW

**Then Instant Download
the Complete Manual
Thank you very much!**