

Workshop Manual

EH 4000ACII Rigid Dump Truck

Service Manual consists of the following separate Part No.
Technical Manual (Operational Principle) : Vol. No.TO8R7-E
Technical Manual (Troubleshooting) : Vol. No.TT8R7-E
Workshop Manual : Vol. No.W8R7-E

SAFETY

RECOGNIZE SAFETY INFORMATION

- These are the **SAFETY ALERT SYMBOLS**.
 - When you see these symbols on your machine or in this manual, be alert to the potential for personal injury.
 - Follow recommended precautions and safe operating practices.

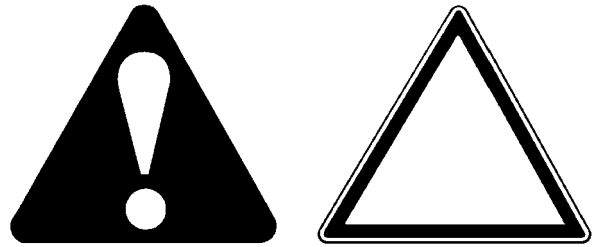

001-E01A-0001

SA-688

UNDERSTAND SIGNAL WORDS

- On machine safety signs, signal words designating the degree or level of hazard - **DANGER**, **WARNING**, or **CAUTION** - are used with the safety alert symbol.
 - **DANGER** indicates an imminently hazardous situation which, if not avoided, will result in death or serious injury.
 - **WARNING** indicates a potentially hazardous situation which, if not avoided, could result in death or serious injury.
 - **CAUTION** indicates a potentially hazardous situation which, if not avoided, may result in minor or moderate injury.
 - **DANGER** or **WARNING** safety signs are located near specific hazards. General precautions are listed on **CAUTION** safety signs.
 - Some safety signs don't use any of the designated signal words above after the safety alert symbol are occasionally used on this machine.



- To avoid confusing machine protection with personal safety messages, a signal word **IMPORTANT** indicates a situation which, if not avoided, could result in damage to the machine.
-  **NOTE** indicates an additional explanation for an element of information.

002-E01A-1223

SA-1223

SAFETY

FOLLOW SAFETY INSTRUCTIONS

- Carefully read and follow all safety signs on the machine and all safety messages in this manual.
- Safety signs should be installed, maintained and replaced when necessary.
 - If a safety sign or this manual is damaged or missing, order a replacement from your authorized dealer in the same way you order other replacement parts (be sure to state machine model and serial number when ordering).
- Learn how to operate the machine and its controls correctly and safely.
- Allow only trained, qualified, authorized personnel to operate the machine.
- Keep your machine in proper working condition.
 - Unauthorized modifications of the machine may impair its function and/or safety and affect machine life.
- The safety messages in this SAFETY chapter are intended to illustrate basic safety procedures of machines. However it is impossible for these safety messages to cover every hazardous situation you may encounter. If you have any questions, you should first consult your supervisor and/or your authorized dealer before operating or performing maintenance work on the machine.

003-E01B-0003

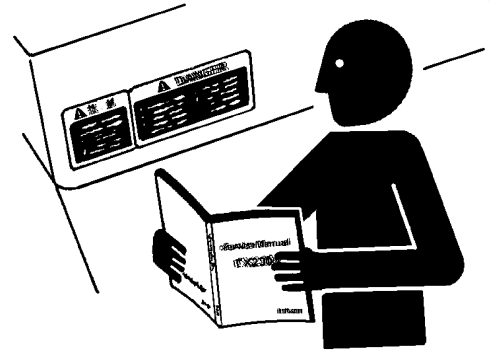

SA-003

PREPARE FOR EMERGENCIES

- Be prepared if a fire starts or if an accident occurs.
 - Keep a first aid kit and fire extinguisher on hand.
 - Thoroughly read and understand the label attached on the fire extinguisher to use it properly.
 - To ensure that a fire-extinguisher can be always used when necessary, check and service the fire-extinguisher at the recommended intervals as specified in the fire-extinguisher manual.
 - Establish emergency procedure guidelines to cope with fires and accidents.
 - Keep emergency numbers for doctors, ambulance service, hospital, and fire department posted near your telephone.



SA-437

004-E01A-0437

SAFETY

WEAR PROTECTIVE CLOTHING

- Wear close fitting clothing and safety equipment appropriate to the job.

You may need:

- A hard hat
- Safety shoes
- Safety glasses, goggles, or face shield
- Heavy gloves
- Hearing protection
- Reflective clothing
- Wet weather gear
- Respirator or filter mask.

Be sure to wear the correct equipment and clothing for the job. Do not take any chances.

- Avoid wearing loose clothing, jewelry, or other items that can catch on control levers or other parts of the machine.
- Operating equipment safely requires the full attention of the operator. Do not wear radio or music headphones while operating the machine.

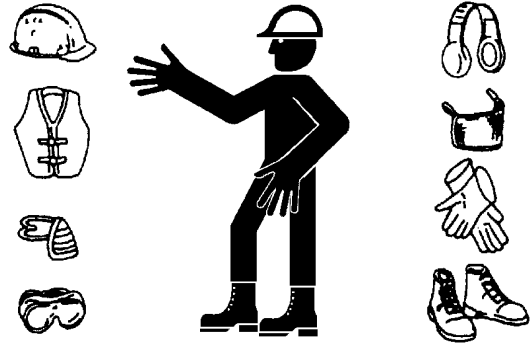

SA-438

005-E01A-0438

PROTECT AGAINST NOISE

- Prolonged exposure to loud noise can cause impairment or loss of hearing.
- Wear a suitable hearing protective device such as earmuffs or earplugs to protect against objectionable or uncomfortably loud noises.



006-E01A-0434

SA-434

INSPECT MACHINE

- Inspect your machine carefully each day or shift by walking around it before you start it to avoid personal injury.
- In the walk-around inspection, be sure to cover all points described in the "PRE-START INSPECTION" chapter in the operator's manual.



007-E01A-0435

SA-435

SECTION 1 GENERAL

— CONTENTS —

Group 1 Precautions for Disassembling and Assembling

Precautions for Disassembling and Assembling	W1-1-1
Maintenance Standard Terminology.....	W1-1-7

Group 2 Tightening

Tightening Torque Specifications	W1-2-1
Torque Chart.....	W1-2-2
Piping Joint.....	W1-2-5

Group 3 Periodic Replacement of Parts

Periodic Replacement of Parts	W1-3-1
-------------------------------------	--------

GENERAL / Precautions for Disassembling and Assembling

PRECAUTIONS FOR DISASSEMBLING AND ASSEMBLING

Precautions for Disassembling and Assembling

- Clean the Machine

Thoroughly wash the machine before bringing it into the shop. Bringing a dirty machine into the shop may cause machine components to be contaminated during disassembling/assembly, resulting in damage to machine components, as well as decreased efficiency in service work.

- Inspect the Machine

Be sure to thoroughly understand all disassembling / assembling procedures beforehand, to help avoid incorrect disassembling of components as well as personal injury.

Check and record the items listed below to prevent problems from occurring in the future.

- The machine model, machine serial number, and hour meter reading.
- Reason for disassembly (symptoms, failed parts, and causes).
- Clogging of filters and oil, water or air leaks, if any.
- Capacities and condition of lubricants.
- Loose or damaged parts.

- Prepare and Clean Tools and Disassembly Area

Prepare the necessary tools to be used and the area for disassembling work.

- Precautions for Disassembling

- To prevent dirt from entering, cap or plug the removed pipes.
- Before disassembling, clean the exterior of the components and place on a work bench.
- Before disassembling, drain gear oil from the wheel reduction device.
- Be sure to provide appropriate containers for draining fluids.
- Use matching marks for easier reassembly.
- Be sure to use the specified special tools, when instructed.
- If a part or component cannot be removed after removing its securing nuts and bolts, do not attempt to remove it forcibly. Find the cause(s), then take the appropriate measures to remove it.
- Orderly arrange disassembled parts. Mark and tag them as necessary.
- Store common parts, such as bolts and nuts with reference to where they are to be used and in a manner that will prevent loss.
- Inspect the contact or sliding surfaces of disassembled parts for abnormal wear, sticking, or other damage.
- Measure and record the degree of wear and clearances.

GENERAL / Precautions for Disassembling and Assembling

- Precautions for Assembling

- Be sure to clean all parts and inspect them for any damage. If any damage is found, repair or replace part.
- Dirt or debris on the contact or sliding surfaces may shorten the service life of the machine. Take care not to contaminate any contact or sliding surfaces.
- Be sure to replace O-rings, backup rings, and oil seals with new ones once they are disassembled. Apply a film of grease before installing.
- Be sure that liquid-gasket-applied surfaces are clean and dry.
- If an anti-corrosive agent has been used on a new part, be sure to thoroughly clean the part to remove the agent.
- Utilize matching marks when assembling.
- Be sure to use the designated tools to assemble bearings, bushings and oil seals.
- Keep a record of the number of tools used for disassembly/assembly. After assembling is complete, count the number of tools, so as to make sure that no forgotten tools remain in the assembled machine.

Bleeding Air from Hydraulic System

When hydraulic oil is drained, the suction filter or the suction lines are replaced, or the removal and installation of the pump, travel device cylinder is done, bleed air from the hydraulic system in the following procedures:

IMPORTANT: If the engine is started with air trapped in the hydraulic pump housing, damage to the pump may result. If the cylinder is operated with air trapped in the cylinder tube, damage to the cylinder may result. Be sure to bleed air before starting the engine.

- Bleeding Air from Hydraulic Pump

- Remove the air bleeding plug from the top of the pump and fill the pump housing with hydraulic oil.
- After the pump housing is filled with hydraulic oil, temporarily tighten the plug. Then, start the engine and run at slow idle speed.
- Slightly loosen the plug to bleed air from the pump housing until hydraulic oil oozes out.
- After bleeding all the air, securely tighten the plug.

- Bleeding Air from Front Brake, Rear Brake

- Set the wheel as the bleed valve of the brake head will be the highest location.
- Slightly loosen the plug to bleed air from the brake head.
- After bleeding all the air, securely tighten the plug.

GENERAL / Precautions for Disassembling and Assembling

- Bleeding Air from Hydraulic Circuit
 - After refilling hydraulic oil, start the engine. While operating hoist cylinder, steering cylinder evenly, operate the machine under light loads for 10 to 15 minutes. Slowly start each operation (never fully stroke the cylinders during initial operation stage). As the pilot oil circuit has an air bleed device, air trapped in the pilot oil circuit will be bled while performing the above operation for approx. 5 minutes.
 - Reposition the dump body to check hydraulic oil level.
 - Stop the engine. Recheck hydraulic oil level. Replenish oil as necessary.

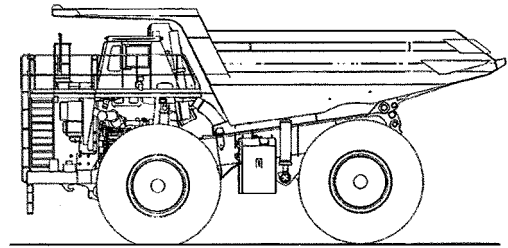

W8DS-03-04-001

GENERAL / Precautions for Disassembling and Assembling

Floating Seal Precautions

1. In general, replace the floating seal with a new one after disassembling. If the floating seal is to be reused, follow these procedures:

- (1) Keep seal rings together as a matched set with seal ring faces together. Insert a piece of cardboard to protect surfaces.
- (2) Check the slide surface on seal ring (A) for scuffing, scoring, corrosion, deformation or uneven wear.
- (3) Check O-ring (B) for tears, breaks, deformation or hardening.

2. If incorrectly assembled, oil leakage or damage will occur. Be sure to do the following, to prevent trouble.

- (1) Clean the floating seal and seal mounting bores with cleaning solvent. Use a wire brush to remove mud, rust or dirt. After cleaning, thoroughly dry parts with compressed air.
- (2) Clean the floating seal and seal mounting bores. Check the bore surface for scuffing or scoring by touching the surface with touch.
- (3) Check that the O-ring is not twisted, and that it is installed correctly on the seal ring.
- (4) After installing the floating seal, check that seal ring surface (A) is parallel with seal mating face (C) by measuring the distances (A) and (C) at point (a) and (b), as illustrated. If these distances differ, correct the O-ring seating.

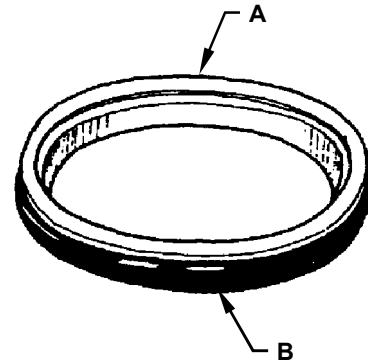

W105-03-05-019

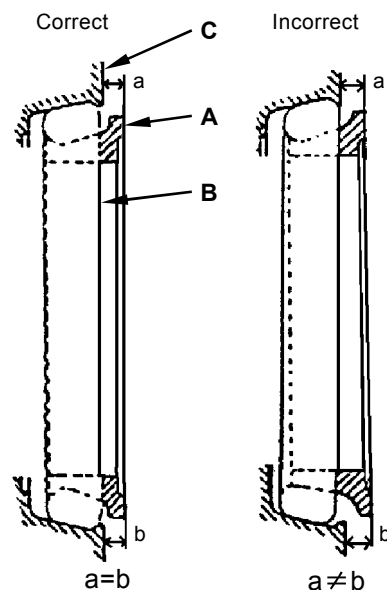
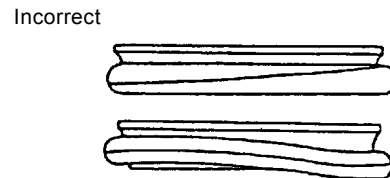
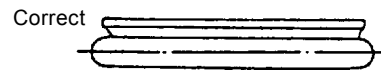
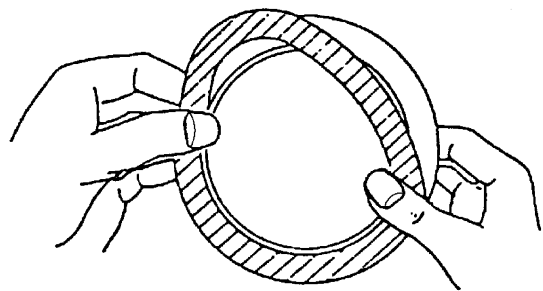

W105-03-05-020

W110-03-05-004

GENERAL / Precautions for Disassembling and Assembling

Precautions for Using Nylon Sling

1. Follow the precautions below to use nylon slings safely.
 - Attach protectors (soft material) on the corners of the load so that the nylon sling does not directly contact the corners. This will prevent the nylon sling from being damaged and the lifted load from slipping.
 - Lower the temperature of the lifted load to lower than 100 °C (212 °F). If unavoidably lifting a load with a temperature of 100 °C (212 °F) or more, reduce the load weight.
 - Do not lift acid or alkali chemicals.
 - Take care not to allow the sling to become wet. The load may slip.
 - When required to use more than one sling, use slings with the same width and length to keep the lifted load balanced.
 - When lifting a load using an eyehole, be sure to eliminate any gaps between the sling and load. (Refer to the right illustration.) Reduce the load weight so that it is less than 80 % of the sling breaking force.
 - Avoid using twisted, bound, connected, or hitched slings.
 - Do not place any object on twisted or bent slings. (Refer to the right illustration.)
 - When removing the slings from under the load, take care not to damage the nylon slings. Avoid contact with protrusions.
 - Avoid dragging slings on the ground, throwing slings or pushing slings with a metal object.
 - When using with other types of slings (wire rope) or accessories (shackle), protect the joint so that the nylon sling is not damaged.
 - Store the nylon slings indoors so they won't deteriorate with heat, sun light, or chemicals.

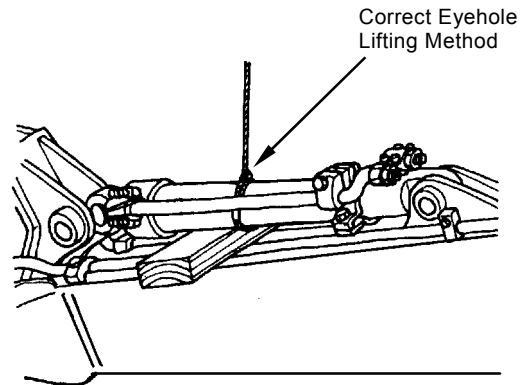

W102-04-02-016

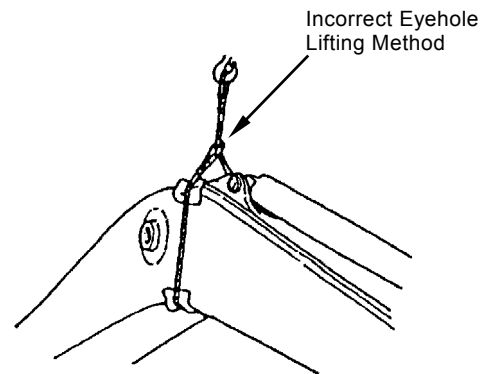

W105-04-01-008

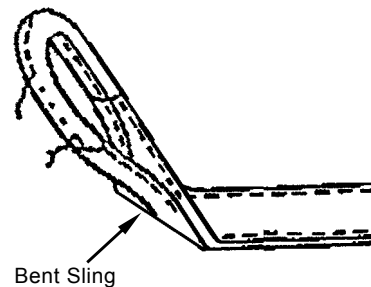

W162-01-01-009

GENERAL / Precautions for Disassembling and Assembling

! **CAUTION:** If a load is lifted with a damaged nylon sling, serious personal injury may result. Be sure to visually check the nylon sling for any damage before using.

2. Before using a nylon sling, visually check the nylon sling for any damage corresponding to examples shown to the right. If any damage is found, cut and discard the sling. Even if no damage is found, do not use slings older than 7-years.

Damaged Appearance

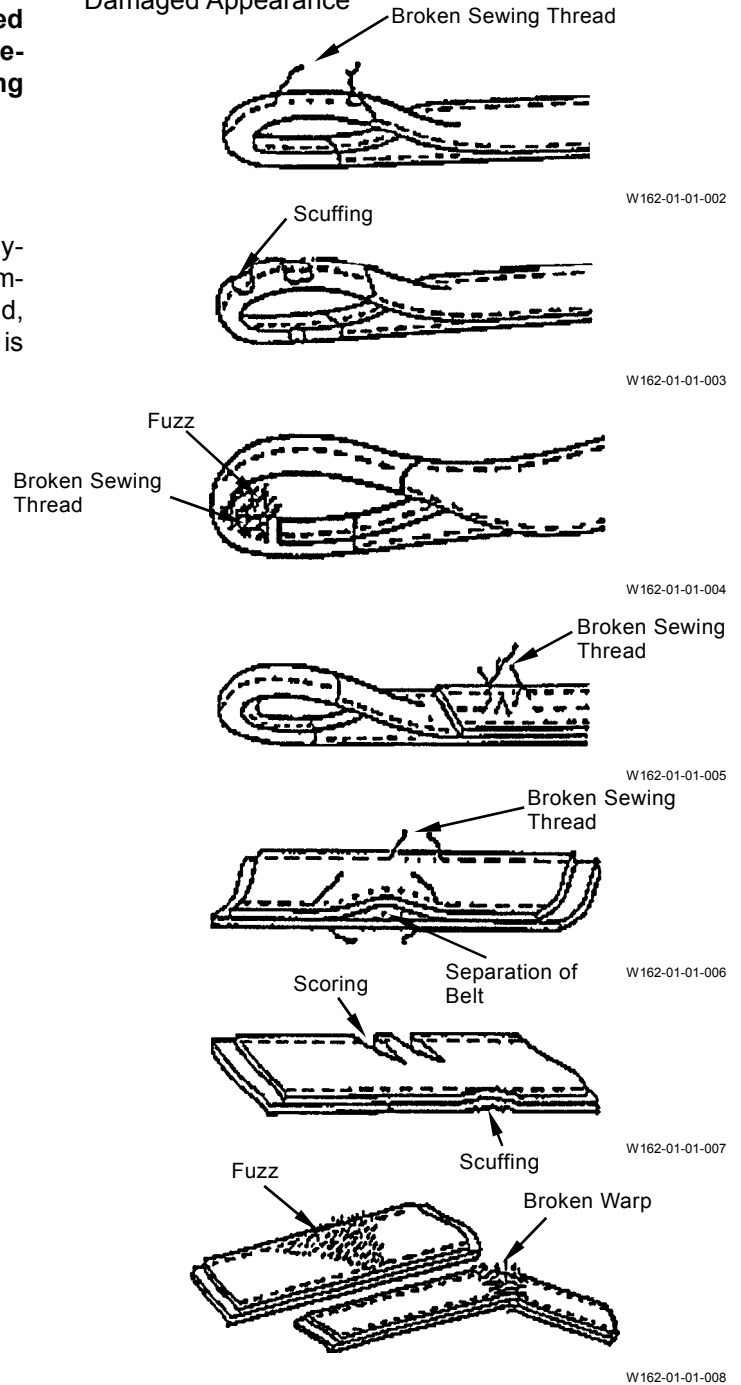

GENERAL / Precautions for Disassembling and Assembling

MAINTENANCE STANDARD TERMINOLOGY

“Standard”

1. Dimension for parts on a new machine.
2. Dimension of new components or assemblies adjusted to specification.

“Allowable Limit”

1. Normal machine performance cannot be accomplished after exceeding this limit.
2. Repair or adjustment is impossible after exceeding this limit.
3. Therefore, in consideration of operation efficiency and maintenance expense, proper maintenance shall be carried out before reaching the “Allowable Limit”.

SECTION 2

BODY

CONTENTS

Group 1 Cab

Removal and Installation of Cab	W2-1-1
Air Conditioner	W2-1-9

Group 2 Engine/Alternator

Removal and Installation of Engine	W2-2-1
Removal and Installation of Alternator ...	W2-2-21
Disassembly of Alternator	W2-2-28
Inspection	W2-2-38
Assembly of Alternator	W2-2-44

Group 3 Pump Device

Removal and Installation of Pump Device	W2-3-1
Disassembly of Main Pump	W2-3-8
Assembly of Main Pump	W2-3-14
Maintenance Standard	W2-3-18
Disassembly of Regulator for Main Pump	W2-3-20
Assembly of Regulator for Main Pump	W2-3-22
Structure of Gear Pump	W2-3-24
Disassembly of Drive Shaft	W2-3-26
Inspection of Drive Shaft	W2-3-30
Assembly of Drive Shaft	W2-3-34
Maintenance of Drive Shaft	W2-3-38

Group 4 Drive Device

Removal and Installation of Drive Device	W2-4-1
Removal and Installation of Wheel Motor Assembly	W2-4-10
Disassembly of Parking Brake	W2-4-14
Inspection of Parking Brake	W2-4-22
Assembly of Parking Brake	W2-4-24
Procedures for the 500-Hour Maintenance Inspection	W2-4-34

Removal and Installation of Wheel Motor Assembly	W2-4-36
Disassembly of Wheel Motor	W2-4-44
Inspection of Wheel Motor	W2-4-52
Assembly of Wheel Motor	W2-4-54
Disassembly of Wheel Reduction Device	W2-4-66
Assembly of Wheel Reduction Device	W2-4-93
Disassembly of First Stage Carrier Assembly	W2-4-132
Assembly of First Stage Carrier Assembly	W2-4-136
Disassembly of Second Stage Carrier Assembly	W2-4-144
Assembly of Second Stage Carrier Assembly	W2-4-148
Disassembly of Brake Assembly	W2-4-156
Assembly of Brake Assembly	W2-4-160
Wheel Bearing Preload Operation Management Procedures	W2-4-166
Brake Clearance Adjustment Procedure	W2-4-178
Friction Disc Wear Measurement Procedure	W2-4-180
Break-in Operation of Wheel Reduction Device	W2-4-182

Group 5 Front Axle

Front Axle	W2-5-1
Inspecting Front Axle Assembly Play	W2-5-4
Removal and Installation of Spindle Assembly	W2-5-6
Removal and Installation of Trailing Arm	W2-5-18
Front Wheel Adjustment	W2-5-30
Removal and Installation of Front Wheel	W2-5-34

Group 6 Tire and Rim

Tire / Rim / Air Pressure	W2-6-1
Removal and Installation of Front Tire and Rim	W2-6-2
Removal and Installation of Rear Tire and Rim	W2-6-6
Tire Care	W2-6-12
Tire Air Pressure Inspection.....	W2-6-12

Group 7 Front Brake

Removal and Installation of Front Brake.....	W2-7-1
Disassembly of Brake Head	W2-7-6
Inspection of Brake Head and Brake Disc	W2-7-8
Assembly of Brake Head	W2-7-10
Removal and Installation of Lining.....	W2-7-14
Air Bleeding of Front Brake	W2-7-20

Group 8 Brake Valve

Removal and Installation of Brake Valve	W2-8-1
Disassembly of Brake Valve	W2-8-6
Inspection of Brake Valve	W2-8-12
Assembly of Brake Valve	W2-8-14
Replacement of Brake Cartridge Seal	W2-8-20

Group 9 Brake Accumulator

Removal and Installation of Rear Brake Accumulator.....	W2-9-1
Removal and Installation of Front Brake Accumulator	W2-9-3
Disassembly of Brake Accumulator	W2-9-6
Assembly of Brake Accumulator	W2-9-8
Charging Nitrogen Gas.....	W2-9-12

Group 10 Steering System

Removal and Installation of Steering Column Assembly.....	W2-10-1
Disassembly and Assembly of Driveshaft	W2-10-7
Disassembly and Assembly of Steering Column	W2-10-7
Disassembly, Assembly and Inspection of Steering Valve.....	W2-10-8

Removal and Installation of Flow Amplifier	W2-10-10
Disassembly and Assembly of Flow Amplifier	W2-10-15
Removal and Installation of Steering Cylinder	W2-10-16
Disassembly of Steering Cylinder	W2-10-20
Inspection of Steering Cylinder	W2-10-24
Assembly of Steering Cylinder	W2-10-26
Test of Steering Cylinder	W2-10-32
Removal and Installation of Main Accumulator	W2-10-34
Disassembly of Main Accumulator	W2-10-38
Assembly of Main Accumulator	W2-10-40
Charging Nitrogen Gas	W2-10-44

Group 11 Frame Suspension

Removal and Installation of Front Suspension Cylinder	W2-11-1
Disassembly of Front Suspension Cylinder	W2-11-6
Inspection of Front Suspension Cylinder	W2-11-8
Assembly of Front Suspension Cylinder	W2-11-10
Charging Neocon Oil	W2-11-14
Charging Helium Gas	W2-11-16
Servicing Procedure of Front Suspension Cylinder	W2-11-19
Suspension Cylinder Storage	W2-11-19
Removal and Installation of Rear Suspension Cylinder	W2-11-20
Disassembly of Rear Suspension Cylinder	W2-11-26
Inspection of Rear Suspension Cylinder	W2-11-28
Assembly of Rear Suspension Cylinder	W2-11-30
Charging Neocon Oil	W2-11-34
Charging Helium Gas	W2-11-36
Servicing Procedure of Rear Suspension Cylinder	W2-11-39
Suspension Cylinder Storage	W2-11-39

BODY / Cab

REMOVAL AND INSTALLATION OF CAB

Removal

1. Park the machine in the service position on a level surface.
2. Raise the dump body. Insert the body prop pins to prevent the dump body from lowering.
3. Remove bolts (2) (5 used), washers (3) (5 used) from the right side of cab (1). Remove cover (4).
 : 17 mm
4. Disconnect connectors of the electronic control system wired in the cab.

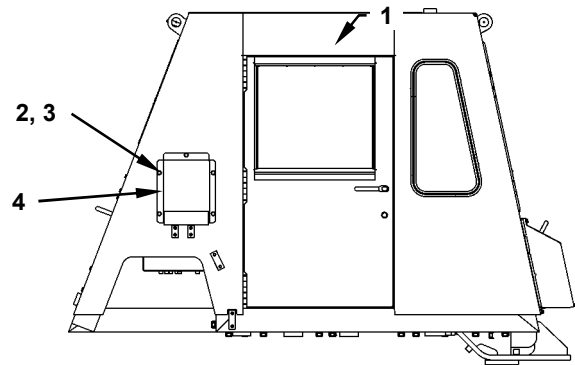



Right side of cab (1)

W8R7-02-01-001

 **CAUTION: Before disconnecting the brake accumulator piping, release the oil pressure in the brake system.**

5. Release the oil pressure from the brake system. Refer to REMOVAL AND INSTALLATION OF BRAKE VALVE.

 **CAUTION: Floor cover (7) weight: 28 kg (62 lb)**

6. Remove bolts (5) (4 used), washers (6) (4 used). Remove floor cover (7) from the right side of cab.
 : 19 mm
7. Disconnect hydraulic hoses from piping (8) and (9) of the brake accumulator piping in cab (1). Mark the identification number to the disconnected hydraulic hoses. Cap the disconnected hydraulic hoses.
 : 22 mm
8. Remove bolts (10) (8 used) and washers (11) (8 used) from cab (1). Remove clamp bracket (12), and clamp brackets (13) (3 used) with manual body down valve pipings.

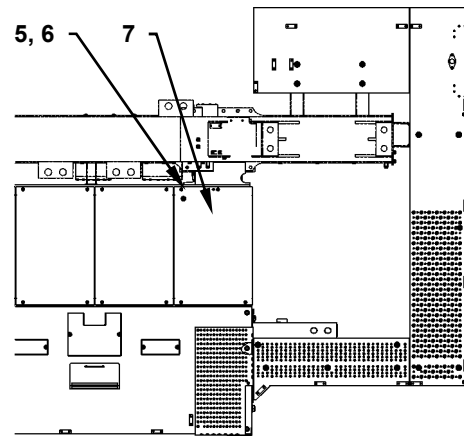

W8R7-02-01-002

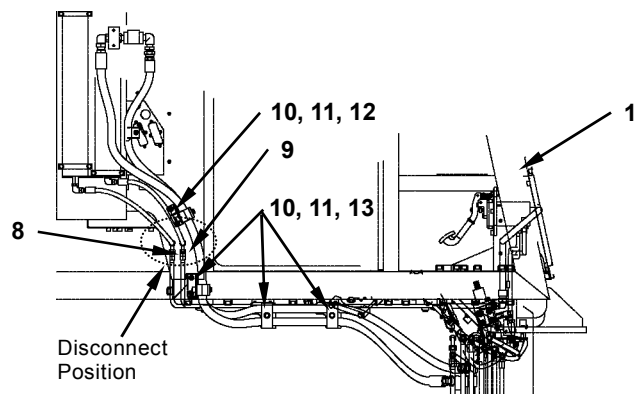

W8R7-02-01-003

BUY NOW

**Then Instant Download
the Complete Manual
Thank you very much!**