

Workshop Manual

EX 8000-6 Hydraulic Excavator

Service Manual consists of the following separate Part No.
Technical Manual (Operational Principle) : Vol. No.TO18P-E
Technical Manual (Troubleshooting) : Vol. No.TT18P-E
Workshop Manual : Vol. No.W18P-E

SAFETY

RECOGNIZE SAFETY INFORMATION

- These are the **SAFETY ALERT SYMBOLS**.
 - When you see these symbols on your machine or in this manual, be alert to the potential for personal injury.
 - Follow recommended precautions and safe operating practices.

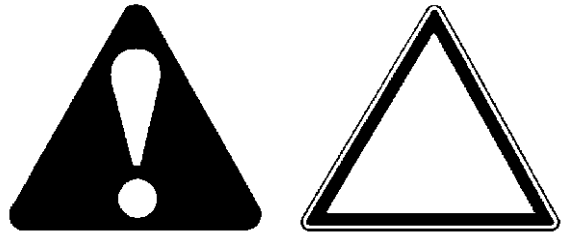

SA-688

UNDERSTAND SIGNAL WORDS

- On machine safety signs, signal words designating the degree or level of hazard - **DANGER**, **WARNING**, or **CAUTION** - are used with the safety alert symbol.
 - **DANGER** indicates an imminently hazardous situation which, if not avoided, will result in death or serious injury.
 - **WARNING** indicates a potentially hazardous situation which, if not avoided, could result in death or serious injury.
 - **CAUTION** indicates a potentially hazardous situation which, if not avoided, may result in minor or moderate injury.
 - **DANGER** or **WARNING** safety signs are located near specific hazards. General precautions are listed on **CAUTION** safety signs.
 - Some safety signs don't use any of the designated signal words above after the safety alert symbol are occasionally used on this machine.



IMPORTANT



SA-1223

- To avoid confusing machine protection with personal safety messages, a signal word **IMPORTANT** indicates a situation which, if not avoided, could result in damage to the machine.
-  **NOTE** indicates an additional explanation for an element of information.

SAFETY

FOLLOW SAFETY INSTRUCTIONS

- Carefully read and follow all safety signs on the machine and all safety messages in this manual.
- Safety signs should be installed, maintained and replaced when necessary.
 - If a safety sign or this manual is damaged or missing, order a replacement from your authorized dealer in the same way you order other replacement parts (be sure to state machine model and serial number when ordering).
- Learn how to operate the machine and its controls correctly and safely.
- Allow only trained, qualified, authorized personnel to operate the machine.
- Keep your machine in proper working condition.
 - Unauthorized modifications of the machine may impair its function and/or safety and affect machine life.
 - Do not modify any machine parts without authorization. Failure to do so may deteriorate the part safety, function, and/or service life. In addition, personal accident, machine trouble, and/or damage to material caused by unauthorized modifications will void Hitachi Warranty Policy.
 - Do not use attachments and/or optional parts or equipment not authorized by Hitachi. Failure to do so may deteriorate the safety, function, and/or service life of the machine. In addition, personal accident, machine trouble, and/or damage to material caused by using unauthorized attachments and/or optional parts or equipment will void Hitachi Warranty Policy.
- The safety messages in this SAFETY chapter are intended to illustrate basic safety procedures of machines. However it is impossible for these safety messages to cover every hazardous situation you may encounter. If you have any questions, you should first consult your supervisor and/or your authorized dealer before operating or performing maintenance work on the machine.

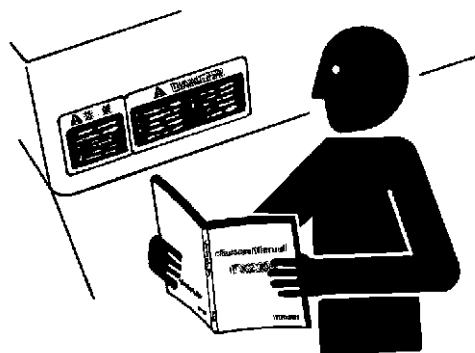

SA-003

003-E01B-0003

PREPARE FOR EMERGENCIES

- Be prepared if a fire starts or if an accident occurs.
 - Keep a first aid kit and fire extinguisher on hand.
 - Thoroughly read and understand the label attached on the fire extinguisher to use it properly.
 - To ensure that a fire-extinguisher can be always used when necessary, check and service the fire-extinguisher at the recommended intervals as specified in the fire-extinguisher manual.
 - Establish emergency procedure guidelines to cope with fires and accidents.
 - Keep emergency numbers for doctors, ambulance service, hospital, and fire department posted near your telephone.

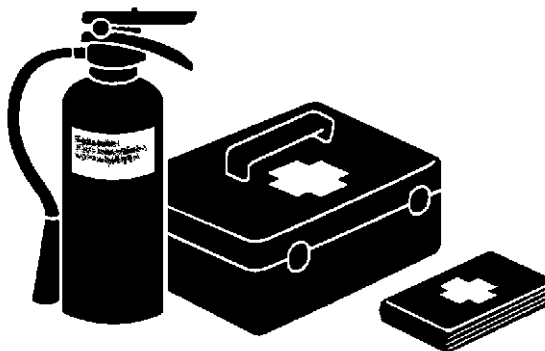

SA-437

004-E01A-0437

SAFETY

WEAR PROTECTIVE CLOTHING

- Wear close fitting clothing and safety equipment appropriate to the job.

You may need:

- A hard hat
- Safety shoes
- Safety glasses, goggles, or face shield
- Heavy gloves
- Hearing protection
- Reflective clothing
- Wet weather gear
- Respirator or filter mask.

Be sure to wear the correct equipment and clothing for the job. Do not take any chances.

- Avoid wearing loose clothing, jewelry, or other items that can catch on control levers or other parts of the machine.
- Operating equipment safely requires the full attention of the operator. Do not wear radio or music headphones while operating the machine.

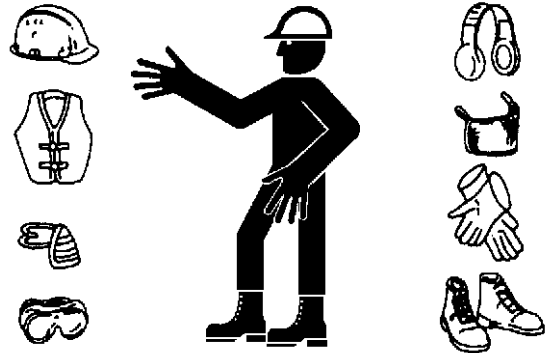

SA-438

005-E01A-0438

PROTECT AGAINST NOISE

- Prolonged exposure to loud noise can cause impairment or loss of hearing.
- Wear a suitable hearing protective device such as earmuffs or earplugs to protect against objectionable or uncomfortably loud noises.



006-E01A-0434

SA-434

INSPECT MACHINE

- Inspect your machine carefully each day or shift by walking around it before you start it to avoid personal injury.
- In the walk-around inspection, be sure to cover all points described in the “PRE-START INSPECTION” chapter in the operator’s manual.



007-E01A-0435

SA-435

SAFETY

GENERAL PRECAUTIONS FOR CAB

- Before entering the cab, thoroughly remove all dirt and/or oil from the soles of your work boots. If any controls such as a pedal is operated while with dirt and/or oil on the soles of the operator's work boots the operator's foot may slip off the pedal, possibly resulting in a personal accident.
- Do not leave parts and/or tools lying around the operator's seat. Store them in their specified locations.
- Avoid storing transparent bottles in the cab. Do not attach any transparent type window decorations on the windowpanes as they may focus sunlight, possibly starting a fire.
- Refrain from listening to the radio, or using music headphones or mobile telephones in the cab while operating the machine.
- Keep all flammable objects and/or explosives away from the machine.
- After using the ashtray, always cover it to extinguish the match and/or tobacco.
- Do not leave cigarette lighters in the cab. When the temperature in the cab increases, the lighter may explode.

524-E01A-0000

**SECTION AND GROUP
CONTENTS**

WORKSHOP MANUAL

SECTION 1 GENERAL

Group 1 Precautions for Disassembling and Assembling
Group 2 Tightening
Group 3 Bleeding Air from Hydraulic Oil Tank

SECTION 2 UPPERSTRUCTURE

Group 1 Cab
Group 2 Counterweight
Group 3 Pump Device
Group 4 Control Valve
Group 5 Swing Device
Group 6 DQR Valve
Group 7 Fan Drive Motor
Group 8 Solenoid Valve
Group 9 Shuttle Valve
Group 10 Block Valve with Folding Stairway
Group 11 Compressor Drive Motor
Group 12 Air Conditioner
Group 13 Lift Cylinder
Group 14 Arm Extend Priority Valve

SECTION 3 UNDERCARRIAGE

Group 1 Swing Bearing
Group 2 Travel Device
Group 3 Travel Brake Valve
Group 4 Drive Tumbler
Group 5 Center Joint
Group 6 Adjuster Cylinder
Group 7 Front Idler
Group 8 Upper and Lower Roller
Group 9 Track
Group 10 Accumulator
Group 11 Welding Repair Procedure

SECTION 4 FRONT ATTACHMENT

Group 1 Front Attachment
Group 2 Cylinder
Group 3 Bushing and Point
Group 4 Angle Indicator
Group 5 Solenoid Valve
Group 6 Valve

TECHNICAL MANUAL (Operational Principle)

SECTION 1 GENERAL

- Group 1 Specifications
- Group 2 Component Specifications
- Group 3 Component Layout

SECTION 2 SYSTEM

- Group 1 Controller
- Group 2 Control System
- Group 3 ELU System
- Group 4 Hydraulic System
- Group 5 Electrical System

SECTION 3 COMPONENT OPERATION

- Group 1 Pump Device
- Group 2 Swing Device
- Group 3 Control Valve
- Group 4 Control Equipment
- Group 5 DQR Valve
- Group 6 Travel Device
- Group 7 Others(Upperstructure)
- Group 8 Others(Undercarriage)

TECHNICAL MANUAL (Troubleshooting)

SECTION 4 OPERATIONAL PERFORMANCE TEST

- Group 1 Introduction
- Group 2 Standard
- Group 3 Engine Test
- Group 4 Excavator Test
- Group 5 Component Test

SECTION 5 TROUBLESHOOTING

- Group 1 Diagnosing Procedure
 - Group 2 Component Layout
 - Group 3 Troubleshooting A
 - Group 4 Troubleshooting B
 - Group 5 Troubleshooting C
 - Group 6 Electrical System Inspection
-

SECTION 1 GENERAL



CONTENTS

Group 1 Precautions for Disassembling and Assembling

Precautions for Disassembling and Assembling	W1-1-1
Maintenance Standard Terminology.....	W1-1-7

Group 2 Tightening

Tightening Torque Specification	W1-2-1
Torque Chart.....	W1-2-3
Piping Joint.....	W1-2-6
Periodic Replacement of Parts	W1-2-10

Group 3 Bleed Air from Hydraulic Oil Tank

Bleed Air from Hydraulic Oil Tank	W1-3-1
-----------------------------------------	--------

GENERAL / Precautions for Disassembling and Assembling

PRECAUTIONS FOR DISASSEMBLING AND ASSEMBLING

Precautions for Disassembling and Assembling

- Clean the Machine

Thoroughly wash the machine before bringing it into the shop. Bringing a dirty machine into the shop may cause machine components to be contaminated during disassembling/assembling, resulting in damage to machine components, as well as decreased efficiency in service work.

- Inspect the Machine

Be sure to thoroughly understand all disassembling/assembling procedures beforehand, to help avoid incorrect disassembling of components as well as personal injury. Check and record the items listed below to prevent problems from occurring in the future.

- The machine model, machine serial number, and hour meter reading.
- Reason for disassembly (symptoms, failed parts, and causes).
- Clogging of filters and oil, water or air leaks, if any.
- Capacities and condition of lubricants.
- Loose or damaged parts.

- Prepare and Clean Tools and Disassembly Area

Prepare the necessary tools to be used and the area for disassembling work.

- Precautions for Disassembling

- To prevent dirt from entering, cap or plug the removed pipes.
- Before disassembling, clean the exterior of the components and place on a work bench.
- Before disassembling, drain gear oil from the reduction gear.
- Be sure to provide appropriate containers for draining fluids.
- Use matching marks for easier reassembling.
- Be sure to use the specified special tools, when instructed.
- If a part or component cannot be removed after removing its securing nuts and bolts, do not attempt to remove it forcibly. Find the cause(s), then take the appropriate measures to remove it.
- Orderly arrange disassembled parts. Mark and tag them as necessary.
- Store common parts, such as bolts and nuts with reference to where they are to be used and in a manner that will prevent loss.
- Inspect the contact or sliding surfaces of disassembled parts for abnormal wear, sticking, or other damage.
- Measure and record the degree of wear and clearances.

GENERAL / Precautions for Disassembling and Assembling

- Precautions for Assembling

- Be sure to clean all parts and inspect them for any damage. If any damage is found, repair or replace part.
- Dirt or debris on the contact or sliding surfaces may shorten the service life of the machine. Take care not to contaminate any contact or sliding surfaces.
- Be sure to replace O-rings, backup rings, and oil seals with new ones once they are disassembled. Apply a film of grease before installing.
- Be sure that liquid-gasket-applied surfaces are clean and dry.
- If an anti-corrosive agent has been used on a new part, be sure to thoroughly clean the part to remove the agent.
- Utilize matching marks when assembling.
- Be sure to use the designated tools to assemble bearings, bushings and oil seals.
- Keep a record of the number of tools used for disassembly/assembly. After assembling is complete, count the number of tools, so as to make sure that no forgotten tools remain in the assembled machine.

Bleeding Air from Hydraulic System

When hydraulic oil is drained, the suction filter or the suction lines are replaced, or the removal and installation of the pump, swing motor, travel motor or cylinder is done, bleed air from the hydraulic system in the following procedures:

IMPORTANT: If the engine is started with air trapped in the hydraulic pump housing, damage to the pump may result. If the hydraulic motor is operated with air trapped in the hydraulic motor housing, damage to the motor may result. If the cylinder is operated with air trapped in the cylinder tube, damage to the cylinder may result. Be sure to bleed air before starting the engine.

- Bleeding Air from Hydraulic Pump

- Remove the air bleeding plug from the top of the pump and fill the pump housing with hydraulic oil.
- After the pump housing is filled with hydraulic oil, temporarily tighten the plug. Then, start the engine and run at slow idle speed.
- Slightly loosen the plug to bleed air from the pump housing until hydraulic oil oozes out.
- After bleeding all the air, securely tighten the plug.

- Bleeding Air from Travel Motor / Swing Motor

- With the drain plug / hose on travel motor / swing motor removed, fill the motor case with hydraulic oil.

GENERAL / Precautions for Disassembling and Assembling

- Bleeding Air from Hydraulic Circuit
 - After refilling hydraulic oil, start the engine. While operating each cylinder, swing motor and travel motor evenly, operate the machine under light loads for 10 to 15 minutes. Slowly start each operation (never fully stroke the cylinders during initial operation stage). As the pilot oil circuit has an air bleed device, air trapped in the pilot oil circuit will be bled while performing the above operation for approx. 5 minutes.
 - Reposition the front attachment to check hydraulic oil level.
 - Stop the engine. Recheck hydraulic oil level. Replenish oil as necessary.

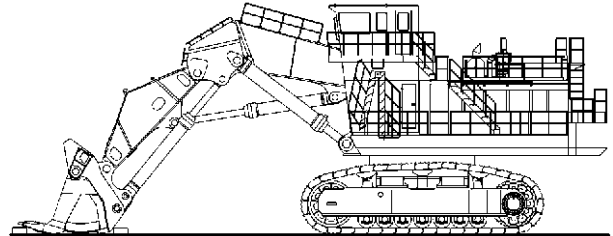

W18G-01-01-001

GENERAL / Precautions for Disassembling and Assembling

Floating Seal Precautions

1. In general, replace the floating seal with a new one after disassembling. If the floating seal is to be reused, follow these procedures:

- (1) Keep seal rings together as a matched set with seal ring faces together. Insert a piece of cardboard to protect surfaces.
- (2) Check the slide surface on seal ring (A) for scuffing, scoring, corrosion, deformation or uneven wear.
- (3) Check O-ring (B) for tears, breaks, deformation or hardening.

2. If incorrectly assembled, oil leakage or damage will occur. Be sure to do the following, to prevent trouble.

- (1) Clean the floating seal and seal mounting bores with cleaning solvent. Use a wire brush to remove mud, rust or dirt. After cleaning, thoroughly dry parts with compressed air.
- (2) Clean the floating seal and seal mounting bores. Check the bore surface for scuffing or scoring by touching the surface with touch.
- (3) Check that the O-ring is not twisted, and that it is installed correctly on the seal ring.
- (4) After installing the floating seal, check that seal ring surface (A) is parallel with seal mating face (C) by measuring the distances (A) and (C) at point (a) and (b), as illustrated. If these distances differ, correct the O-ring seating.

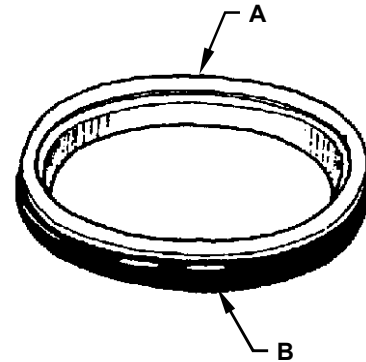

W105-03-05-019

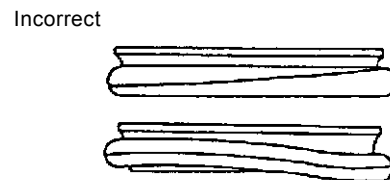
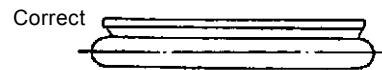
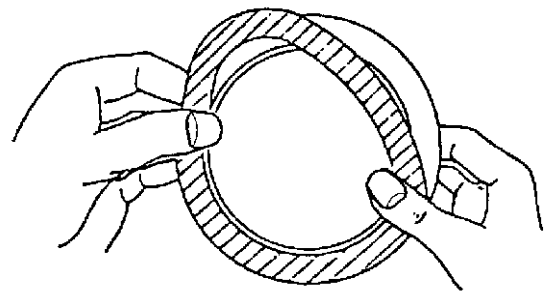

W105-03-05-020

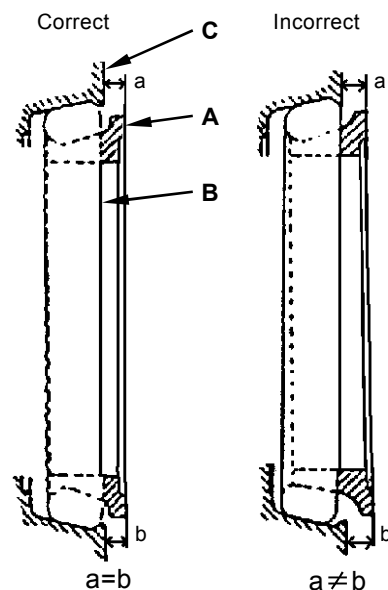

W110-03-05-004

GENERAL / Precautions for Disassembling and Assembling

Precautions for Using Nylon Sling

1. Follow the precautions below to use nylon slings safely.
 - Attach protectors (soft material) on the corners of the load so that the nylon sling does not directly contact the corners. This will prevent the nylon sling from being damaged and the lifted load from slipping.
 - Lower the temperature of the lifted load to lower than 100 °C (212 °F). If unavoidably lifting a load with a temperature of 100 °C (212 °F) or more, reduce the load weight.
 - Do not lift acid or alkali chemicals.
 - Take care not to allow the sling to become wet. The load may slip.
 - When required to use more than one sling, use slings with the same width and length to keep the lifted load balanced.
 - When lifting a load using an eyehole, be sure to eliminate any gaps between the sling and load. (Refer to the right illustration.) Reduce the load weight so that it is less than 80 % of the sling breaking force.
 - Avoid using twisted, bound, connected, or hitched slings.
 - Do not place any object on twisted or bent slings. (Refer to the right illustration.)
 - When removing the slings from under the load, take care not to damage the nylon slings. Avoid contact with protrusions.
 - Avoid dragging slings on the ground, throwing slings or pushing slings with a metal object.
 - When using with other types of slings (wire rope) or accessories (shackle), protect the joint so that the nylon sling is not damaged.
 - Store the nylon slings indoors so they won't deteriorate with heat, sun light, or chemicals.

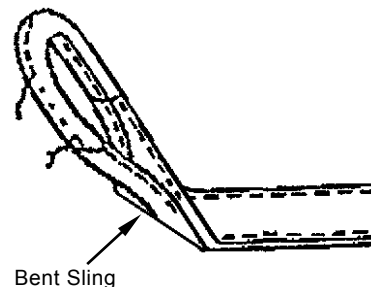

W162-01-01-009

GENERAL / Precautions for Disassembling and Assembling

CAUTION: If a load is lifted with a damaged nylon sling, serious personal injury may result. Be sure to visually check the nylon sling for any damage before using.

2. Before using a nylon sling, visually check the nylon sling for any damage corresponding to examples shown to the right. If any damage is found, cut and discard the sling. Even if no damage is found, do not use slings older than 7-years.

Damaged Appearance

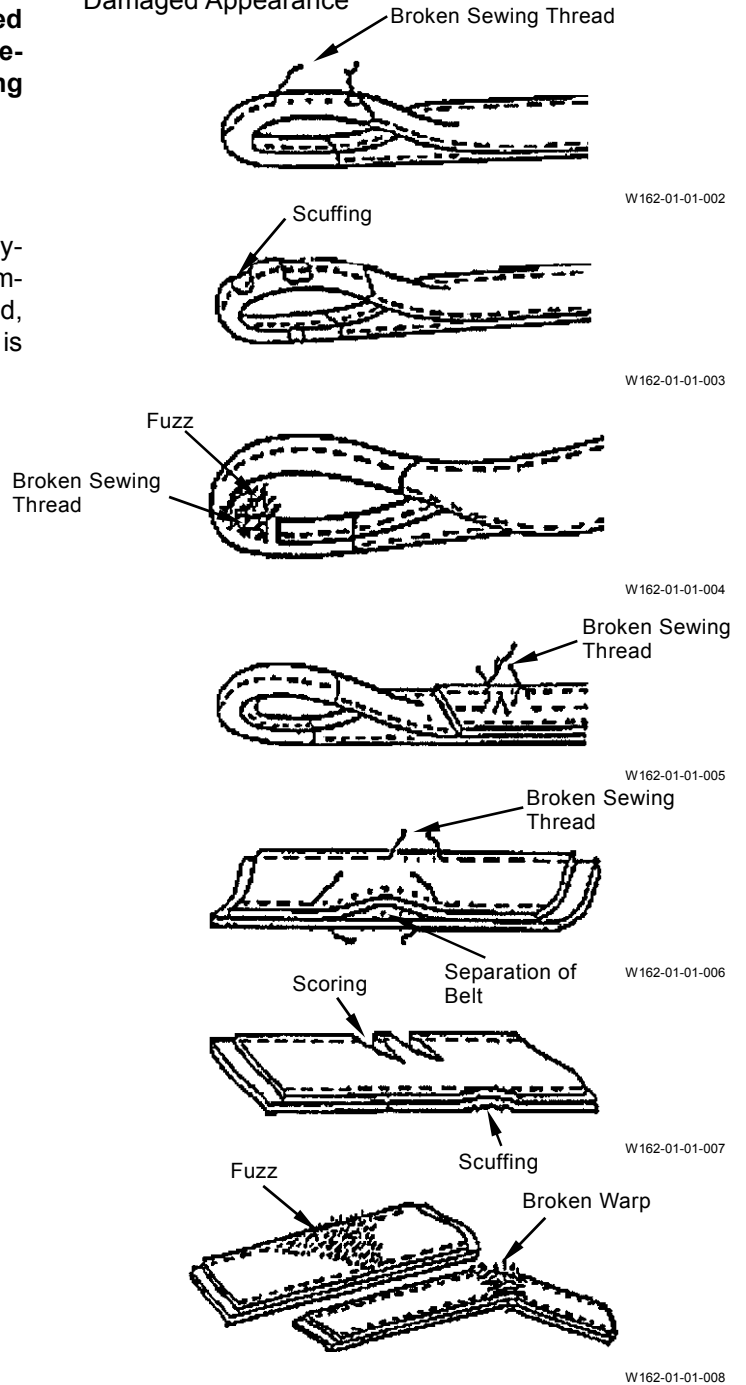

GENERAL / Precautions for Disassembling and Assembling

MAINTENANCE STANDARD TERMINOLOGY

“Standard”

1. Dimension for parts on a new machine.
2. Dimension of new components or assemblies adjusted to specification.

“Allowable Limit”

1. Normal machine performance cannot be accomplished after exceeding this limit.
2. Repair or adjustment is impossible after exceeding this limit.
3. Therefore, in consideration of operation efficiency and maintenance expense, proper maintenance shall be carried out before reaching the “Allowable Limit”.

GENERAL / Tightening

TIGHTENING TORQUE SPECIFICATION

No.	Descriptions	Bolt Dia (mm)	Q'ty	Wrench Size (mm)	Torque			
					N·m	(kgf·m)	(lbf·ft)	
1	Engine cushion rubber mounting bolt	36	20	55	3200	(320)	(2360)	
2	Engine bracket mounting bolt	a	33	32	50	1950	(195)	(1440)
		b	20	64	30	550	(55)	(410)
		c	22	12	32	750	(75)	(550)
3	Pump transmission mounting bolt	12	32	19	110	(11)	(81)	
4	Pump mounting bolt (Main pump)	24	32	36	950	(95)	(700)	
	Pump mounting bolt (Fan pump)	20	8	30	550	(55)	(410)	
5	Gear pump mounting bolt	14	14	22	140	(14)	(103)	
6	Hydraulic oil tank mounting bolt	36	18	55	3200	(320)	(2360)	
7	Fuel tank mounting bolt	36	30	55	3200	(320)	(2360)	
8	Control valve mounting bolt	20	24	30	400	(40)	(295)	
9	Swing device mounting bolt (A)	36	72	55	3200	(320)	(2360)	
	Swing device mounting bolt (B)	24	144	36	950	(95)	(700)	
10	Swing motor mounting bolt	20	24	30	400	(40)	(295)	
11	Cab mounting bolt	18	17	27	300	(30)	(220)	
12	Cab cushion rubber mounting bolt	12	68	19	110	(11)	(81)	
13	Cab bed spacer mounting bolt	14	52	22	180	(18)	(135)	
14	Cab bed mounting bolt	14	52	22	180	(18)	(135)	
15	Battery mounting bolt	10	32	17	20	(2.0)	(15.0)	
16	Folding stairway mounting bolt	20	12	30	550	(55)	(410)	
17	Radiator mounting bolt	27	16	41	1400	(140)	(1030)	
18	Oil cooler mounting bolt	27	12	41	1400	(140)	(1030)	
19	Engine bed mounting bolt	42	78	65	5100	(510)	(3760)	
20	Swing bearing mounting bolt (Upperstructure)	56	68	85	9800	(980)	(7230)	
	Swing bearing mounting bolt (Track)	56	94	85	9800	(980)	(7230)	
21	Counterweight mounting bolt (Main weight)	56	20	85	6900	(690)	(5060)	
	Counterweight mounting bolt (Sub weight)	56	8	85	6900	(690)	(5060)	
22	Travel device mounting bolt (A)	42	24	65	5100	(510)	(3760)	
	Travel device mounting bolt (B)	64	64	95	13000	(1300)	(9410)	
	Travel device mounting bolt (C)	24	48	36	700	(70)	(520)	
	Travel device mounting bolt (D)	20	50	30	400	(40)	(295)	
23	Travel motor mounting bolt	22	16	32	750	(75)	(550)	
24	Upper roller mounting bolt	32	24	56	3200	(320)	(2360)	
	Upper slider mounting bolt (Optional)	39	24	60	3900	(390)	(2880)	
25	Lower roller mounting bolt	64	56	95	13000	(1300)	(9410)	
26	Track pin-retaining bolt	30	156	46	1950	(195)	(1440)	
27	Side frame mounting bolt	72	84	105	18000	(1800)	(13030)	
28	Front pin-retaining bolt (A)	24	12	36	950	(95)	(700)	
	Front pin-retaining bolt (B)	24	28	36	950	(95)	(700)	
	Front pin-retaining bolt (C)	20	8	30	550	(55)	(410)	
	Front pin-retaining bolt (D)	20	72	30	550	(55)	(410)	
	Front pin-retaining bolt (E)	27	12	19★	1050	(105)	(770)	
29	Valve block mounting bolt (on the boom)	24	8	36	950	(95)	(700)	
	Valve block mounting bolt (under the boom)	20	4	36	950	(95)	(700)	

 NOTE: ★: Hexagonal socket wrench.
Tightening Torque Chart

GENERAL / Tightening

-  NOTE 1. Apply lubricant (e.g. white zinc B dissolved into spindle oil) to bolts and nuts to reduce friction coefficient of them.
2. Make sure bolt and nut threads are clean before installing.

GENERAL / Tightening

TORQUE CHART









CAUTION: Use tools appropriate for the work to be done. Makeshift tools and procedures can create safety hazards. For loosening and tightening nuts and bolts, use correct size tools. Otherwise, tightening tools may slip, potentially causing personal injury.



Bolt Types

Tighten nuts or bolts correctly to torque specifications. Four different types and grades of bolt are employed. Make sure to employ correct bolts and tighten them correctly when assembling the machine or components.

SA-040

Bolt Dia.	Wrench Size	Hexagon Wrench Size	   M552-07-091 Socket Bolt			   M552-07-090			 M552-07-092		
			N-m	(kgf-m)	(lbf-ft)	N-m	(kgf-m)	(lbf-ft)	N-m	(kgf-m)	(lbf-ft)
M6	10	5							3.3 to 4.2	(0.3 to 0.4)	(2.4 to 3.0)
M8	13	6	30	(3.0)	(21.5)	20	(2.0)	(14.5)	10	(1.0)	(7.2)
M10	17	8	65	(6.5)	(47)	50	(5.0)	(36)	20	(2.0)	(14.5)
M12	19	10	110	(11)	(80)	90	(9.0)	(65)	35	(3.5)	(25.5)
M14	22	12	180	(18)	(130)	140	(14)	(101)	55	(5.5)	(40)
M16	24	14	270	(27)	(195)	210	(21)	(152)	80	(8.0)	(58)
M18	27	14	400	(40)	(290)	300	(30)	(215)	120	(12)	(87)
M20	30	17	550	(55)	(400)	400	(40)	(290)	170	(17)	(123)
M22	32		750	(75)	(540)	550	(55)	(400)	220	(22)	(159)
M24	36		950	(95)	(690)	700	(70)	(510)	280	(28)	(205)
M27	41		1400	(140)	(1010)	1050	(105)	(760)	400	(40)	(290)
M30	46		1950	(195)	(1410)	1450	(145)	(1050)	550	(55)	(400)
M33	50		2600	(260)	(1880)	1950	(195)	(1410)	750	(75)	(540)
M36	55		3200	(320)	(2310)	2450	(245)	(1770)	950	(95)	(690)

GENERAL / Tightening

IMPORTANT: The following items are applied to both fine and coarse pitch threads.

1. Apply lubricant (i. e. white zinc B dissolved into Spindle oil) to nuts and bolts to reduce their friction coefficients.
The plated bolts require no lubricant.
2. Torque tolerance is $\pm 10\%$.
3. Be sure to use bolts of correct length. Bolts that are too long cannot be tightened, as the bolt tip comes into contact with the bottom of the bolt hole. Bolts that are too short cannot develop sufficient tightening force.
4. The torques given in the chart are for general use only. Do not use these torques if a different torque is given for a specific application.
5. Make sure that nut and bolt threads are clean before installing.
Remove dirt or corrosion, if any.

Bolt Tightening Order

When tightening two or more bolts, tighten them alternately, as shown, to ensure even tightening.

Equally tighten upper and lower alternately

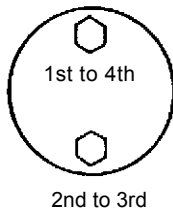

Tighten diagonally

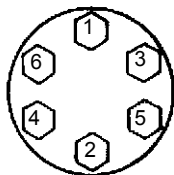

Tighten from center and diagonally

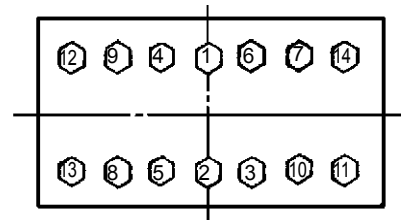

W105-01-01-003

GENERAL / Tightening

Service Recommendations for Split Flange

- IMPORTANT:**
1. Be sure to clean and inspect sealing surfaces. Scratches / roughness cause leaks and seal wear. Unevenness causes seal extrusion. If defects cannot be polished out, replace the component.
 2. Be sure to use only specified O-rings. Inspect O-rings for any damage. Take care not to file O-ring surfaces. When installing an O-ring into a groove, use grease to hold it in place.
 3. While lightly tightening split flange halves, check that split is centered and perpendicular to the port. Hand-tighten bolts to hold parts in place. Take care not to pinch the O-ring.
 4. Tighten bolts alternately and diagonally, as shown, to ensure even tightening.
 5. Do not use air wrenches. Using an air wrench often causes tightening of one bolt fully before tightening of the others, resulting in damage to O-rings or uneven tightening of bolts.

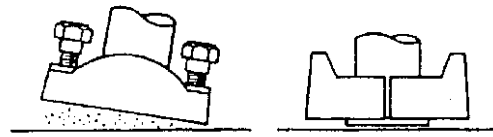

W105-01-01-015

Incorrect

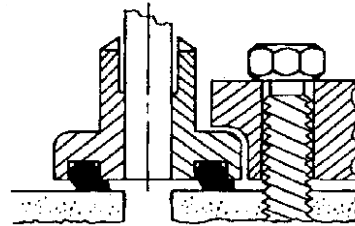

W105-01-01-016

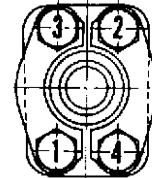

Correct

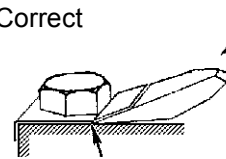

Bend along edge sharply

Incorrect

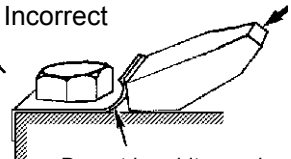

Do not bend it round

W105-01-01-008

Nut and Bolt Locking

- Lock Plate

IMPORTANT: Do not reuse lock plates. Do not try to bend the same point twice.

- Cotter Pin

IMPORTANT: Do not reuse cotter pins. Match the holes in the bolt and nut while tightening, not while loosening.

- Lock Wire

IMPORTANT: Apply wire to bolts in the bolt-tightening direction, not in the bolt-loosening direction.

Correct

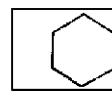

Correct

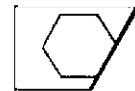

Incorrect

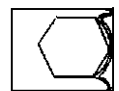

Bend along edge sharply



W105-01-01-009

Correct



Correct



Incorrect



Correct

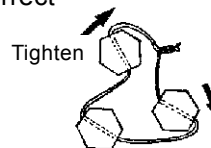

Tighten

Loosen

Incorrect



W105-01-01-010

GENERAL / Tightening

PIPING JOINT

IMPORTANT: The torques given in the chart are for general use only. Do not use these torques if a different torque is given for a specific application.

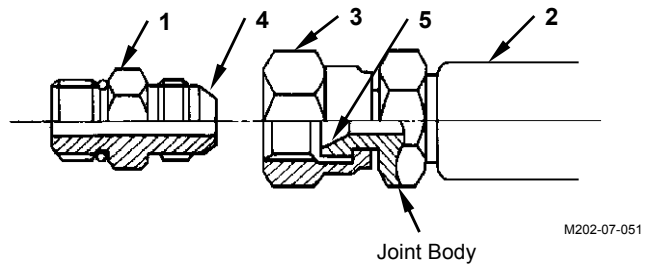

Union Joint

Metal sealing surfaces (4) and (5) of adapter (1) and hose (2) fit together to seal pressure oil. Union joints are used to join small-diameter lines.

- IMPORTANT:**
1. Do not over-tighten nut (3). Excessive force will be applied to metal sealing surfaces (4) and (5), possibly cracking adapter (1). Be sure to tighten nut (3) to specifications.
 2. Scratches or other damage to sealing surfaces (4) or (5) will cause oil leakage at the joint. Take care not to damage them when connecting/disconnecting.

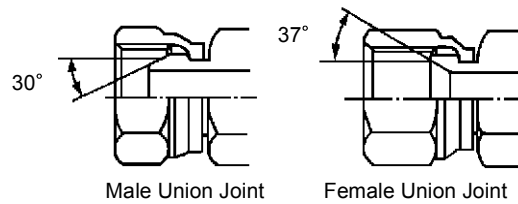

W105-01-01-017

Description	Wrench Size mm	Wrench Size mm	Tightening Torque
	Union Nut	Hose Fittings	N·m (kgf·m, lbf·ft)
30° male	17	17	24.5 (2.5,18)
	19	19	29.5 (3.0,21.5)
	22	22	39 (4.0,28.5)
	27	27	93 (9.5,69)
	32	32	137 (14,101)
	36	36	175 (18,129)
	41	41	205 (21,151)
37° female	17	14	24.5 (2.5,18)
	19	17	29.5 (3.0,21.5)
	22	19	39 (4.0,28.5)
	27	22	93 (9.5,69)
	32	27	137 (14,101)
	36	32	175 (18,129)
	41	36	205 (21,151)

NOTE: Tightening torque of 37° male coupling without union is similar to tightening torque of 37° female.

GENERAL / Tightening

O-ring Seal Joint

O-ring (6) seats against the end face of adapter (7) to seal pressure oil.

- IMPORTANT:**
1. Be sure to replace O-ring (6) with a new one when reconnecting.
 2. Before tightening nut (9), confirm that O-ring (6) is seated correctly in O-ring groove (e). Tightening nut (9) with O-ring (6) displaced will damage O-ring (6), resulting in oil leakage.
 3. Take care not to damage O-ring groove (e) or sealing surface (10).
Damage to O-ring (6) will cause oil leakage.
 4. If nut (9) is loose and oil is leaking, do not re-tighten nut (9). Replace O-ring (6) with a new one and check that O-ring (6) is correctly seated in place, tighten nut (9).

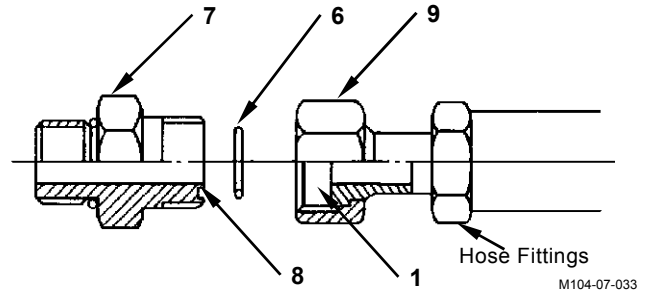

Wrench Size mm	Wrench Size mm	Tightening Torque
Union Nut	Hose Fittings	N·m (kgf·m, lbf·ft)
19	17	29.5 (3.0,21.5)
22	19	69 (7.0,51)
27	22	93 (9.5,69)
32	27	137 (14,101)
36	30,32	175 (18,129)
41	36	205 (21,151)
46	41	205 (21,151)

GENERAL / Tightening

Screw-In Connection

Depending on types of screw and sealing, different types of screw fittings are used.

IMPORTANT: Be sure to confirm that the thread pitch and thread type (tapered or straight) are the correct type before using any screw-in connection.

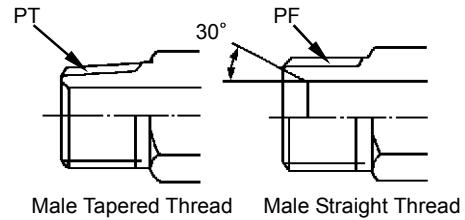

W105-01-01-018

Male Tapered Thread		
Wrench Size mm	Tightening Torque N·m (kgf·m, lbf·ft)	
Hose Fittings	FC material	SS material
19	14.5 (1.5,10.5)	34 (3.5,25)
22	29.5 (3.0,21.5)	49 (5.0,36)
27	49 (5.0,36)	93 (9.5,69)
36	69 (7.0,51)	157 (16,116)
41	108 (11,80)	205 (21,151)
50	157 (16,116)	320 (33,235)
60	195 (20,144)	

Seal Tape Application

Seal tape is used to seal clearances between male and female threads, so as to prevent any leaks between threads.

Be sure to apply just enough seal tape to fill up thread clearances. Do not overwrap.

- Application Procedure

Confirm that the thread surface is clean and, free of dirt or damage.

Apply seal tape around threads as shown. Wrap seal tape in the same direction as the threads.

Low-Pressure-Hose Clamp Tightening Torque

Low-pressure-hose clamp tightening torque differs depending on the type of clamp.

T-Bolt Type Band Clamp:

4.4 N·m (0.45 kgf·m, 3.25 lbf·ft)

Worm Gear Type Band Clamp:

5.9 to 6.9 N·m (0.6 to 0.7 kg·m, 4.3 to 5.1 lbf·ft)

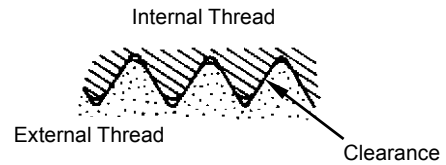

W105-01-01-019

Leave one to two pitch threads uncovered

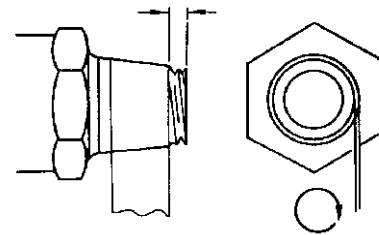

M114-07-041

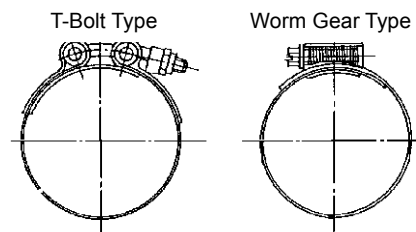

M114-07-043

M114-07-042

GENERAL / Tightening

Connecting Hose



CAUTION: When replacing hoses, be sure to use only genuine Hitachi service parts. Using hoses other than genuine Hitachi hoses may cause oil leaks, hose rupture or Separation of fitting, possibly resulting in a fire on the machine.

Do not install hoses kinked. Application of high oil pressure, vibration, or an impact to a kinked hose may result in oil leaks, hose rupture or separation of fitting. Utilize Print marks on hoses when installing to prevent hose from being kinked.

If hoses rub against each other, wear to the hoses will result, leading to hose rupture. Take necessary measures to protect hoses from rubbing against each other.

Take care so that hoses do not come into contact with moving parts or sharp objects.

Incorrect

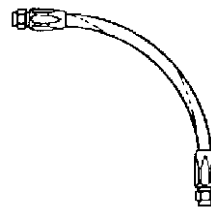

Correct

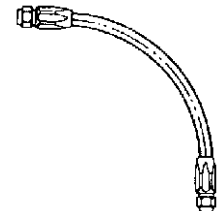

W105-01-01-011

Incorrect

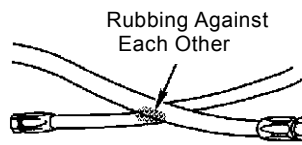

Correct

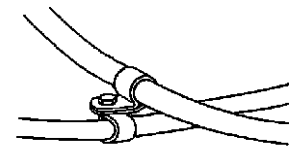

W105-01-01-012

Incorrect

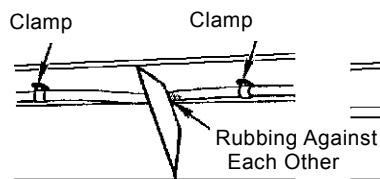

Correct

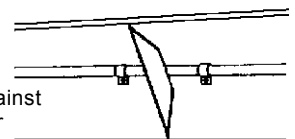

W105-01-01-013

Incorrect

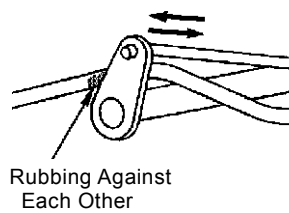

Correct

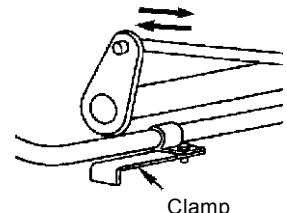

W105-01-01-014

GENERAL / Tightening

PERIODIC REPLACEMENT OF PARTS

To ensure safe operation, be sure to conduct periodic inspection of the machine. In addition, the parts listed below, if defective, may pose serious safety/fire hazards. It is very difficult to gauge the extent of deterioration, fatigue, or weakening of the parts listed below simply by visual inspection alone. For this reason, replace these parts at the intervals shown in the table below. However, if any of these parts are found to be defective, replace before starting operation, regardless of the interval.

Also, when replacing hoses, check the clamps for deformation, cracks, or other deterioration, and replace as necessary.

Be sure to perform periodic inspection of all hoses, as shown below, and replace or retighten any defective parts found, as necessary.

Consult your authorized dealer for correct replacement.

Periodic Replacement Parts		Replacement Intervals	
Engine	Fuel hose (Fuel tank to filter)	Every 2 years	
	Fuel hose (Fuel tank to injection pump)	Every 2 years	
	Heater hose (Heater to engine)	Every 2 years	
Hydraulic System	Base Machine	Pump suction hose	Every 2 years
		Pump delivery hose	Every 2 years
		Swing hose	Every 2 years
	Front Attachment	Boom cylinder line hose	Every 2 years
		Arm cylinder line hose	Every 2 years
		Bucket cylinder line hose	Every 2 years
		Pilot hose	Every 2 years

 **NOTE:** Be sure to replace seals, such as O-rings and gaskets, when replacing hoses.

SECTION 2 UPPERSTRUCTURE



—CONTENTS—

Group 1 Cab

Dimensions of the Cab Glass..... W2-1-1

Group 2 Counterweight

Removal and Installation of
Counterweight..... W2-2-1

Group 3 Pump Device

Removal and Installation of
Pump Device..... W2-3-1
Removal of Pump Device..... W2-3-2
Installation of Pump Device..... W2-3-12
Adding oil to Pump Transmission..... W2-3-22
Bleeding Air from Pump..... W2-3-24
Disassembly of Pump Transmission..... W2-3-26
Assembly of Pump Transmission..... W2-3-30
Disassembly of Main Pump..... W2-3-34
Assembly of Main Pump..... W2-3-42
Maintenance Standard..... W2-3-50
Disassembly of Regulator for
Main Pump..... W2-3-52
Assembly of Regulator for Main Pump.... W2-3-58
Disassembly of Fan Motor Drive Pump... W2-3-64
Assembly of Fan Motor Drive Pump..... W2-3-70
Maintenance Standard..... W2-3-74
Disassembly of Regulator for Fan
Motor Drive Pump..... W2-3-76
Assembly of Regulator for Fan
Motor Drive Pump..... W2-3-82
Structure of Pilot Pump..... W2-3-88
Structure of Pump Transmission Oil
Circulation Pump and Air Conditioner
Compressor Drive Pump..... W2-3-90

Group 4 Control Valve

Removal and Installation of
Control Valve..... W2-4-1
Disassembly of Control Valve..... W2-4-7
Assembly of Control Valve..... W2-4-16
Disassembly and Assembly of
Main Relief Valve and Overload
Relief Valve..... W2-4-20
Structure of Make-Up Valve..... W2-4-22
Identification of Plunger..... W2-4-23

Group 5 Swing Device

Removal and Installation of
Swing Device..... W2-5-1
Disassembly of Swing Device..... W2-5-4
Assembly of Swing Device..... W2-5-12
Disassembly of Swing Motor..... W2-5-20
Assembly of Swing Motor..... W2-5-24
Maintenance Standard..... W2-5-28
Disassembly and Assembly
Valve Unit..... W2-5-30

Group 6 DQR Valve

Removal and Installation of DQR Valve..... W2-6-1
Structure of DQR Valve..... W2-6-4

Group 7 Fan Drive Motor

Removal and Installation of
Fan Drive Motor..... W2-7-1
Disassembly of Oil Cooler Fan Motor..... W2-7-20
Assembly of Oil Cooler Fan Motor..... W2-7-22
Maintenance Standard..... W2-7-24
Structure of Radiator Fan Motor
and Engine Room Fan Motor..... W2-7-26

Group 8 Solenoid Valve

Removal and Installation of Solenoid Valve Unit	W2-8-1
Structure of Proportional Solenoid Valve	W2-8-5
Disassembly and Assembly of Proportional Solenoid Valve	W2-8-6
Structure of Solenoid.....	W2-8-8

Group 9 Shuttle Valve

Removal and Installation of Shuttle Valve	W2-9-1
Structure of Shuttle Valve.....	W2-9-3

Group 10 Block Valve with Folding Stairway

Removal and Installation of Block Valve with Folding Stairway	W2-10-1
Disassembly of Block Valve	W2-10-4
Assembly of Block Valve	W2-10-6
Structure of Solenoid Valve (10).....	W2-10-8
Structure of Solenoid Valve (13).....	W2-10-9
Structure of Relief Valve (16)	W2-10-10
Structure of Slow Return Valve.....	W2-10-11

Group 11 Compressor Drive Motor

Removal and Installation of Compressor Drive Motor	W2-11-1
Disassembly of Compressor Drive Motor	W2-11-4
Assembly of Compressor Drive Motor	W2-11-6

Group 12 Air Conditioner

Work After Replacing Component	W2-12-1
Add Compressor Oil.....	W2-12-1
Charge Air Conditioner With Refrigerant	W2-12-2

Group 13 Lift Cylinder

Removal and Installation of Lift Cylinder	W2-13-1
Disassembly of Lift Cylinder	W2-13-4
Assembly of Lift Cylinder.....	W2-13-6

Group 14 Arm Extend Priority Valve

Removal and Installation of Pump Device	W2-14-1
Structure of Arm Extend Priority Valve	W2-14-4

UPPERSTRUCTURE / Cab

DIMENSIONS OF THE CAB GLASS

 NOTE: Material: JISR3211 or equivalent
1 mm=0.03927 in

Unit: mm

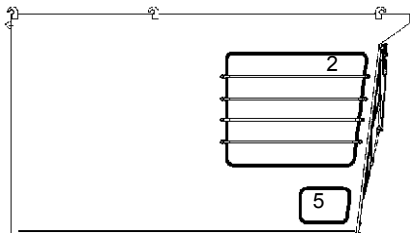

W18G-02-01-003

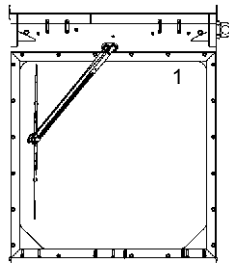

W18G-02-01-001

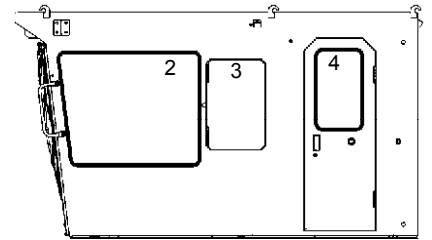

W18G-02-01-002

Chamfer corner (4 places)

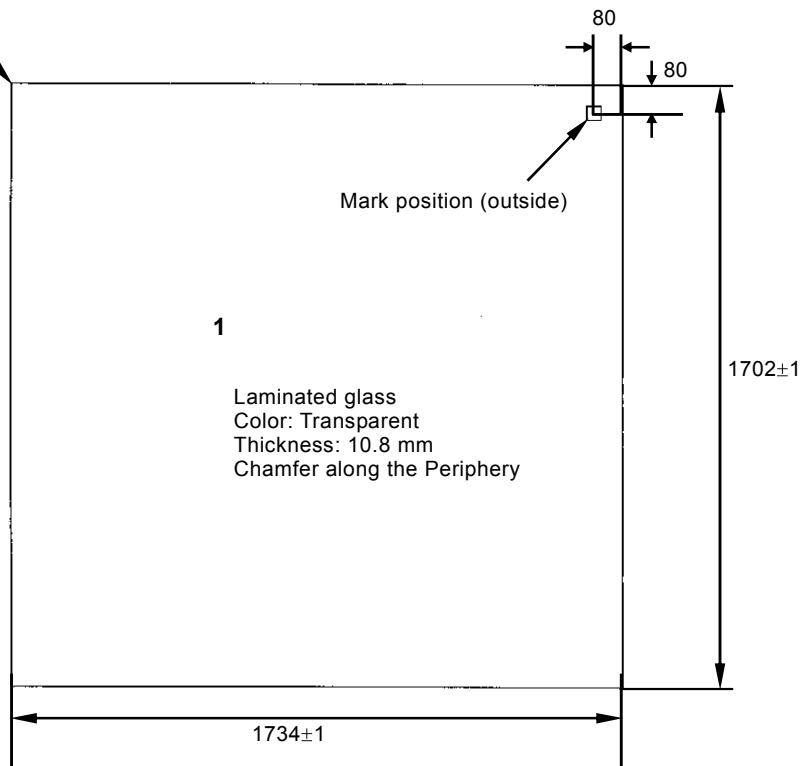

W18G-02-01-004

UPPERSTRUCTURE / Cab

Unit: mm

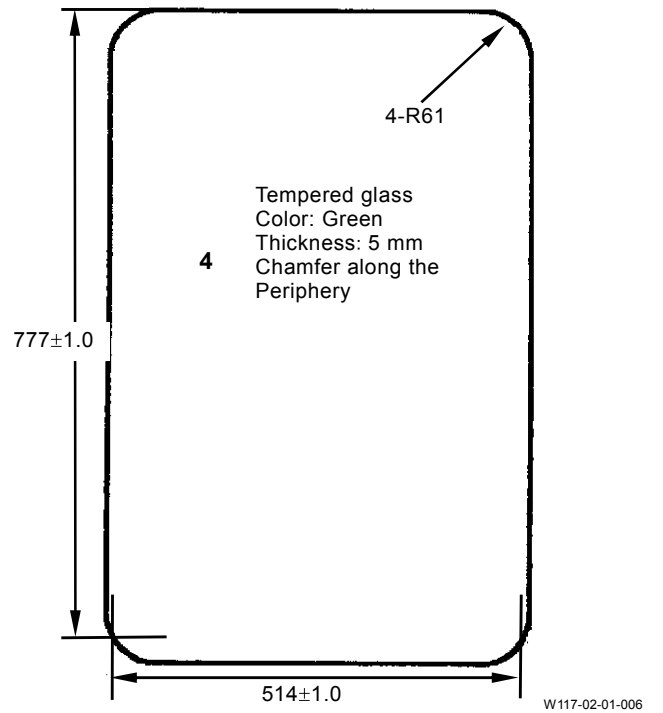
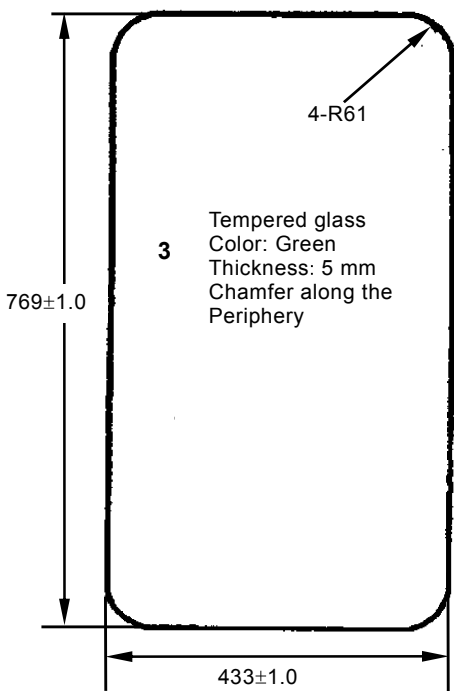
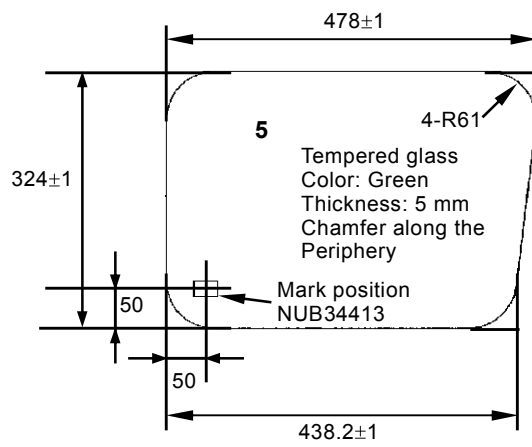
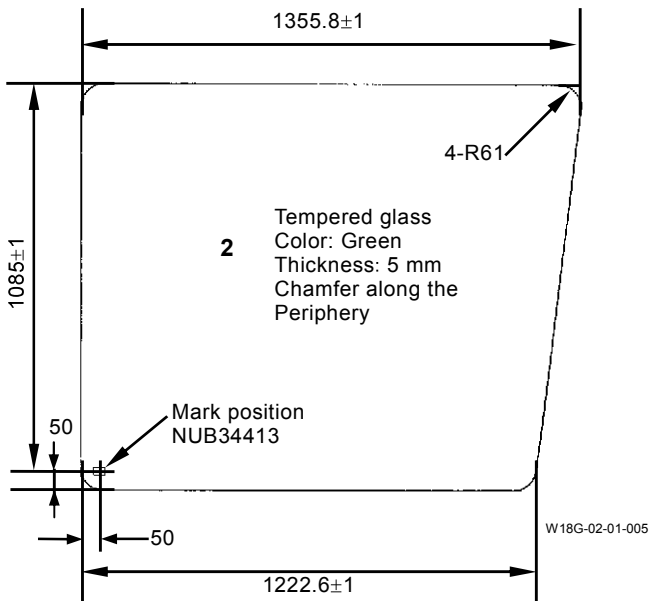

UPPERSTRUCTURE / Counterweight

REMOVAL AND INSTALLATION OF COUNTERWEIGHT



CAUTION: Park the machine on a solid and level surface. Lower the bucket to the ground steady before doing any work.

Do not operate the machine or the front attachment without the counterweight. Otherwise the machine may tip over.

Removal

1. Remove nuts (7) (3 used), washers (6) (6 used), and bolts (5) (3 used) from right handrails (2, 3).

 : 19 mm



CAUTION: Right handrail (2) weight: 20 kg (44 lb)

Right handrail (3) weight: 28 kg (62 lb)

2. Remove bolts (4) (14 used) from right handrails (2, 3). Remove right handrails (2, 3) from right counterweight (1).

 : 19 mm

3. Remove the left handrail in the same way as steps 1 to 2.

4. Remove bolts (9, 12) (8 used for each) from covers (8, 11) (2 used for each). Remove covers (8, 11) (2 used for each) from right sub weight (10).

 : 19 mm

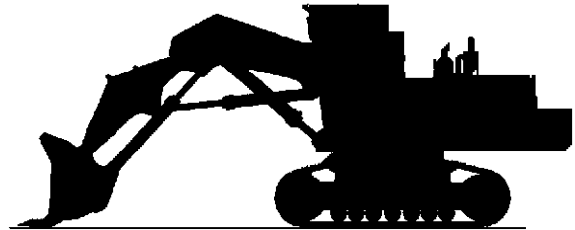

W18G-03-02-013

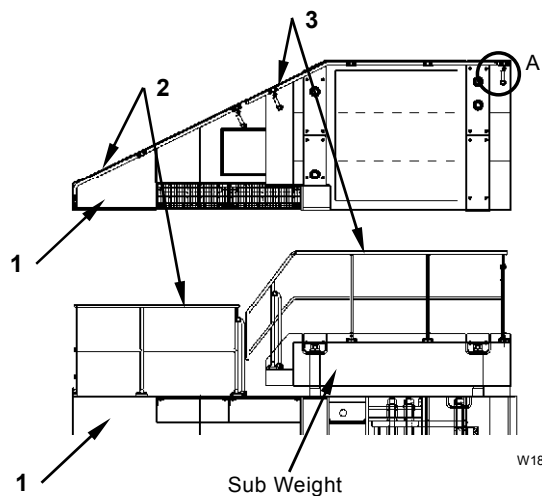

W18G-02-02-001

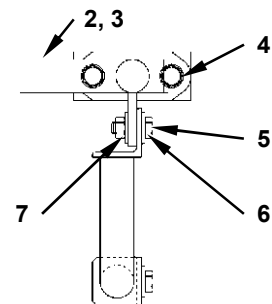

Detail A

W18G-02-02-002

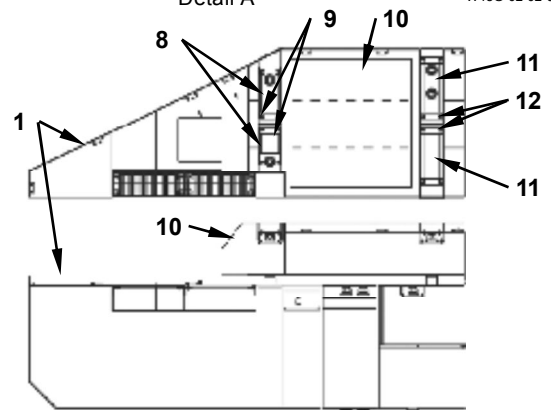

W18G-02-02-003

BUY NOW

**Then Instant Download
the Complete Manual
Thank you very much!**