

# Workshop Manual

**ZAXIS**

**330/330LC**

**350H/350LCH**

**370MTH**

Vol No.: W1HHE-00

---

---

# SECTION 1 GENERAL INFORMATION



## — CONTENTS —

### **Group 1 Precautions for Disassembling and Assembling**

Precautions for Disassembling and Assembling.....	W1-1-1
Maintenance Standard Terminology.....	W1-1-7

### **Group 2 Tightening Torque**

Tightening Torque Specification.....	W1-2-1
Torque Chart .....	W1-2-3
Piping Joint .....	W1-2-6
Periodic Replacement of Parts .....	W1-2-10

### **Group 3 Painting**

Painting.....	W1-3-1
---------------	--------

---

---

(Blank)

## GENERAL / Precautions for Disassembling and Assembling

---

### PRECAUTIONS FOR DISASSEMBLING AND ASSEMBLING

#### Precautions for Disassembling and Assembling

- Clean the Machine

Thoroughly wash the machine before bringing it into the shop. Bringing a dirty machine into the shop may cause machine components to be contaminated during disassembling/assembling, resulting in damage to machine components, as well as decreased efficiency in service work.

- Inspect the Machine

Be sure to thoroughly understand all disassembling/assembling procedures beforehand, to help avoid incorrect disassembling of components as well as personal injury.

Check and record the items listed below to prevent problems from occurring in the future.

- The machine model, machine serial number, and hour meter reading.
- Reason for disassembly (symptoms, failed parts, and causes).
- Clogging of filters and oil, water or air leaks, if any.
- Capacities and condition of lubricants.
- Loose or damaged parts.

- Prepare and Clean Tools and Disassembly Area

Prepare the necessary tools to be used and the area for disassembling work.

- Precautions for Disassembling

- To prevent dirt from entering, cap or plug the removed pipes.
- Before disassembling, clean the exterior of the components and place on a work bench.
- Before disassembling, drain gear oil from the reduction gear.
- Be sure to provide appropriate containers for draining fluids.
- Use matching marks for easier reassembling.
- Be sure to use the specified special tools, when instructed.
- If a part or component cannot be removed after removing its securing nuts and bolts, do not attempt to remove it forcibly. Find the cause(s), then take the appropriate measures to remove it.
- Orderly arrange disassembled parts. Mark and tag them as necessary.
- Store common parts, such as bolts and nuts with reference to where they are to be used and in a manner that will prevent loss.
- Inspect the contact or sliding surfaces of disassembled parts for abnormal wear, sticking, or other damage.
- Measure and record the degree of wear and clearances.

---

## GENERAL / Precautions for Disassembling and Assembling

---

- Precautions for Assembling

- Be sure to clean all parts and inspect them for any damage. If any damage is found, repair or replace part.
- Dirt or debris on the contact or sliding surfaces may shorten the service life of the machine. Take care not to contaminate any contact or sliding surfaces.
- Be sure to replace O-rings, backup rings, and oil seals with new ones once they are disassembled. Apply a film of grease before installing.
- Be sure that liquid-gasket-applied surfaces are clean and dry.
- If an anti-corrosive agent has been used on a new part, be sure to thoroughly clean the part to remove the agent.
- Utilize matching marks when assembling.
- Be sure to use the designated tools to assemble bearings, bushings and oil seals.
- Keep a record of the number of tools used for disassembly/assembly. After assembling is complete, count the number of tools, so as to make sure that no forgotten tools remain in the assembled machine.

### Bleeding Air from Hydraulic System

When hydraulic oil is drained, the suction filter or the suction lines are replaced, or the removal and installation of the pump, swing motor, travel motor or cylinder is done, bleed air from the hydraulic system in the following procedures:

**IMPORTANT: If the engine is started with air trapped in the hydraulic pump housing, damage to the pump may result. If the hydraulic motor is operated with air trapped in the hydraulic motor housing, damage to the motor may result. If the cylinder is operated with air trapped in the cylinder tube, damage to the cylinder may result. Be sure to bleed air before starting the engine.**

- Bleeding Air from Hydraulic Pump

- Remove the air bleeding plug from the top of the pump and fill the pump housing with hydraulic oil.
- After the pump housing is filled with hydraulic oil, temporarily tighten the plug. Then, start the engine and run at slow idle speed.
- Slightly loosen the plug to bleed air from the pump housing until hydraulic oil oozes out.
- After bleeding all the air, securely tighten the plug.

- Bleeding Air from Travel Motor / Swing Motor

- With the drain plug / hose on travel motor / swing motor removed, fill the motor case with hydraulic oil.

## GENERAL / Precautions for Disassembling and Assembling

---

- Bleeding Air from Hydraulic Circuit

- After refilling hydraulic oil, start the engine. While operating each cylinder, swing motor and travel motor evenly, operate the machine under light loads for 10 to 15 minutes. Slowly start each operation (never fully stroke the cylinders during initial operation stage). As the pilot oil circuit has an air bleed device, air trapped in the pilot oil circuit will be bled while performing the above operation for approx. 5 minutes.
- Reposition the front attachment to check hydraulic oil level.
- Stop the engine. Recheck hydraulic oil level. Replenish oil as necessary.

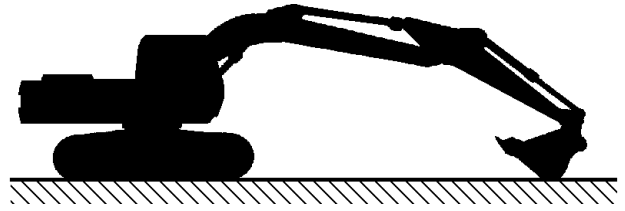

M104-07-021

# GENERAL / Precautions for Disassembling and Assembling

## Floating Seal Precautions

1. In general, replace the floating seal with a new one after disassembling. If the floating seal is to be reused, follow these procedures:

- (1) Keep seal rings together as a matched set with seal ring faces together. Insert a piece of cardboard to protect surfaces. Apply oil to the sliding surface (C) on seal ring (A).
- (2) Check the slide surface (C) on seal ring (A) for scuffing, scoring, corrosion, deformation or uneven wear.
- (3) Check O-ring (B) for tears, breaks, deformation or hardening.

2. If incorrectly assembled, oil leakage or damage will occur. Be sure to do the following, to prevent trouble.

- (1) Clean the floating seal and seal mounting bores with cleaning solvent. Use a wire brush to remove mud, rust or dirt. After cleaning, thoroughly dry parts with compressed air.
- (2) Clean the floating seal and seal mounting bores. Check the bore surface for scuffing or scoring by touching the surface.
- (3) Check that the O-ring is not twisted, and that it is installed correctly on the seal ring.
- (4) After installing the floating seal, check that seal ring surface (C) is parallel with seal mating face (D) by measuring the distances (C) and (D) at point (a) and (b), as illustrated. If these distances differ, correct the O-ring seating.

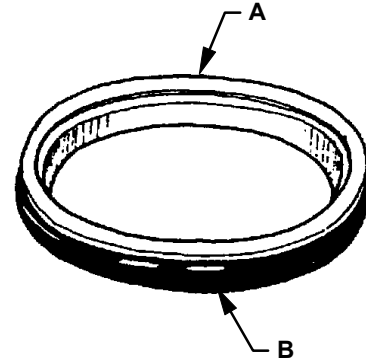

W105-03-05-019

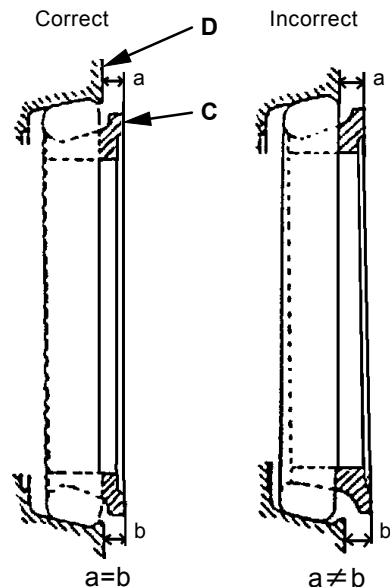
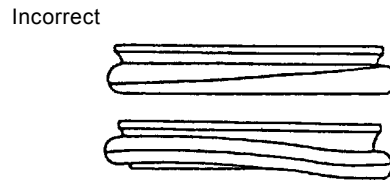
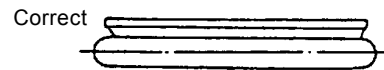
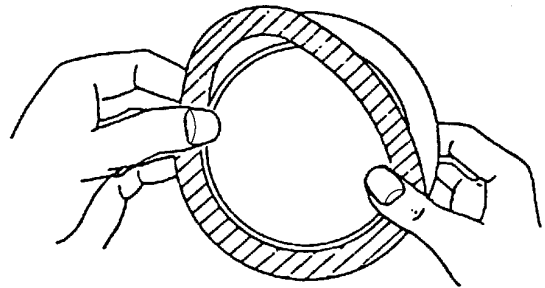

W110-03-05-020

W110-03-05-004

## GENERAL / Precautions for Disassembling and Assembling

### Precautions for Using Nylon Sling

1. Follow the precautions below to use nylon slings safely.
  - Attach protectors (soft material) on the corners of the load so that the nylon sling does not directly contact the corners. This will prevent the nylon sling from being damaged and the lifted load from slipping.
  - Lower the temperature of the lifted load to lower than 100 °C (212 °F). If unavoidably lifting a load with a temperature of 100 °C (212 °F) or more, reduce the load weight.
  - Do not lift acid or alkali chemicals.
  - Take care not to allow the sling to become wet. The load may slip.
  - When required to use more than one sling, use slings with the same width and length to keep the lifted load balanced.
  - When lifting a load using an eyehole, be sure to eliminate any gaps between the sling and load. (Refer to the right illustration.) Reduce the load weight so that it is less than 80 % of the sling breaking force.
  - Avoid using twisted, bound, connected, or hitched slings.
  - Do not place any object on twisted or bent slings. (Refer to the right illustration.)
  - When removing the slings from under the load, take care not to damage the nylon slings. Avoid contact with protrusions.
  - Avoid dragging slings on the ground, throwing slings or pushing slings with a metal object.
  - When using with other types of slings (wire rope) or accessories (shackle), protect the joint so that the nylon sling is not damaged.
  - Store the nylon slings indoors so they won't deteriorate with heat, sun light, or chemicals.

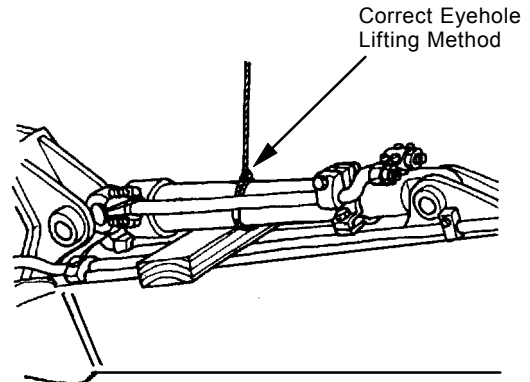

W102-04-02-016

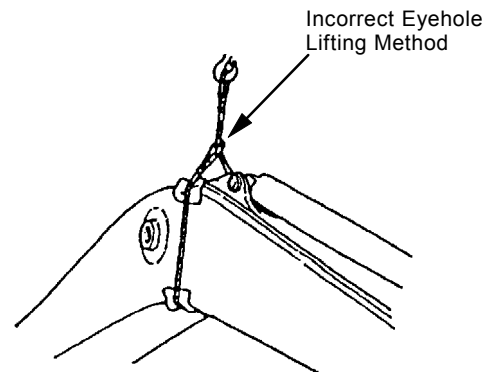

W105-04-01-008

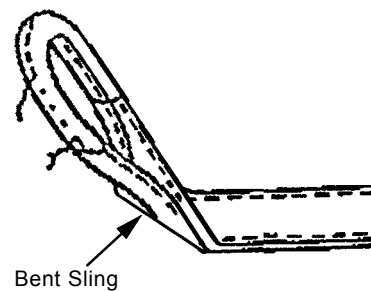

W162-01-01-009



## GENERAL / Precautions for Disassembling and Assembling



**CAUTION:** If a load is lifted with a damaged nylon sling, serious personal injury may result. Be sure to visually check the nylon sling for any damage before using.

2. Before using a nylon sling, visually check the nylon sling for any damage corresponding to examples shown to the right. If any damage is found, cut and discard the sling. Even if no damage is found, do not use slings older than 7-years.

Damaged Appearance Broken Sewing Thread

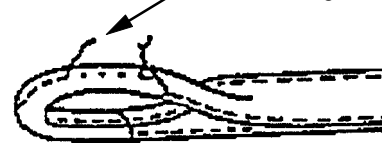

W162-01-01-002

Scuffing



W162-01-01-003

Fuzz

Broken Sewing Thread



W162-01-01-004

Broken Sewing Thread



W162-01-01-005

Broken Sewing Thread



W162-01-01-006

Scoring

Separation of Belt



W162-01-01-007

Fuzz

Scuffing

Broken Warp



W162-01-01-008

## **GENERAL / Precautions for Disassembling and Assembling**

---

### **MAINTENANCE STANDARD TERMINOLOGY**

#### **“Standard”**

1. Dimension for parts on a new machine.
2. Dimension of new components or assemblies adjusted to specification.

#### **“Allowable Limit”**

1. Normal machine performance cannot be accomplished after exceeding this limit.
2. Repair or adjustment is impossible after exceeding this limit.
3. Therefore, in consideration of operation efficiency and maintenance expense, proper maintenance shall be carried out before reaching the “Allowable Limit”.

## **GENERAL / Precautions for Disassembling and Assembling**

---

(Blank)

## GENERAL / Tightening Torque

### TIGHTENING TORQUE SPECIFICATION

No.	Descriptions		Bolt Dia	Q'ty	Wrench Size (mm)	Torque		
			mm			N·m	(kgf·m)	(lbf·ft)
1	Engine cushion rubber mounting bolt		18	4	27	400	(41)	(300)
2	Engine bracket mounting bolt	(Fan Side)	10	10	17	60	(6)	(43)
		(Pump Side)	12	8	19	90	(9)	(65)
3	Engine oil filter mounting bolt		10	4	17	50	(5.1)	(37)
4	Radiator mounting bolt		16	4	24	210	(21)	(151)
5	Hydraulic oil tank mounting bolt		18	4	27	300	(30.5)	(220)
6	Fuel tank mounting bolt		16	6	24	210	(21)	(151)
7	ORS fittings for hydraulic hoses and piping		1 - $\frac{3}{16}$ -12UNF		36	175	(18)	(130)
			1 - $\frac{7}{16}$ -12UNF		41	210	(21.5)	(155)
			1 - $\frac{11}{16}$ -12UNF		50	255	(26)	(188)
8	Pump mounting bolt		10	8	17	50	(5.1)	(37)
9	Control valve mounting bolt		16	4	24	210	(21.5)	(155)
10	Control valve bracket mounting bolt		16	4	24	210	(21.5)	(155)
11	Swing device mounting bolt		22	12	32	640	(65)	(470)
12	Swing motor mounting bolt		12	12	10	90	(9.2)	(66)
13	Battery mounting nut		10	2	17	50	(5.1)	(37)
14	Cab mounting nut		16	4	24	210	(21.5)	(155)
15	Swing bearing mounting bolt to upperstructure		27	36	36	1226	(125)	(905)
	Swing bearing mounting bolt to undercarriage		27	36	36	1226	(125)	(905)
16	Travel device mounting bolt	ZAXIS330, 330LC, 350H, 350LCH	20	40	30	620	(63)	(460)
		ZAXIS370MTH	22	40	32	740	75	(540)
17	Sprocket mounting bolt	ZAXIS330, 330LC, 350H, 350LCH	20	32	30	490	(50)	(360)
		ZAXIS370MTH	22	48	32	740	75	(540)
18	Upper roller mounting bolt	ZAXIS330, 330LC, 350H, 350LCH	16	16	24	270	(27.5)	(200)
		ZAXIS370MTH	18	16	27	390	40	(290)
19	Lower roller mounting bolt	ZAXIS330, 330LC	20	64	30	670	(68)	(490)
		ZAXIS350H, 350LCH	20	72	30	670	(68)	(490)
		ZAXIS370MTH	22	64	32	740	75	(540)
20	Track shoe bolt	ZAXIS330, 330LC	22	360	30	1130	(115)	(830)
		ZAXIS350H, 350LCH	22	384	30	1130	(115)	(830)
		ZAXIS370MTH	24	392	32	1370	(140)	(1010)
21	Track guard mounting bolt	ZAXIS330, 330LC	20	8	30	620	(63)	(460)
		ZAXIS350H, 350LCH	20	24	30	620	(63)	(460)
		ZAXIS370MTH	22	28	32	740	(75)	(540)
22	Coupling, Jubilee and T-bolt clamp of low pressure piping		8	—	13	10.3 to 12.4	(1.05 to 1.26)	(7.59 to 9.11)
			6	—	11	5.9	(0.6)	(4.3)
23	Front pin-retaining bolt and nut		18	—	27	400	(41)	(300)
			20	—	30	550	(56)	(405)
			22	—	32	750	(76.5)	(550)
24	Counterweight mounting bolt	ZAXIS330, 330LC	32	4	50	2260	230	(1665)
		ZAXIS350H, 350LCH, 370MTH	36	4	55	2840	290	(2100)

## GENERAL / Tightening Torque

---

-  NOTE 1. Apply lubricant (e.g. white zinc B dissolved into spindle oil) to bolts and nuts to reduce friction coefficient of them.
2. Make sure bolt and nut threads are clean before installing.
3. Apply LOCTITE to threads before installing and tightening swing bearing mounting bolts and lower roller mounting bolts.

# GENERAL / Tightening Torque

## TORQUE CHART

**⚠ CAUTION:** Use tools appropriate for the work to be done. Makeshift tools and procedures can create safety hazards. For loosening and tightening nuts and bolts, use correct size tools. Otherwise, tightening tools may slip, potentially causing personal injury.



SA-040

### Bolt Types

Tighten nuts or bolts correctly to torque specifications. Four different types and grades of bolt are employed. Make sure to employ correct bolts and tighten them correctly when assembling the machine or components.

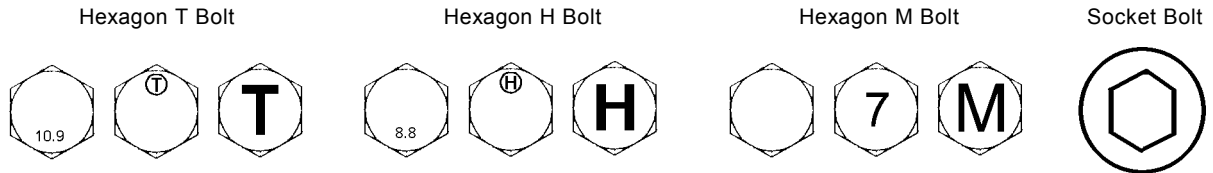

W162-01-01-001

### Specified Tightening Torque Chart

Bolt Dia.	Wrench Size	Hexagon Wrench Size	T Bolt			H Bolt, Socket bolt			M Bolt		
			N·m	(kgf·m)	(lbf·ft)	N·m	(kgf·m)	(lbf·ft)	N·m	(kgf·m)	(lbf·ft)
M 8	13	6	29.5	(3)	(22)	19.5	(2)	(14.5)	9.8	(1)	(7.2)
M 10	17	8	64	(6.5)	(47)	49	(5)	(36)	19.5	(2)	(14.5)
M 12	19	10	108	(11)	(80)	88	(9)	(65)	34	(3.5)	(25.5)
M 14	22	12	175	(18)	(130)	137	(14)	(101)	54	(5.5)	(40)
M 16	24	14	265	(27)	(195)	205	(21)	(152)	78	(8)	(58)
M 18	27	14	390	(40)	(290)	295	(30)	(220)	118	(12)	(87)
M 20	30	17	540	(55)	(400)	390	(40)	(290)	167	(17)	(123)
M 22	32	17	740	(75)	(540)	540	(55)	(400)	215	(22)	(159)
M 24	36	19	930	(95)	(690)	690	(70)	(505)	275	(28)	(205)
M 27	41	19	1370	(140)	(1010)	1030	(105)	(760)	390	(40)	(290)
M 30	46	22	1910	(195)	(1410)	1420	(145)	(1050)	540	(55)	(400)
M 33	50	24	2550	(260)	(1880)	1910	(195)	(1410)	740	(75)	(540)
M 36	55	27	3140	(320)	(2310)	2400	(245)	(1770)	930	(95)	(690)

## GENERAL / Tightening Torque

**IMPORTANT:** The following items are applied to both fine and coarse pitch threads.

1. Apply lubricant (i. e. white zinc B dissolved into Spindle oil) to nuts and bolts to reduce their friction coefficients.  
The plated bolts require no lubricant.
2. Torque tolerance is  $\pm 10\%$ .
3. Be sure to use bolts of correct length. Bolts that are too long cannot be tightened, as the bolt tip comes into contact with the bottom of the bolt hole. Bolts that are too short cannot develop sufficient tightening force.
4. The torques given in the chart are for general use only. Do not use these torques if a different torque is given for a specific application.
5. Make sure that nut and bolt threads are clean before installing.  
Remove dirt or corrosion, if any.

### Bolt Tightening Order

When tightening two or more bolts, tighten them alternately, as shown, to ensure even tightening.

Equally tighten upper and lower alter-

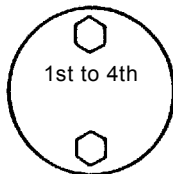

Tighten diagonally

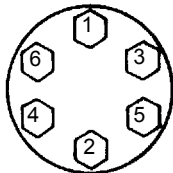

Tighten from center and diago-

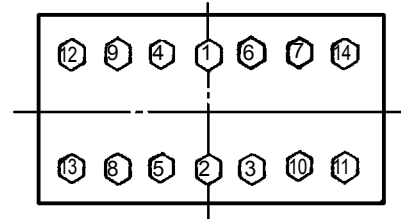

W105-01-01-003

# GENERAL / Tightening Torque

## Service Recommendations for Split Flange

- IMPORTANT:**
1. Be sure to clean and inspect sealing surfaces. Scratches / roughness cause leaks and seal wear. Unevenness causes seal extrusion. If defects cannot be polished out, replace the component.
  2. Be sure to use only specified O-rings. Inspect O-rings for any damage. Take care not to file O-ring surfaces. When installing an O-ring into a groove, use grease to hold it in place.
  3. While lightly tightening split flange halves, check that split is centered and perpendicular to the port. Hand-tighten bolts to hold parts in place. Take care not to pinch the O-ring.
  4. Tighten bolts alternately and diagonally, as shown, to ensure even tightening.
  5. Do not use air wrenches. Using an air wrench often causes tightening of one bolt fully before tightening of the others, resulting in damage to O-rings or uneven tightening of bolts.

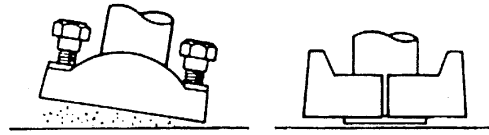

W105-01-01-015

**WRONG**

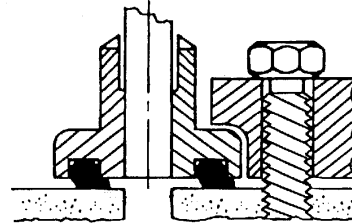

W105-01-01-016

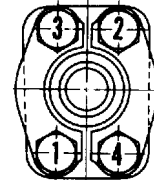

W105-01-01-008

**RIGHT**

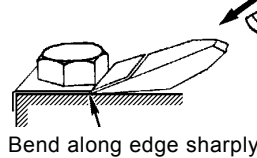

**WRONG**

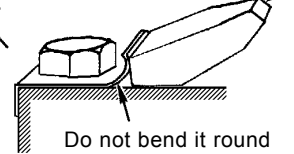

## Nut and Bolt Locking

- Lock Plate

**IMPORTANT:** Do not reuse lock plates. Do not try to bend the same point twice.

- Cotter Pin

**IMPORTANT:** Do not reuse cotter pins. Match the holes in the bolt and nut while tightening, not while loosening.

- Lock Wire

**IMPORTANT:** Apply wire to bolts in the bolt-tightening direction, not in the bolt-loosening direction.

**RIGHT**

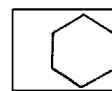

**RIGHT**

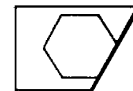

**WRONG**

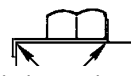
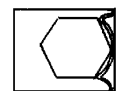

Bend along edge sharply



W105-01-01-009

**RIGHT**

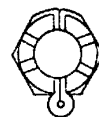

**RIGHT**



**WRONG**

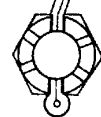

**RIGHT**

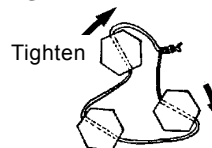

Loosen

**WRONG**

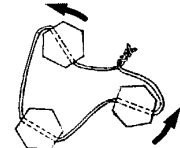

W105-01-01-010



## GENERAL / Tightening Torque

### PIPING JOINT

**IMPORTANT:** The torques given in the chart are for general use only. Do not use these torques if a different torque is given for a specific application.

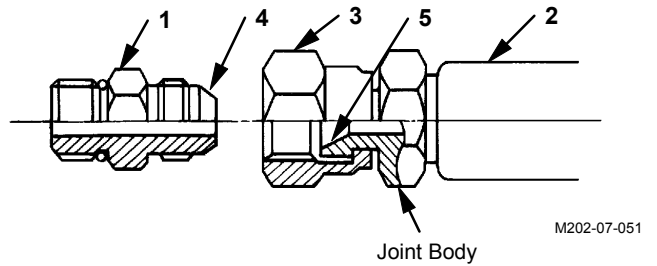

#### Union Joint

Metal sealing surfaces (4) and (5) of adapter (1) and hose (2) fit together to seal pressure oil. Union joints are used to join small-diameter lines.

- IMPORTANT:**
1. Do not over-tighten nut (3). Excessive force will be applied to metal sealing surfaces (4) and (5), possibly cracking adapter (1). Be sure to tighten nut (3) to specifications.
  2. Scratches or other damage to sealing surfaces (4) or (5) will cause oil leakage at the joint. Take care not to damage them when connecting/disconnecting.

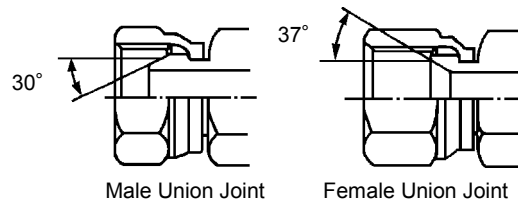

W105-01-01-017

Description	Wrench Size mm	Wrench Size mm	Tightening Torque
	Union Nut	Hose Fittings	N·m (kgf·m, lbf·ft)
30° male	17	17	24.5 (2.5,18)
	19	19	29.5 (3.0,21.5)
	22	22	39 (4.0,28.5)
	27	27	93 (9.5,69)
	32	32	137 (14.0,101)
	36	36	175 (18.0,129)
	41	41	205 (21.0,151)
37° female	17	14	24.5 (2.5,18)
	19	17	29.5 (3.0,21.5)
	22	19	39 (4.0,28.5)
	27	22	93 (9.5,69)
	32	27	137 (14.0,101)
	36	32	175 (18.0,129)
	41	36	205 (21.0,151)

**NOTE:** Tightening torque of 37° male coupling without union is similar to tightening torque of 37° female.

## GENERAL / Tightening Torque

### O-ring Seal Joint

O-ring (6) seats against the end face of adapter (7) to seal pressure oil.

- IMPORTANT:**
1. Be sure to replace O-ring (6) with a new one when reconnecting.
  2. Before tightening nut (9), confirm that O-ring (6) is seated correctly in O-ring groove (e). Tightening nut (9) with O-ring (6) displaced will damage O-ring (6), resulting in oil leakage.
  3. Take care not to damage O-ring groove (e) or sealing surface (10). Damage to O-ring (6) will cause oil leakage.
  4. If nut (9) is loose and oil is leaking, do not re-tighten nut (9). Replace O-ring (6) with a new one and check that O-ring (6) is correctly seated in place, tighten nut (9).

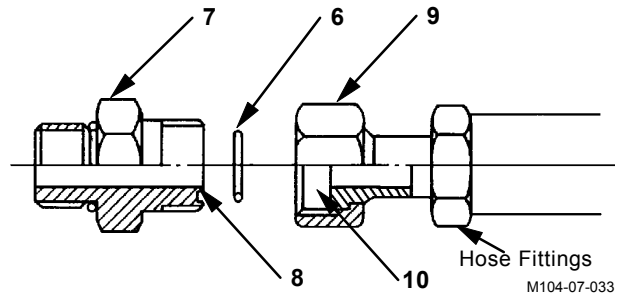

Wrench Size mm	Wrench Size mm	Tightening Torque
Union Nut	Hose Fittings	N-m (kgf-m, lbf-ft)
19	17	29.5 (3.0,21.5)
22	19	69 (7.0,51)
27	22	93 (9.5,69)
32	27	137 (14.0,101)
36	30,32	175 (18.0,129)
41	36	205 (21.0,151)
46	41	205 (21.0,151)

## GENERAL / Tightening Torque

### Screw-In Connection

Depending on types of screw and sealing, different types of screw fittings are used.

**IMPORTANT:** Be sure to confirm that the thread pitch and thread type (tapered or straight) are the correct type before using any screw-in connection.

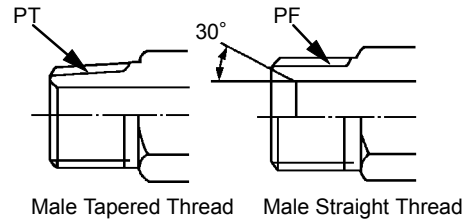

W105-01-01-018

Male Tapered Thread		
Wrench Size mm	Tightening Torque N·m (kgf·m, lbf·ft)	
	FC material	SS material
Hose Fittings		
19	14.5 (1.5,10.5)	34 (3.5,25)
22	29.5 (3.0,21.5)	49 (5.0,36)
27	49 (5.0,36)	93 (9.5,69)
36	69 (7.0,51)	157 (16,116)
41	108 (11,80)	205 (21,151)
50	157 (16,116)	320 (33,235)
60	195 (20,144)	

### Seal Tape Application

Seal tape is used to seal clearances between male and female threads, so as to prevent any leaks between threads.

Be sure to apply just enough seal tape to fill up thread clearances. Do not overwrap.

- Application Procedure

Confirm that the thread surface is clean and, free of dirt or damage.

Apply seal tape around threads as shown. Wrap seal tape in the same direction as the threads.

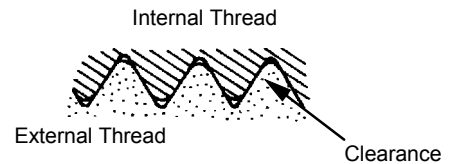

W105-01-01-019

### Low-Pressure-Hose Clamp Tightening Torque

Low-pressure-hose clamp tightening torque differs depending on the type of clamp.

T-Bolt Type Band Clamp:

4.4 N·m ( 0.45 kgf·m, 3.25 lbf·ft )

Worm Gear Type Band Clamp:

5.9 to 6.9 N·m (0.6 to 0.7 kg·m, 4.3 to 5.1 lbf·ft)

Leave one to two pitch threads uncovered

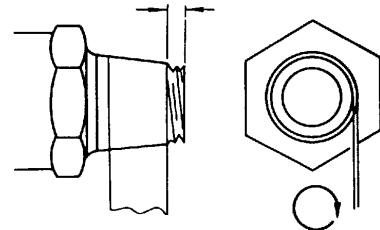

M114-07-041

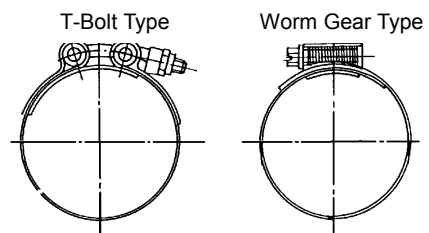

M114-07-043

M114-07-042

## GENERAL / Tightening Torque

### Connecting Hose



**CAUTION:** When replacing hoses, be sure to use only genuine Hitachi service parts. Using hoses other than genuine Hitachi hoses may cause oil leaks, hose rupture or Separation of fitting, possibly resulting in a fire on the machine.

Do not install hoses kinked. Application of high oil pressure, vibration, or an impact to a kinked hose may result in oil leaks, hose rupture or separation of fitting. Utilize Print marks on hoses when installing to prevent hose from being kinked.

If hoses rub against each other, wear to the hoses will result, leading to hose rupture. Take necessary measures to protect hoses from rubbing against each other.

Take care so that hoses do not come into contact with moving parts or sharp objects.

**WRONG**

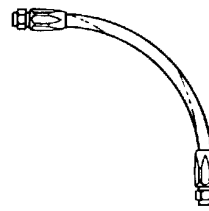

**RIGHT**

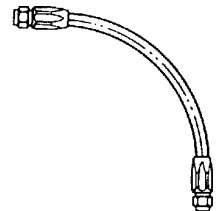

W105-01-01-011

**WRONG**

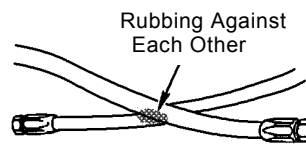

**RIGHT**

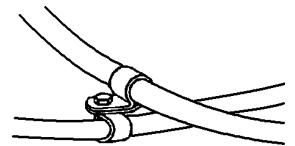

W105-01-01-012

**WRONG**

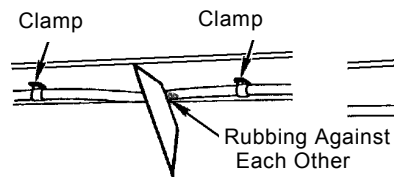

**RIGHT**

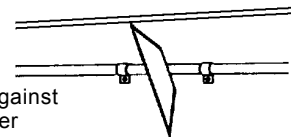

W105-01-01-013

**WRONG**

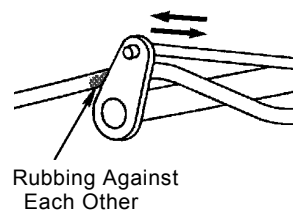

**RIGHT**

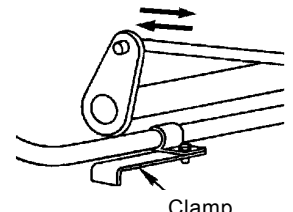

W105-01-01-014

## GENERAL / Tightening Torque

---

### PERIODIC REPLACEMENT OF PARTS

To ensure safe operation, be sure to conduct periodic inspection of the machine. In addition, the parts listed below, if defective, may pose serious safety/fire hazards. It is very difficult to gauge the extent of deterioration, fatigue, or weakening of the parts listed below simply by visual inspection alone. For this reason, replace these parts at the intervals shown in the table below. However, if any of these parts are found to be defective, replace before starting operation, regardless of the interval.

Also, when replacing hoses, check the clamps for deformation, cracks, or other deterioration, and replace as necessary.

Be sure to perform periodic inspection of all hoses, as shown below, and replace or retighten any defective parts found, as necessary.

Consult your authorized dealer for correct replacement.

Periodic Replacement Parts		Replacement Intervals	
Engine	Fuel hose (Fuel tank to filter)	Every 2 years	
	Fuel hose (Fuel tank to injection pump)	Every 2 years	
	Oil filter hose (Engine to oil filter)	Every 2 years	
	Heater hose (Heater to engine)	Every 2 years	
Hydraulic System	Base Machine	Pump suction hose	Every 2 years
		Pump delivery hose	Every 2 years
		Swing hose	Every 2 years
	Front Attachment	Boom cylinder line hose	Every 2 years
		Arm cylinder line hose	Every 2 years
		Bucket cylinder line hose	Every 2 years
		Pilot hose	Every 2 years

 **NOTE:** Be sure to replace seals, such as O-rings and gaskets, when replacing hoses.

## GENERAL / Painting

### PAINTING

Surfaces to Be Painted	Painting Colour
• Main surface of upperstructure	YR-01 [TAXI yellow]
Bed cover	High Grade Beige
Tool box cover	YR-01 [TAXI yellow]
Inner face	Grey
• Front attachment	YR01 [TAXI yellow]
• Track (undercarriage)	N1.0 [Black]
• Floor plate	M/F cation colour
• Rear left portion of cab	YR-01 [TAXI yellow]

### Final painted colour

• Inside and outside surface of cab	High Grade Beige
• Right window beam	[KASAI PAINT LF-113-230B (Charcoal series black, half glossy)]
• Suspension lifter (chair bottom)	[N2.0 (Black) ]
• Lever (Travel, lock, foot rest)	[N2.0 (Black) ]
• Engine cover	High Grade Black
• Ladder rail on right side of upperstructure	High Grade Black
• Mirror stay	High Grade Black
• Antislip cover	KASAI PAINT Amilack 1400 deep black.

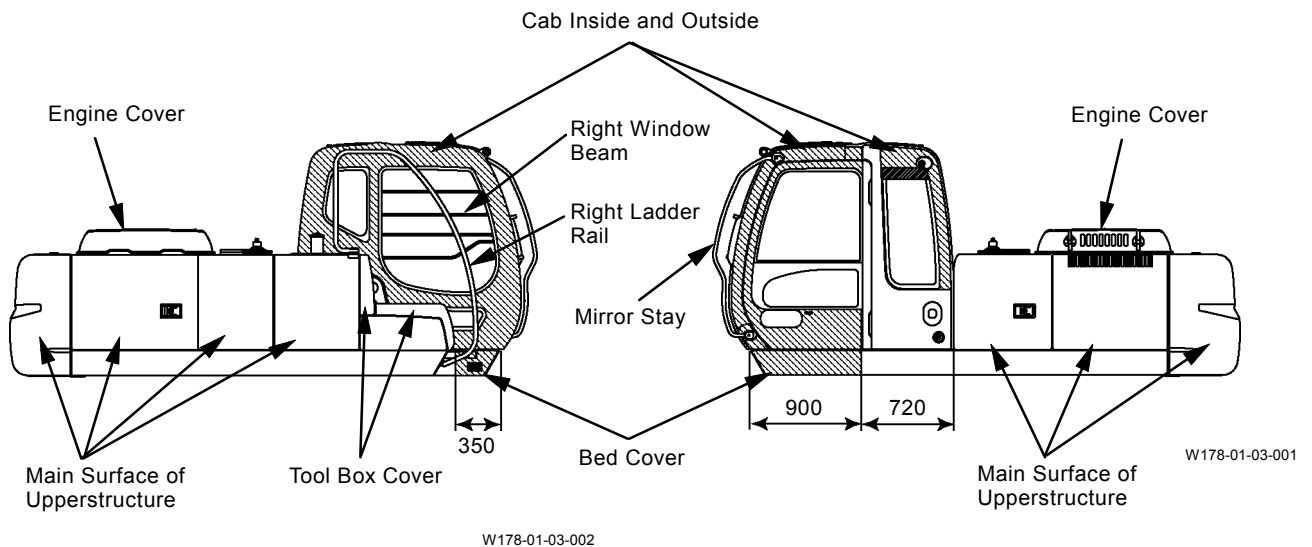

# GENERAL / Painting

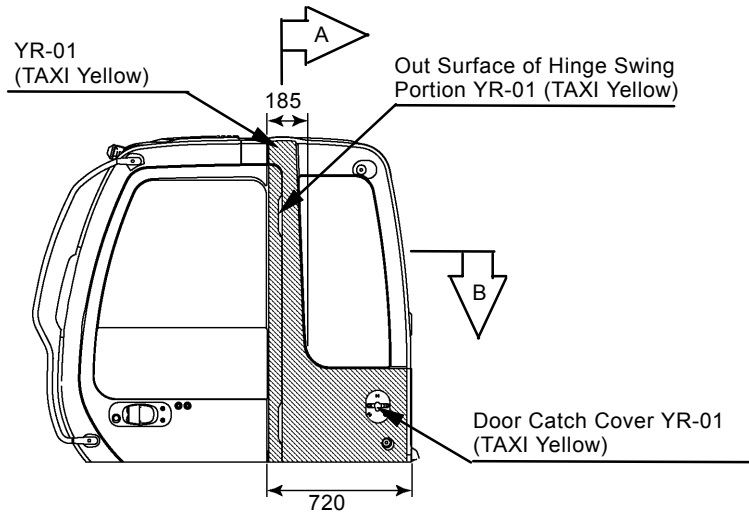

W178-01-03-003

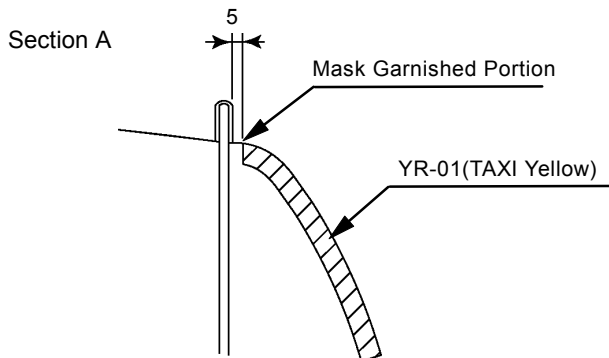

W178-01-03-004

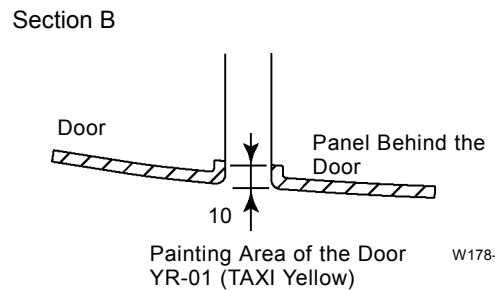

W178-01-03-005

Front Attachment YR-01 (TAXI Yellow)

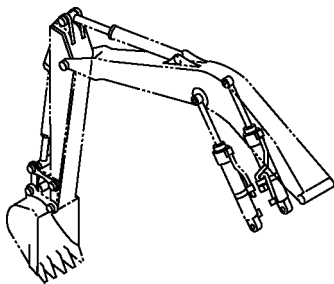

W178-01-03-007

Antislip Cover  
KASAI PAINT  
Amilack 1400  
Deep Black

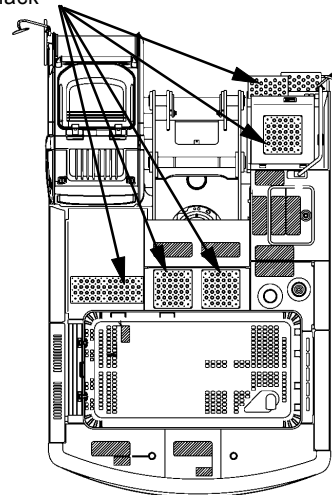

Upper Side of Frame

W1HH-01-03-001

**IMPORTANT:** When cleaning arm, cylinder, etc. fitted with HN bushing, care not to pour washing liquid directly on them. The ambient temperature shall be controlled under 70°C when painting and drying.

Track (Undercarriage)  
N1.0 (Black)

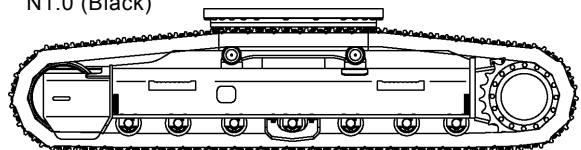

W178-01-03-008

**BUY NOW**

**Then Instant Download  
the Complete Manual  
Thank you very much!**