

Workshop Manual

ZAXIS

600

Excavator

HITACHI

SAFETY

RECOGNIZE SAFETY INFORMATION

- This is the **SAFETY ALERT SYMBOL**.
 - When you see this symbol on your machine or in this manual, be alert to the potential for personal injury.
 - Follow recommended precautions and safe operating practices.

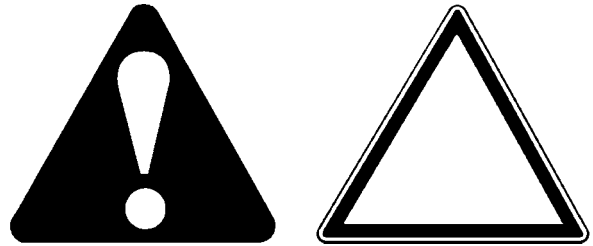

001-E01A-0688

SA-688

UNDERSTAND SIGNAL WORDS

- On machine safety signs, signal words designating the degree or level of hazard - **DANGER**, **WARNING**, or **CAUTION** - are used with the safety alert symbol.
 - **DANGER** indicates an imminently hazardous situation which, if not avoided, will result in death or serious injury.
 - **WARNING** indicates a potentially hazardous situation which, if not avoided, could result in death or serious injury.
 - **CAUTION** indicates a potentially hazardous situation which, if not avoided, may result in minor or moderate injury.
 - **DANGER or WARNING safety signs** are located near specific hazards. General precautions are listed on **CAUTION safety signs**.
 - Some safety signs don't use any of the designated signal words above after the safety alert symbol are occasionally used on this machine.
- **CAUTION** also calls attention to safety messages in this manual.
- To avoid confusing machine protection with personal safety messages, a signal word **IMPORTANT** indicates a situation which, if not avoided, could result in damage to the machine.
-  **NOTE** indicates an additional explanation for an element of information.



SA-1223

002-E01C-1223

SAFETY

FOLLOW SAFETY INSTRUCTIONS

- Carefully read and follow all safety signs on the machine and all safety messages in this manual.
- Safety signs should be installed, maintained and replaced when necessary.
 - If a safety sign or this manual is damaged or missing, order a replacement from your authorized dealer in the same way you order other replacement parts (be sure to state machine model and serial number when ordering).
- Learn how to operate the machine and its controls correctly and safely.
- Allow only trained, qualified, authorized personnel to operate the machine.
- Keep your machine in proper working condition.
 - Unauthorized modifications of the machine may impair its function and/or safety and affect machine life.
- The safety messages in this SAFETY chapter are intended to illustrate basic safety procedures of machines. However it is impossible for these safety messages to cover every hazardous situation you may encounter. If you have any questions, you should first consult your supervisor and/or your authorized dealer before operating or performing maintenance work on the machine.

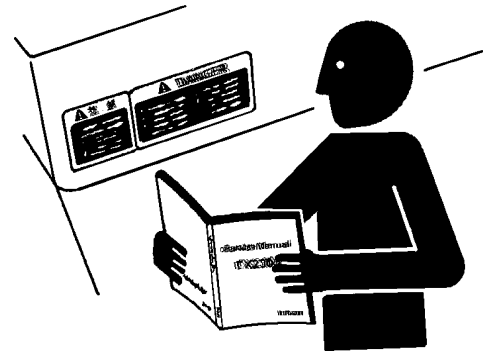

SA-003

003-E01B-0003

PREPARE FOR EMERGENCIES

- Be prepared if a fire starts or if an accident occurs.
 - Keep a first aid kit and fire extinguisher on hand.
 - Thoroughly read and understand the label attached on the fire extinguisher to use it properly.
 - To ensure that a fire-extinguisher can be always used when necessary, check and service the fire-extinguisher at the recommended intervals as specified in the fire-extinguisher manual.
 - Establish emergency procedure guidelines to cope with fires and accidents.
 - Keep emergency numbers for doctors, ambulance service, hospital, and fire department posted near your telephone.

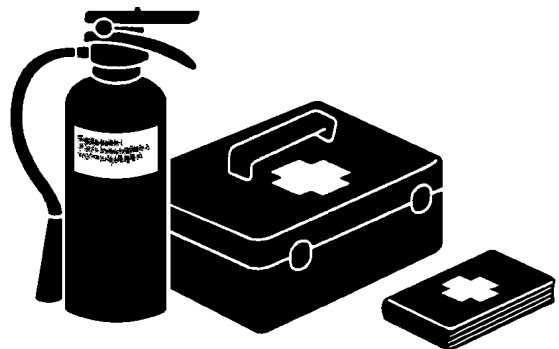

SA-437

004-E01A-0437

SAFETY

WEAR PROTECTIVE CLOTHING

- Wear close fitting clothing and safety equipment appropriate to the job.

You may need:

- A hard hat
- Safety shoes
- Safety glasses, goggles, or face shield
- Heavy gloves
- Hearing protection
- Reflective clothing
- Wet weather gear
- Respirator or filter mask.

Be sure to wear the correct equipment and clothing for the job. Do not take any chances.

- Avoid wearing loose clothing, jewelry, or other items that can catch on control levers or other parts of the machine.
- Operating equipment safely requires the full attention of the operator. Do not wear radio or music headphones while operating the machine.

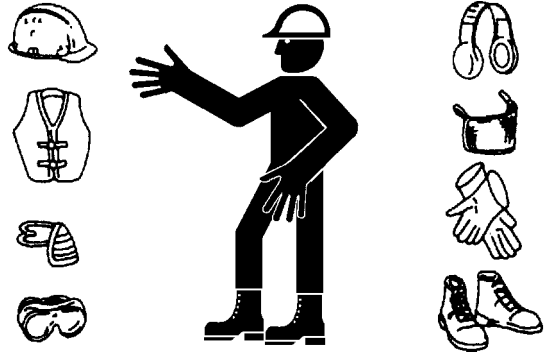

SA-438

005-E01A-0438

PROTECT AGAINST NOISE

- Prolonged exposure to loud noise can cause impairment or loss of hearing.
- Wear a suitable hearing protective device such as earmuffs or earplugs to protect against objectionable or uncomfortably loud noises.



006-E01A-0434

SA-434

INSPECT MACHINE

- Inspect your machine carefully each day or shift by walking around it before you start it to avoid personal injury.
- In the walk-around inspection be sure to cover all points described in the “PRE-START INSPECTION” chapter in the operator’s manual.



S007-E01A-0435

SA-435

SAFETY

GENERAL PRECAUTIONS FOR CAB

- Before entering the cab, thoroughly remove all dirt and/or oil from the soles of your work boots. If any controls such as a pedal is operated while with dirt and/or oil on the soles of the operator's work boots the operator's foot may slip off the pedal, possibly resulting in a personal accident.
- Don't leave parts and/or tools lying around the operator's seat. Store them in their specified locations.
- Avoid storing transparent bottles in the cab. Don't attach any transparent type window decorations on the windowpanes as they may focus sunlight, possibly starting a fire.
- Refrain from listening to the radio, or using music headphones or mobile telephones in the cab while operating the machine.
- Keep all flammable objects and/or explosives away from the machine.
- After using the ashtray, always cover it to extinguish the match and/or tobacco.
- Don't leave cigarette lighters in the cab. When the temperature in the cab increases, the lighter may explode.

524-E01A-0000

SECTION 1 GENERAL INFORMATION



CONTENTS

Group 1 Precautions for Disassembling and Assembling

Precautions for Disassembling and Assembling	W1-1-1
Maintenance Standard Terminology.....	W1-1-7

Group 2 Tightening Torque

Tightening Torque Specification.....	W1-2-1
Torque Chart	W1-2-3
Piping Joint	W1-2-6
Periodic Replacement of Parts	W1-2-10

Group 3 Painting

Painting.....	W1-3-1
---------------	--------

(Blank)

GENERAL / Precautions for Disassembling and Assembling

PRECAUTIONS FOR DISASSEMBLING AND ASSEMBLING

Precautions for Disassembling and Assembling

- Clean the Machine

Thoroughly wash the machine before bringing it into the shop. Bringing a dirty machine into the shop may cause machine components to be contaminated during disassembling/assembly, resulting in damage to machine components, as well as decreased efficiency in service work.

- Inspect the Machine

Be sure to thoroughly understand all disassembling/assembly procedures beforehand, to help avoid incorrect disassembling of components as well as personal injury.

Check and record the items listed below to prevent problems from occurring in the future.

- The machine model, machine serial number, and hour meter reading.
- Reason for disassembly (symptoms, failed parts, and causes).
- Clogging of filters and oil, water or air leaks, if any.
- Capacities and condition of lubricants.
- Loose or damaged parts.

- Prepare and Clean Tools and Disassembly Area

Prepare the necessary tools to be used and the area for disassembling work.

- Precautions for Disassembling

- To prevent dirt from entering, cap or plug the removed pipes.
- Before disassembling, clean the exterior of the components and place on a work bench.
- Before disassembling, drain gear oil from the reduction gear.
- Be sure to provide appropriate containers for draining fluids.
- Use matching marks for easier reassembly.
- Be sure to use the specified special tools, when instructed.
- If a part or component cannot be removed after removing its securing nuts and bolts, do not attempt to remove it forcibly. Find the cause(s), then take the appropriate measures to remove it.
- Orderly arrange disassembled parts. Mark and tag them as necessary.
- Store common parts, such as bolts and nuts with reference to where they are to be used and in a manner that will prevent loss.
- Inspect the contact or sliding surfaces of disassembled parts for abnormal wear, sticking, or other damage.
- Measure and record the degree of wear and clearances.

GENERAL / Precautions for Disassembling and Assembling

- Precautions for Assembling

- Be sure to clean all parts and inspect them for any damage. If any damage is found, repair or replace part.
- Dirt or debris on the contact or sliding surfaces may shorten the service life of the machine. Take care not to contaminate any contact or sliding surfaces.
- Be sure to replace O-rings, backup rings, and oil seals with new ones once they are disassembled. Apply a film of grease before installing.
- Be sure that liquid-gasket-applied surfaces are clean and dry.
- If an anti-corrosive agent has been used on a new part, be sure to thoroughly clean the part to remove the agent.
- Utilize matching marks when assembling.
- Be sure to use the designated tools to assemble bearings, bushings and oil seals.
- Keep a record of the number of tools used for disassembly/assembly. After assembling is complete, count the number of tools, so as to make sure that no forgotten tools remain in the assembled machine.

Bleeding Air from Hydraulic System

When hydraulic oil is drained, the suction filter or the suction lines are replaced, or the removal and installation of the pump, swing motor, travel motor or cylinder is done, bleed air from the hydraulic system in the following procedures:

IMPORTANT: If the engine is started with air trapped in the hydraulic pump housing, damage to the pump may result. If the hydraulic motor is operated with air trapped in the hydraulic motor housing, damage to the motor may result. If the cylinder is operated with air trapped in the cylinder tube, damage to the cylinder may result. Be sure to bleed air before starting the engine.

- Bleeding Air from Hydraulic Pump

- Remove the air bleeding plug from the top of the pump and fill the pump housing with hydraulic oil.
- After the pump housing is filled with hydraulic oil, temporarily tighten the plug. Then, start the engine and run at slow idle speed.
- Slightly loosen the plug to bleed air from the pump housing until hydraulic oil oozes out.
- After bleeding all the air, securely tighten the plug.

- Bleeding Air from Travel Motor / Swing Motor

- With the drain plug / hose on travel motor / swing motor removed, fill the motor case with hydraulic oil.

GENERAL / Precautions for Disassembling and Assembling

- Bleeding Air from Hydraulic Circuit

- After refilling hydraulic oil, start the engine. While operating each cylinder, swing motor and travel motor evenly, operate the machine under light loads for 10 to 15 minutes. Slowly start each operation (never fully stroke the cylinders during initial operation stage). As the pilot oil circuit has an air bleed device, air trapped in the pilot oil circuit will be bled while performing the above operation for approx. 5 minutes.
- Reposition the front attachment to check hydraulic oil level.
- Stop the engine. Recheck hydraulic oil level. Replenish oil as necessary.

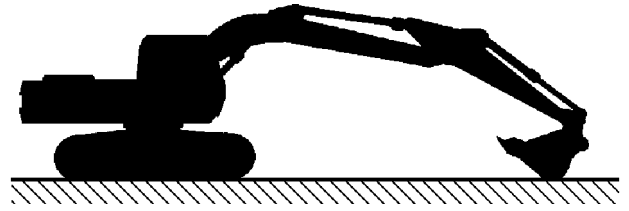

M104-07-021

GENERAL / Precautions for Disassembling and Assembling

Floating Seal Precautions

1. In general, replace the floating seal with a new one after disassembling. If the floating seal is to be reused, follow these procedures:

- (1) Keep seal rings together as a matched set with seal ring faces together. Insert a piece of cardboard to protect surfaces. Apply oil to the sliding surface (C) on seal ring (A).
- (2) Check the slide surface (C) on seal ring (A) for scuffing, scoring, corrosion, deformation or uneven wear.
- (3) Check O-ring (B) for tears, breaks, deformation or hardening.

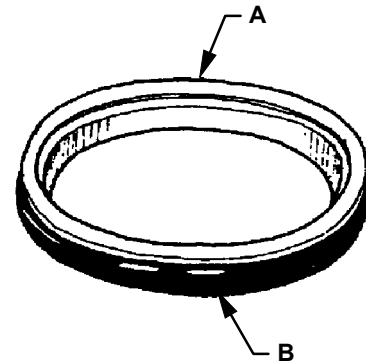

W105-03-05-019

2. If incorrectly assembled, oil leakage or damage will occur. Be sure to do the following, to prevent trouble.

- (1) Clean the floating seal and seal mounting bores with cleaning solvent. Use a wire brush to remove mud, rust or dirt. After cleaning, thoroughly dry parts with compressed air.
- (2) Clean the floating seal and seal mounting bores. Check the bore surface for scuffing or scoring by touching the surface.
- (3) Check that the O-ring is not twisted, and that it is installed correctly on the seal ring.
- (4) After installing the floating seal, check that seal ring surface (C) is parallel with seal mating face (D) by measuring the distances (C) and (D) at point (a) and (b), as illustrated. If these distances differ, correct the O-ring seating.

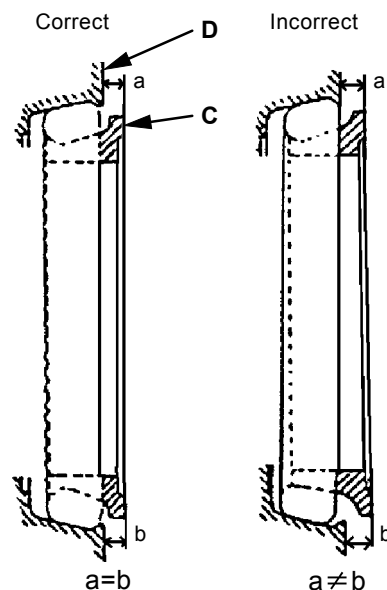
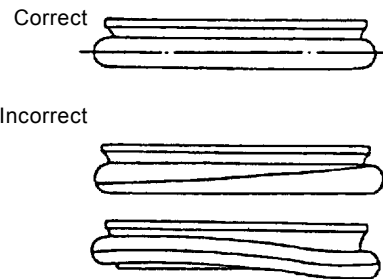
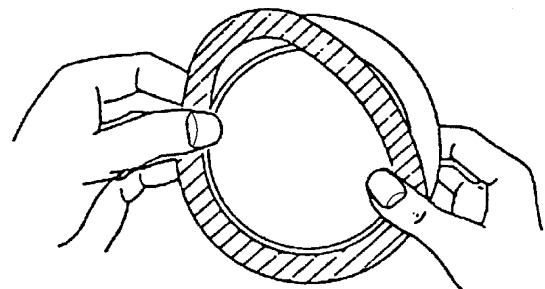

W110-03-05-020

W110-03-05-004

GENERAL / Precautions for Disassembling and Assembling

Precautions for Using Nylon Sling

1. Follow the precautions below to use nylon slings safely.
 - Attach protectors (soft material) on the corners of the load so that the nylon sling does not directly contact the corners. This will prevent the nylon sling from being damaged and the lifted load from slipping.
 - Lower the temperature of the lifted load to lower than 100 °C (212 °F). If unavoidably lifting a load with a temperature of 100 °C (212 °F) or more, reduce the load weight.
 - Do not lift acid or alkali chemicals.
 - Take care not to allow the sling to become wet. The load may slip.
 - When required to use more than one sling, use slings with the same width and length to keep the lifted load balanced.
 - When lifting a load using an eyehole, be sure to eliminate any gaps between the sling and load. (Refer to the right illustration.) Reduce the load weight so that it is less than 80 % of the sling breaking force.
 - Avoid using twisted, bound, connected, or hitched slings.
 - Do not place any object on twisted or bent slings. (Refer to the right illustration.)
 - When removing the slings from under the load, take care not to damage the nylon slings. Avoid contact with protrusions.
 - Avoid dragging slings on the ground, throwing slings or pushing slings with a metal object.
 - When using with other types of slings (wire rope) or accessories (shackle), protect the joint so that the nylon sling is not damaged.
 - Store the nylon slings indoors so they won't deteriorate with heat, sun light, or chemicals.

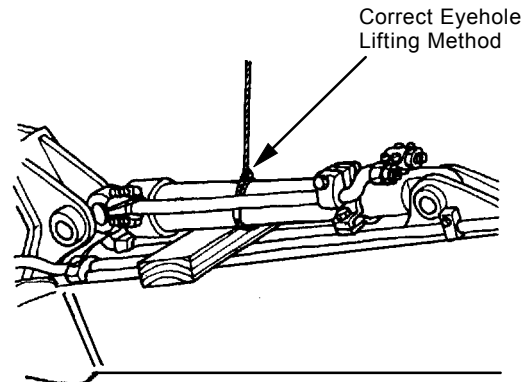

W102-04-02-016

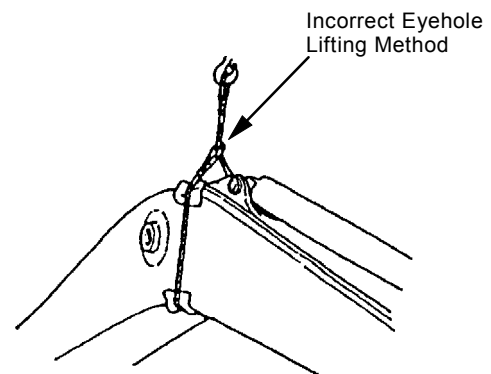

W105-04-01-008

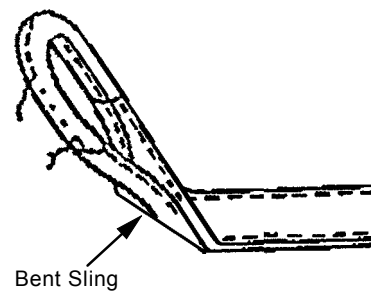

W162-01-01-009

GENERAL / Precautions for Disassembling and Assembling



CAUTION: If a load is lifted with a damaged nylon sling, serious personal injury may result. Be sure to visually check the nylon sling for any damage before using.

2. Before using a nylon sling, visually check the nylon sling for any damage corresponding to examples shown to the right. If any damage is found, cut and discard the sling. Even if no damage is found, do not use slings older than 7-years.

Damaged Appearance Broken Sewing Thread

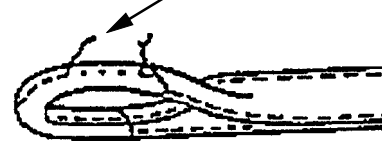

W162-01-01-002

Scuffing



W162-01-01-003

Fuzz

Broken Sewing Thread



W162-01-01-004

Broken Sewing Thread



W162-01-01-005

Broken Sewing Thread



W162-01-01-006

Scoring

Separation of Belt



W162-01-01-007

Fuzz

Scuffing

Broken Warp



W162-01-01-008

GENERAL / Precautions for Disassembling and Assembling

MAINTENANCE STANDARD TERMINOLOGY

“Standard”

1. Dimension for parts on a new machine.
2. Dimension of new components or assemblies adjusted to specification.

“Allowable Limit”

1. Normal machine performance cannot be accomplished after exceeding this limit.
2. Repair or adjustment is impossible after exceeding this limit.
3. Therefore, in consideration of operation efficiency and maintenance expense, proper maintenance shall be carried out before reaching the “Allowable Limit”.

GENERAL / Precautions for Disassembling and Assembling

(Blank)

GENERAL / Tightening Torque

TIGHTENING TORQUE SPECIFICATION

No.	Descriptions		Bolt Dia	Q'ty	Wrench Size (mm)	Torque			
			mm			N·m	(kgf·m)	(lbf·ft)	
1	Engine cushion rubber mount- ing bolt	Front	Cushion rubber - machine	22	2	32	750	(76.5)	(550)
		Rear	Cushion rubber - machine	33	2	50	1950	(198.5)	(1440)
2	Engine bracket mounting bolt		14	8	22	210	(21.5)	(155)	
3	Radiator mounting bolt		27	4	41	1050	(107.0)	(770)	
4	Hydraulic oil tank mounting bolt		16	8	24	210	(21.5)	(155)	
5	Fuel tank mounting bolt		16	8	24	210	(21.5)	(155)	
6	ORS fittings for hydraulic hoses and piping		1 - $\frac{3}{16}$ -12UNF		36	175	(18.0)	(130)	
			1 - $\frac{7}{16}$ -12UNF		41	205	(21.0)	(150)	
7	Pump transmission mounting bolt		12	14	19	110	(11.2)	(80)	
8	Main pump mounting bolt (hexagonal wrench)		20	8	17	550	(56.0)	(405)	
9	Control valve mounting bolt		20	4	30	400	(41.0)	(295)	
10	Swing device mounting bolt		22	26	32	750	(76.5)	(550)	
11	Swing motor mounting bolt (hexagonal wrench)		12	16	10	90	(9.2)	(65)	
12	Battery mounting nut		12	2	19	35	(3.5)	(25)	
13	Cab mounting nut		16	6	24	210	(21.5)	(155)	
14	Swing bearing mounting bolt to upperstructure		30	36	46	1950	(198.5)	(1440)	
	Swing bearing mounting bolt to undercarriage		30	36	46	1750	(178.0)	(1290)	
15	Travel device mounting bolt		22	48	32	750	(76.5)	(550)	
	Travel motor mounting bolt		18	8	27	300	(30.5)	(220)	
	Sprocket mounting bolt		22	48	32	750	(76.5)	(550)	
16	Upper roller mounting		20	24	30	550	(56.0)	(405)	
17	Lower roller mounting bolt		STD, H	64	36	950	(97.0)	(700)	
			LC, LCH	72	36	950	(97.0)	(700)	
18	Track shoe bolt		STD, H	392	32	1400	(143.0)	(1030)	
			LC, LCH	416	32	1400	(143.0)	(550)	
19	Track guard mounting bolt		STD, H	16	36	950	(97.0)	(700)	
			LC, LCH	24	36	950	(97.0)	(700)	
20	Track mounting bolt		33	36	50	2200	(224.0)	(1620)	

Continued on next page

GENERAL / Tightening Torque

No.	Descriptions	Bolt Dia	Q'ty	Wrench Size (mm)	Torque			
		mm			N·m	(kgf·m)	(lbf·ft)	
21	Coupling and clamp of low pressure piping	Coupling	8		13	10.5 to 12.5	(1.05 to (1.26)	(7.6 to 9.1)
		Clamp	1/4-28 UNF		11	9.8	(1.0)	(7.2)
22	Counterweight mounting bolt	45	2		65	2800	(285.5)	(2065)
		24	4		36	450	(46.0)	(330)
23	Shuttle valve mounting bolt	10	4		17	50	(5.1)	(37)
24	Front pin-retaining bolt	20	15		30	400	(41.0)	(295)
	Front pin-retaining nut	20	7		30	400	(41.0)	(295)

-  **NOTE** 1. Apply lubricant (e.g. white zinc B dissolved into spindle oil) to bolts and nuts to reduce friction coefficient of them.
2. Make sure bolt and nut threads are clean before installing.

GENERAL / Tightening Torque

TORQUE CHART

⚠ CAUTION: Use tools appropriate for the work to be done. Makeshift tools and procedures can create safety hazards. For loosening and tightening nuts and bolts, use correct size tools. Otherwise, tightening tools may slip, potentially causing personal injury.











Bolt Types

Tighten nuts or bolts correctly to torque specifications. Four different types and grades of bolt are employed. Make sure to employ correct bolts and tighten them correctly when assembling the machine or components.

SA-040

Specified Tightening Torque Chart

Bolt Dia.	Wrench Size	Hexagon Wrench Size	   <small>M552-07-091</small>			   <small>M552-07-090</small>			   <small>M157-07-225</small>					
			N·m	(kgf·m)	(lbf·ft)	N·m	(kgf·m)	(lbf·ft)	N·m	(kgf·m)	(lbf·ft)			
M6	10	5									3.3 to 4.2	(0.3 to 0.4)	(2.4 to 3.1)	
M8	13	6	30	(3.1)	(22)	20	(2.0)	(15.0)	10	(1.0)	(7.4)			
M10	17	8	65	(6.6)	(48)	50	(5.1)	(37)	20	(2.0)	(15.0)			
M12	19	10	110	(11.0)	(81)	90	(9.2)	(66)	35	(3.6)	(26.0)			
M14	22	12	180	(18.5)	(135)	140	(14.0)	(103)	55	(5.6)	(41)			
M16	24	14	270	(27.5)	(200)	210	(21.5)	(155)	80	(8.2)	(59)			
M18	27	14	400	(41.0)	(295)	300	(30.5)	(220)	120	(12.0)	(89)			
M20	30	17	550	(56.0)	(410)	400	(41.0)	(295)	170	(17.0)	(125)			
M22	32	17	750	(76.5)	(550)	550	(56.0)	(410)	220	(22.5)	(162)			
M24	36	19	950	(97.0)	(700)	700	(71.5)	(520)	280	(28.5)	(205)			
M27	41	19	1400	(143)	(1030)	1050	(107)	(770)	400	(41.0)	(295)			
M30	46	22	1950	(200)	(1440)	1450	(148)	(1070)	550	(56.0)	(410)			
M33	50	24	2600	(265)	(1920)	1950	(200)	(1440)	750	(76.5)	(550)			
M36	55	27	3200	(325)	(2360)	2450	(250)	(1810)	950	(97.0)	(700)			

GENERAL / Tightening Torque

IMPORTANT: The following items are applied to both fine and coarse pitch threads.

1. Apply lubricant (i. e. white zinc B dissolved into Spindle oil) to nuts and bolts to reduce their friction coefficients.
The plated bolts require no lubricant.
2. Torque tolerance is $\pm 10\%$.
3. Be sure to use bolts of correct length. Bolts that are too long cannot be tightened, as the bolt tip comes into contact with the bottom of the bolt hole. Bolts that are too short cannot develop sufficient tightening force.
4. The torques given in the chart are for general use only. Do not use these torques if a different torque is given for a specific application.
5. Make sure that nut and bolt threads are clean before installing.
Remove dirt or corrosion, if any.

Bolt Tightening Order

When tightening two or more bolts, tighten them alternately, as shown, to ensure even tightening.

Equally tighten upper and lower alter-

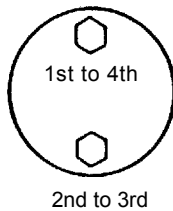

Tighten diagonally

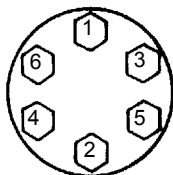

Tighten from center and diago-

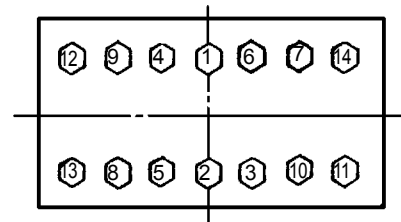

W105-01-01-003

GENERAL / Tightening Torque

Service Recommendations for Split Flange

- IMPORTANT:**
1. Be sure to clean and inspect sealing surfaces. Scratches / roughness cause leaks and seal wear. Unevenness causes seal extrusion. If defects cannot be polished out, replace the component.
 2. Be sure to use only specified O-rings. Inspect O-rings for any damage. Take care not to file O-ring surfaces. When installing an O-ring into a groove, use grease to hold it in place.
 3. While lightly tightening split flange halves, check that split is centered and perpendicular to the port. Hand-tighten bolts to hold parts in place. Take care not to pinch the O-ring.
 4. Tighten bolts alternately and diagonally, as shown, to ensure even tightening.
 5. Do not use air wrenches. Using an air wrench often causes tightening of one bolt fully before tightening of the others, resulting in damage to O-rings or uneven tightening of bolts.

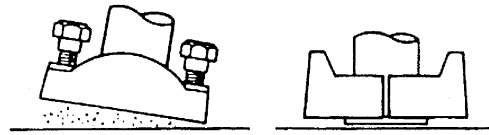

W105-01-01-015

WRONG

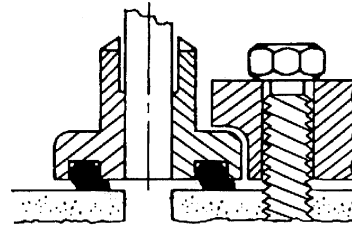

W105-01-01-016

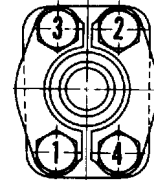

W105-01-01-008

RIGHT

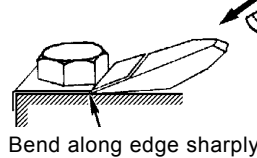

Bend along edge sharply

WRONG

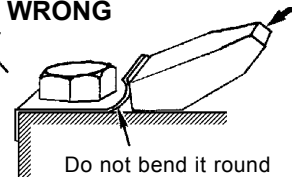

Do not bend it round

Nut and Bolt Locking

- Lock Plate

IMPORTANT: Do not reuse lock plates. Do not try to bend the same point twice.

- Cotter Pin

IMPORTANT: Do not reuse cotter pins. Match the holes in the bolt and nut while tightening, not while loosening.

- Lock Wire

IMPORTANT: Apply wire to bolts in the bolt-tightening direction, not in the bolt-loosening direction.

RIGHT

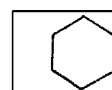

RIGHT

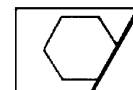

WRONG

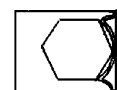

Bend along edge sharply



W105-01-01-009

RIGHT

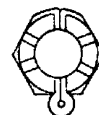

RIGHT



WRONG

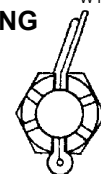

RIGHT

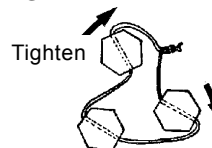

Tighten

Loosen

WRONG

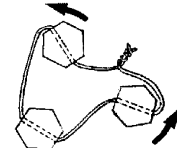

W105-01-01-010

GENERAL / Tightening Torque

PIPING JOINT

IMPORTANT: The torques given in the chart are for general use only. Do not use these torques if a different torque is given for a specific application.

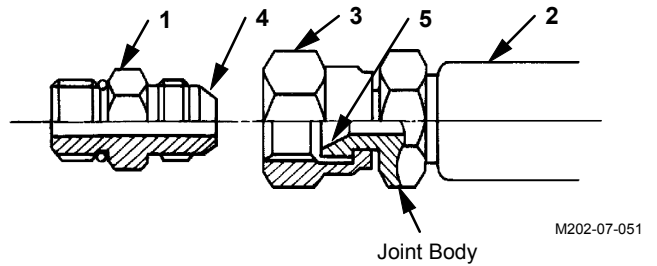

Union Joint

Metal sealing surfaces (4) and (5) of adapter (1) and hose (2) fit together to seal pressure oil. Union joints are used to join small-diameter lines.

- IMPORTANT:**
1. Do not over-tighten nut (3). Excessive force will be applied to metal sealing surfaces (4) and (5), possibly cracking adapter (1). Be sure to tighten nut (3) to specifications.
 2. Scratches or other damage to sealing surfaces (4) or (5) will cause oil leakage at the joint. Take care not to damage them when connecting/disconnecting.

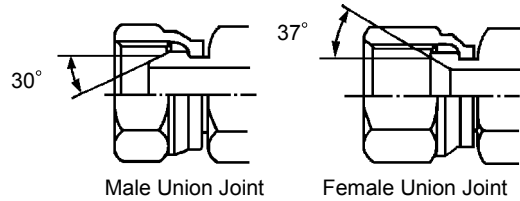

W105-01-01-017

Description	Wrench Size mm	Wrench Size mm	Tightening Torque
	Union Nut	Hose Fittings	N·m (kgf·m, lbf·ft)
30° male	17	17	24.5 (2.5,18)
	19	19	29.5 (3.0,21.5)
	22	22	39 (4.0,28.5)
	27	27	93 (9.5,69)
	32	32	137 (14.0,101)
	36	36	175 (18.0,129)
	41	41	205 (21.0,151)
37° female	17	14	24.5 (2.5,18)
	19	17	29.5 (3.0,21.5)
	22	19	39 (4.0,28.5)
	27	22	93 (9.5,69)
	32	27	137 (14.0,101)
	36	32	175 (18.0,129)
	41	36	205 (21.0,151)

NOTE: Tightening torque of 37° male coupling without union is similar to tightening torque of 37° female.

GENERAL / Tightening Torque

O-ring Seal Joint

O-ring (6) seats against the end face of adapter (7) to seal pressure oil.

- IMPORTANT:**
1. Be sure to replace O-ring (6) with a new one when reconnecting.
 2. Before tightening nut (9), confirm that O-ring (6) is seated correctly in O-ring groove (e). Tightening nut (9) with O-ring (6) displaced will damage O-ring (6), resulting in oil leakage.
 3. Take care not to damage O-ring groove (e) or sealing surface (10). Damage to O-ring (6) will cause oil leakage.
 4. If nut (9) is loose and oil is leaking, do not re-tighten nut (9). Replace O-ring (6) with a new one and check that O-ring (6) is correctly seated in place, tighten nut (9).

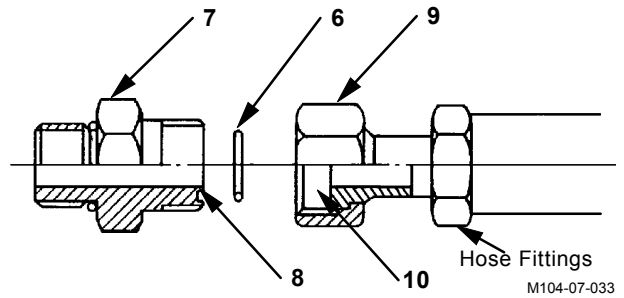

Wrench Size mm	Wrench Size mm	Tightening Torque
Union Nut	Hose Fittings	N-m (kgf-m, lbf-ft)
19	17	29.5 (3.0,21.5)
22	19	69 (7.0,51)
27	22	93 (9.5,69)
32	27	137 (14.0,101)
36	30,32	175 (18.0,129)
41	36	205 (21.0,151)
46	41	205 (21.0,151)

GENERAL / Tightening Torque

Screw-In Connection

Depending on types of screw and sealing, different types of screw fittings are used.

IMPORTANT: Be sure to confirm that the thread pitch and thread type (tapered or straight) are the correct type before using any screw-in connection.

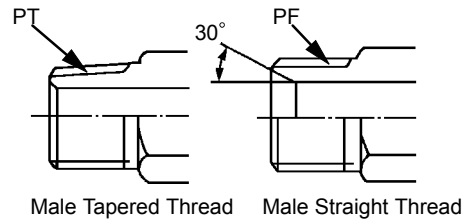

W105-01-01-018

Male Tapered Thread		
Wrench Size mm	Tightening Torque N·m (kgf·m, lbf·ft)	
	FC material	SS material
Hose Fittings		
19	14.5 (1.5,10.5)	34 (3.5,25)
22	29.5 (3.0,21.5)	49 (5.0,36)
27	49 (5.0,36)	93 (9.5,69)
36	69 (7.0,51)	157 (16,116)
41	108 (11,80)	205 (21,151)
50	157 (16,116)	320 (33,235)
60	195 (20,144)	

Seal Tape Application

Seal tape is used to seal clearances between male and female threads, so as to prevent any leaks between threads.

Be sure to apply just enough seal tape to fill up thread clearances. Do not overwrap.

- Application Procedure

Confirm that the thread surface is clean and, free of dirt or damage.

Apply seal tape around threads as shown. Wrap seal tape in the same direction as the threads.

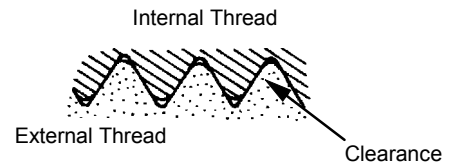

W105-01-01-019

Low-Pressure-Hose Clamp Tightening Torque

Low-pressure-hose clamp tightening torque differs depending on the type of clamp.

T-Bolt Type Band Clamp:

4.4 N·m (0.45 kgf·m, 3.25 lbf·ft)

Worm Gear Type Band Clamp:

5.9 to 6.9 N·m (0.6 to 0.7 kg·m, 4.3 to 5.1 lbf·ft)

Leave one to two pitch threads uncovered

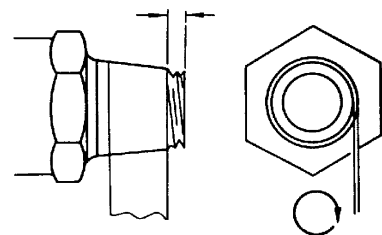

M114-07-041

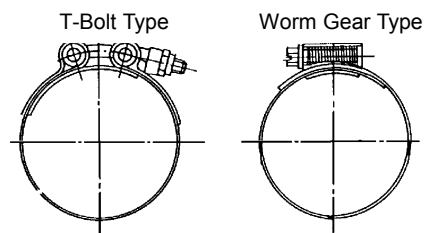

M114-07-043

M114-07-042

GENERAL / Tightening Torque

Connecting Hose



CAUTION: When replacing hoses, be sure to use only genuine Hitachi service parts. Using hoses other than genuine Hitachi hoses may cause oil leaks, hose rupture or Separation of fitting, possibly resulting in a fire on the machine.

Do not install hoses kinked. Application of high oil pressure, vibration, or an impact to a kinked hose may result in oil leaks, hose rupture or separation of fitting. Utilize Print marks on hoses when installing to prevent hose from being kinked.

If hoses rub against each other, wear to the hoses will result, leading to hose rupture. Take necessary measures to protect hoses from rubbing against each other.

Take care so that hoses do not come into contact with moving parts or sharp objects.

WRONG

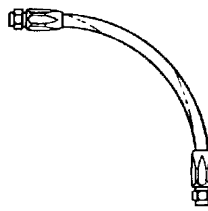

RIGHT

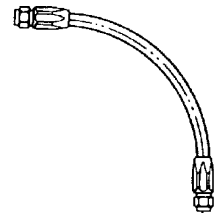

W105-01-01-011

WRONG

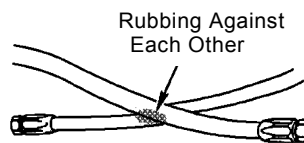

RIGHT

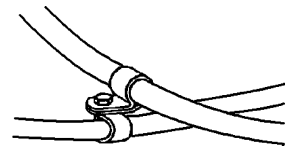

W105-01-01-012

WRONG

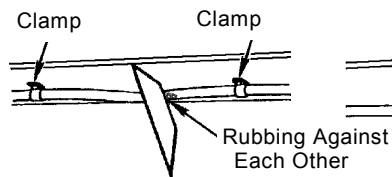

RIGHT

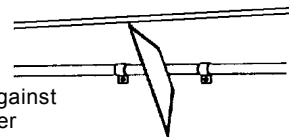

W105-01-01-013

WRONG

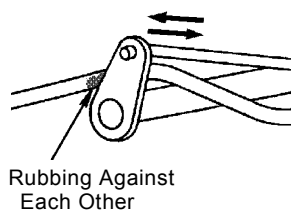

RIGHT

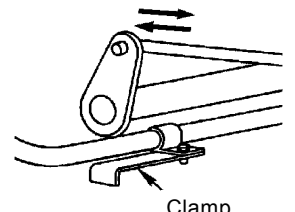

W105-01-01-014

GENERAL / Tightening Torque

PERIODIC REPLACEMENT OF PARTS

To ensure safe operation, be sure to conduct periodic inspection of the machine. In addition, the parts listed below, if defective, may pose serious safety/fire hazards. It is very difficult to gauge the extent of deterioration, fatigue, or weakening of the parts listed below simply by visual inspection alone. For this reason, replace these parts at the intervals shown in the table below. However, if any of these parts are found to be defective, replace before starting operation, regardless of the interval.

Also, when replacing hoses, check the clamps for deformation, cracks, or other deterioration, and replace as necessary.

Be sure to perform periodic inspection of all hoses, as shown below, and replace or retighten any defective parts found, as necessary.

Consult your authorized dealer for correct replacement.

Periodic Replacement Parts		Replacement Intervals	
Engine	Fuel hose (Fuel tank to filter)	Every 2 years or Every 6000 hours	
	Fuel hose (Fuel tank to injection pump)	Every 2 years or Every 6000 hours	
	Heater hose (Heater to engine)	Every 2 years or Every 6000 hours	
Hydraulic System	Basic Machine	Pump suction hose	Every 2 years or Every 6000 hours
		Pump delivery hose	Every 2 years or Every 6000 hours
		Swing hose	Every 2 years or Every 6000 hours
		Travel hose	Every 2 years or Every 6000 hours
	Front-End Attachment	Boom cylinder line hose	Every 2 years or Every 6000 hours
		Arm cylinder line hose	Every 2 years or Every 6000 hours
		Bucket cylinder line hose	Every 2 years or Every 6000 hours
	Pilot hose	Every 2 years or Every 6000 hours	

 **NOTE:** Be sure to replace seals, such as O-rings and gaskets, when replacing hoses.

GENERAL / Painting

PAINTING

Painting specification

Surfaces to Be Painted	Painting Colour
• Main surface of upperstructure	YR-01 [TAXI yellow]
Bed cover	High Grade Beige
Inner face	Grey
Front left step, rear left step	High Grade Black
Radiator front duct	High Grade Black (Flyscreen: Grey (lacquer))
Handle of Upperstructure	High Grade Black
• Front attachment	YR-01 [TAXI yellow]
• Track (undercarriage)	N1.0 [Black]
• A part of rear left of cab	YR-01 [TAXI yellow]

Final painted colour

• Inside and outside surface of cab	High Grade Beige
• Right window beam, U-Bolt	[KASAI PAINT LF-113-230B (Charcoal series black, half glossy)]
• Suspension lifter (chair bottom)	[N2.0 (Black)]
• Lever (Travel, lock, foot rest)	[N2.0 (Black)]
• Floor plate	Grey [Cation]
• Grid plate	Deep Black
• Handle and ladder	High Grade Black

Specified masked position

• Engine plate	• Angle sensor plate
• Control valve plate	• Engine cover catch
• Swing motor plate	• Battery cable terminal cover
• Pump plate	• Air cleaner indicator

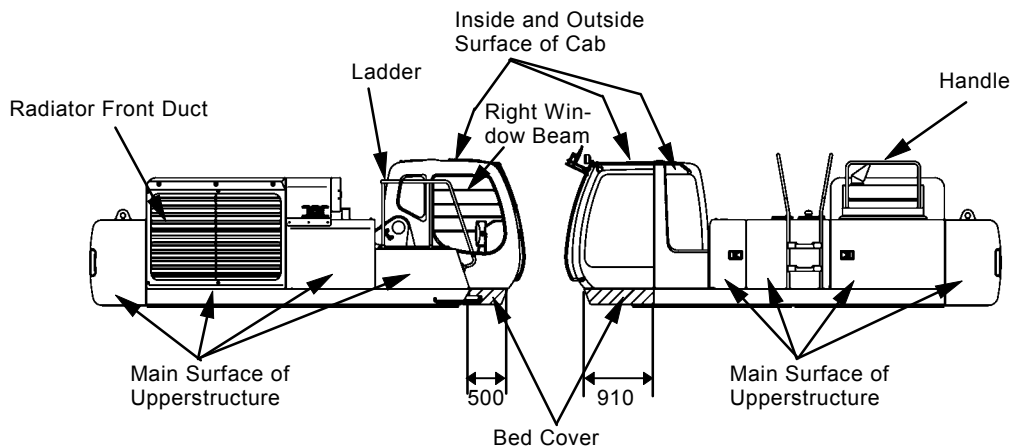

W17P-01-03-002

GENERAL / Painting

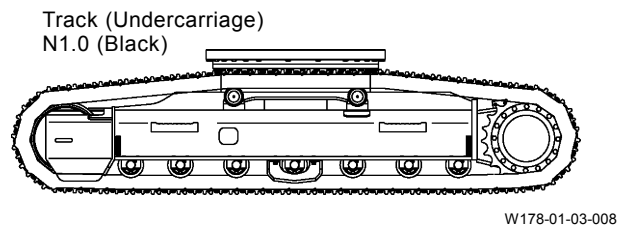
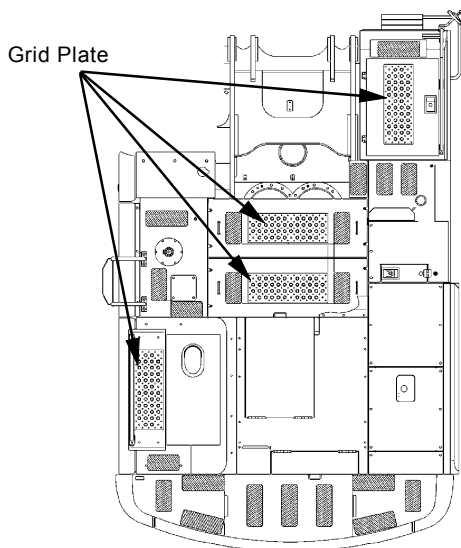
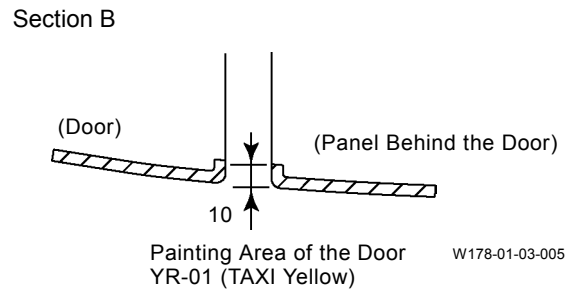
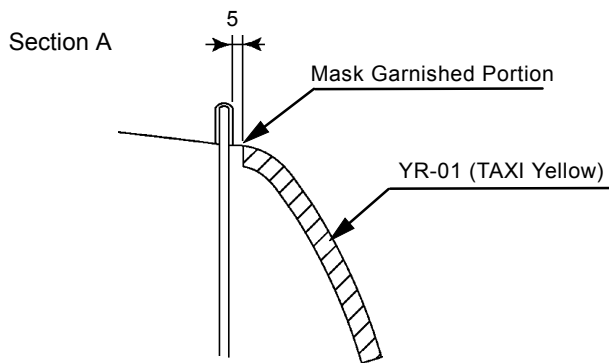
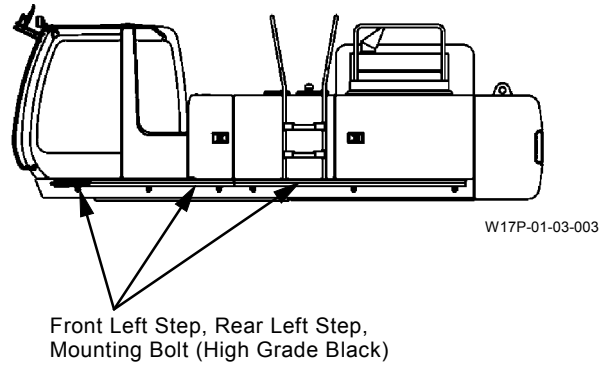
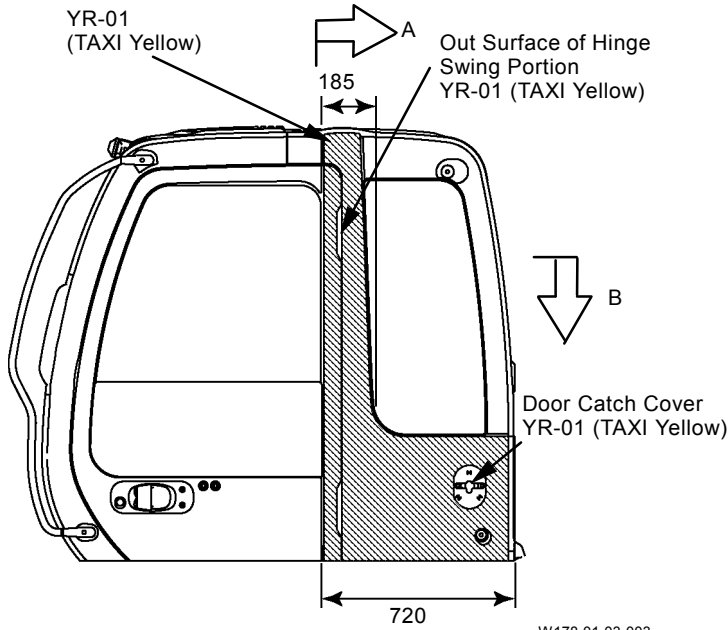

IMPORTANT: When cleaning arm, cylinder, etc. fitted with HN bushing, be sure not to pour washing liquid directly on them. The ambient temperature shall be controlled under 70 °C (158 °F) when painting and drying.

SECTION 2 UPPERSTRUCTURE

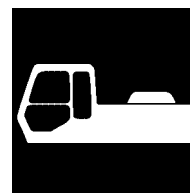

CONTENTS

Group 1 Cab

Remove and Install Cab.....	W2-1-1
Dimensions of the Cab Glass.....	W2-1-7
Remove and Install Cab Glass.....	W2-1-9

Group 2 Counterweight

Remove and Install Counterweight	W2-2-1
Remove and Install Counterweight (with Counterweight Removal Device) .	W2-2-3

Group 3 Main Frame

Remove and Install Main Frame	W2-3-1
-------------------------------------	--------

Group 4 Pump Device

Remove and Install Pump Device	W2-4-1
Disassemble Pump Transmission.....	W2-4-6
Assemble Pump Transmission	W2-4-8
Disassemble Main Pump	W2-4-10
Assemble Main Pump	W2-4-14
Maintenance Standard	W2-4-18
Disassemble Regulator	W2-4-20
Assemble Regulator.....	W2-4-22
Disassemble and Assemble Pilot Pump	W2-4-24

Group 5 Control Valve

Remove and Install Control Valve	W2-5-1
Disassemble Control Valve (5-Spool Section).....	W2-5-4
Assemble Control Valve (5-Spool Section).....	W2-5-10
Disassemble Control Valve (4-Spool Section).....	W2-5-16
Assemble Control Valve (4-Spool Section).....	W2-5-22

Disassemble Control Valve (Side Section)	W2-5-28
Assemble Control Valve (Side Section)	W2-5-32
Disassemble Housing	W2-5-34
Assemble Housing.....	W2-5-36
Disassemble Manifold	W2-5-38
Assemble Manifold	W2-5-40

Group 6 Swing Device

Remove and Install Swing Device	W2-6-1
Disassemble Swing Device	W2-6-4
Assemble Swing Device	W2-6-12
Disassemble Swing Motor	W2-6-20
Assemble Swing Motor	W2-6-24
Maintenance Standard.....	W2-6-28

Group 7 Pilot Valve

Remove and Install Pilot Valve	W2-7-1
Disassemble Right and Left Pilot Valves	W2-7-8
Assemble Right and Left Pilot Valves ...	W2-7-12
Disassemble Travel Pilot Valve.....	W2-7-16
Assemble Travel Pilot Valve	W2-7-20

Group 8 Pilot Shut-Off Valve

Remove and Install Pilot Shut-Off Valve	W2-8-1
Disassemble and Assemble Pilot Shut-Off Valve	W2-8-3

Group 9 Solenoid Valve

- Remove and Install Solenoid Valve..... W2-9-1
- Disassemble and Assemble
 - Three-Spool Solenoid Valve W2-9-4
- Disassemble and Assemble Swing Preference Circuit Shift Solenoid Valve..... W2-9-5

Group 10 Signal Control Valve

- Remove and Install Signal Control Valve..... W2-10-1

Group 11 Shockless Valve

- Remove and Install Shockless Valve ... W2-11-1
- Disassemble and Assemble
 - Shockless Valve W2-11-3

BUY NOW

**Then Instant Download
the Complete Manual
Thank you very much!**