

STEERING SYSTEM

GENERAL

There are two different steering systems available: Power Steering and Power Steering with On-Demand. The difference in the components for each system can be found in FIGURE 1. Also see FIGURE 2. This section covers the description, disassembly, assembly, checks and adjustments and the troubleshooting of the steering system. There is a description for each part of the steering system at the beginning of each repair section. On units with three wheels, the steering system turns the Master Drive Unit (MDU) to steer the lift truck. On units that have four wheels and a steering axle, the steering system operates the steering cylinder to steer the lift truck.

Additional information for the components of the steering system is found in the following sections:

MASTER DRIVE UNIT, 630 SRM 363, contains the description and repair of the MDU for the A1.00-1.5XL (A20-30XL).

THE STEERING AXLE section is different for different models. See the Table Of Contents of the **SERVICE MANUAL** for your unit to find the correct section.

THE STEERING CONTROL UNIT section is different for different models. See the Table Of Contents of the **SERVICE MANUAL** for your unit to find the correct section.

A modification has been made in the manifold assembly of the steering control unit used in the A1.00-1.50XL (A20-30XL) trucks that is different than the unit described in **THE STEERING CONTROL UNIT, 1600 SRM 54**. The four hydraulic ports are in the bottom of the steering control unit. These ports connect to the four hydraulic hoses for the steering system. The four hydraulic ports on the side of the steering control unit are not used.

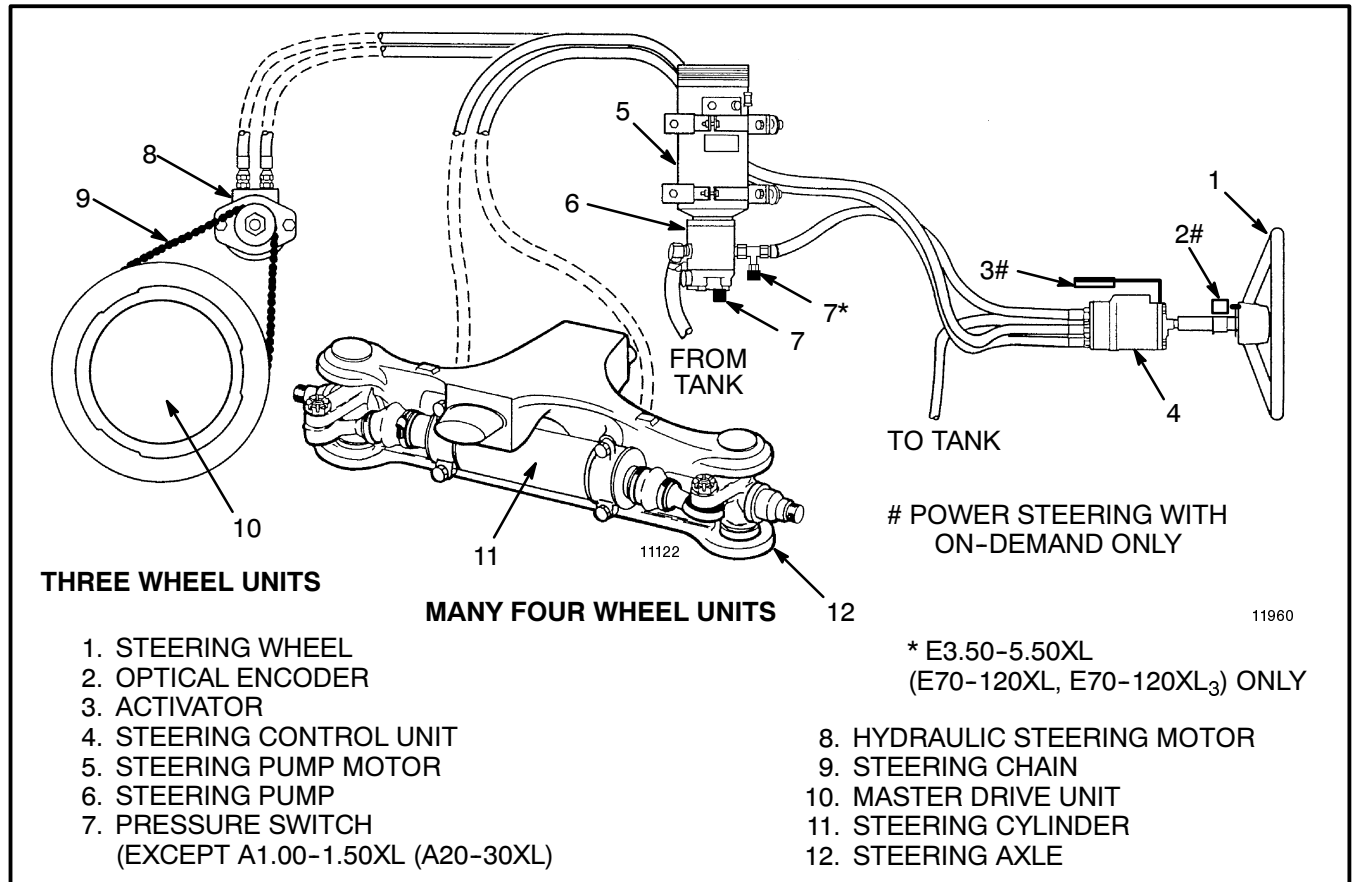
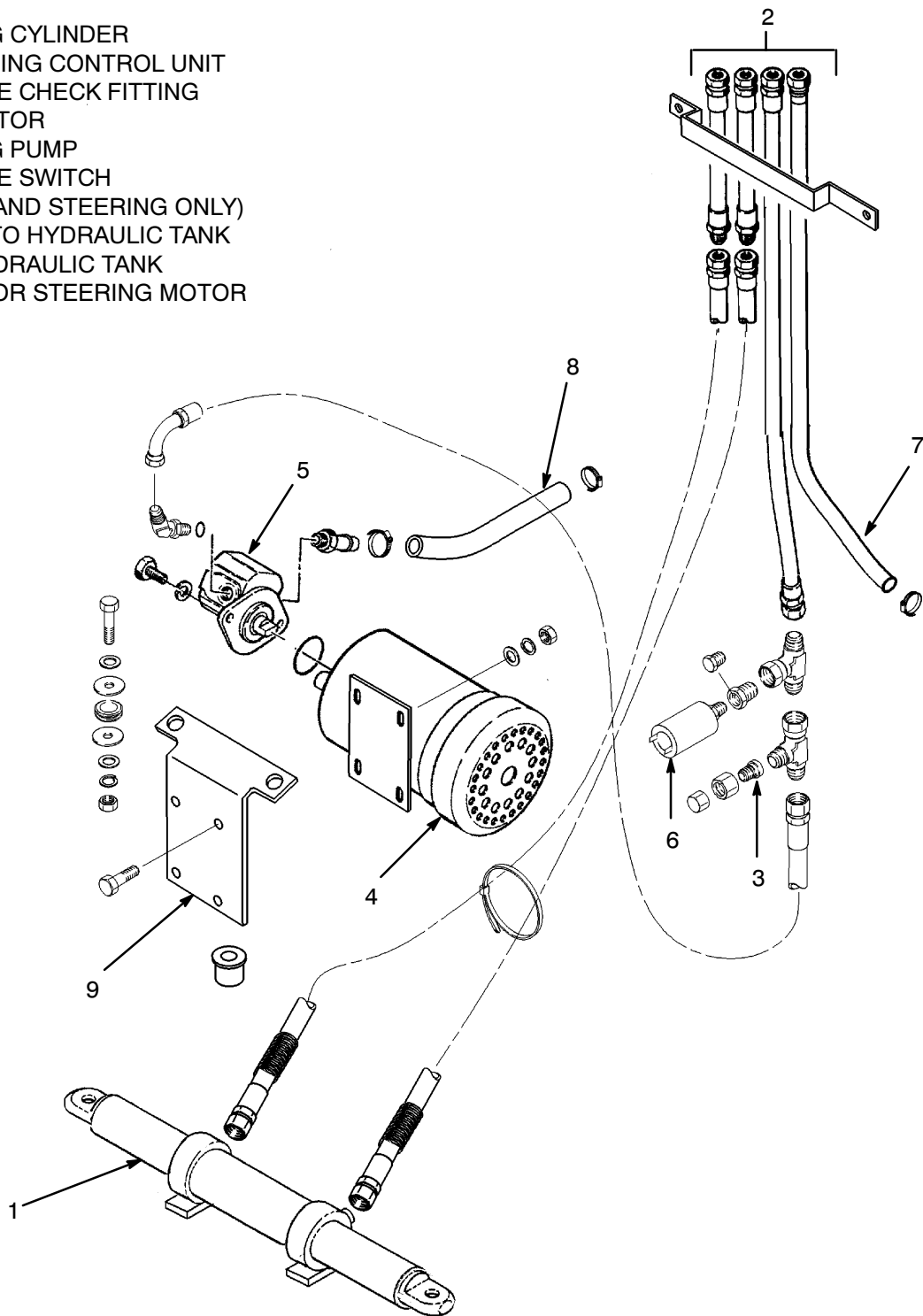

FIGURE 1. POWER STEERING COMPONENTS

1. STEERING CYLINDER
2. TO STEERING CONTROL UNIT
3. PRESSURE CHECK FITTING
4. PUMP MOTOR
5. STEERING PUMP
6. PRESSURE SWITCH
(ON-DEMAND STEERING ONLY)
7. RETURN TO HYDRAULIC TANK
8. FROM HYDRAULIC TANK
9. MOUNT FOR STEERING MOTOR



906043700
1/3 Rev 1

FIGURE 2. POWER STEERING COMPONENTS, E1.50-2.00XMS (E25-40XMS)

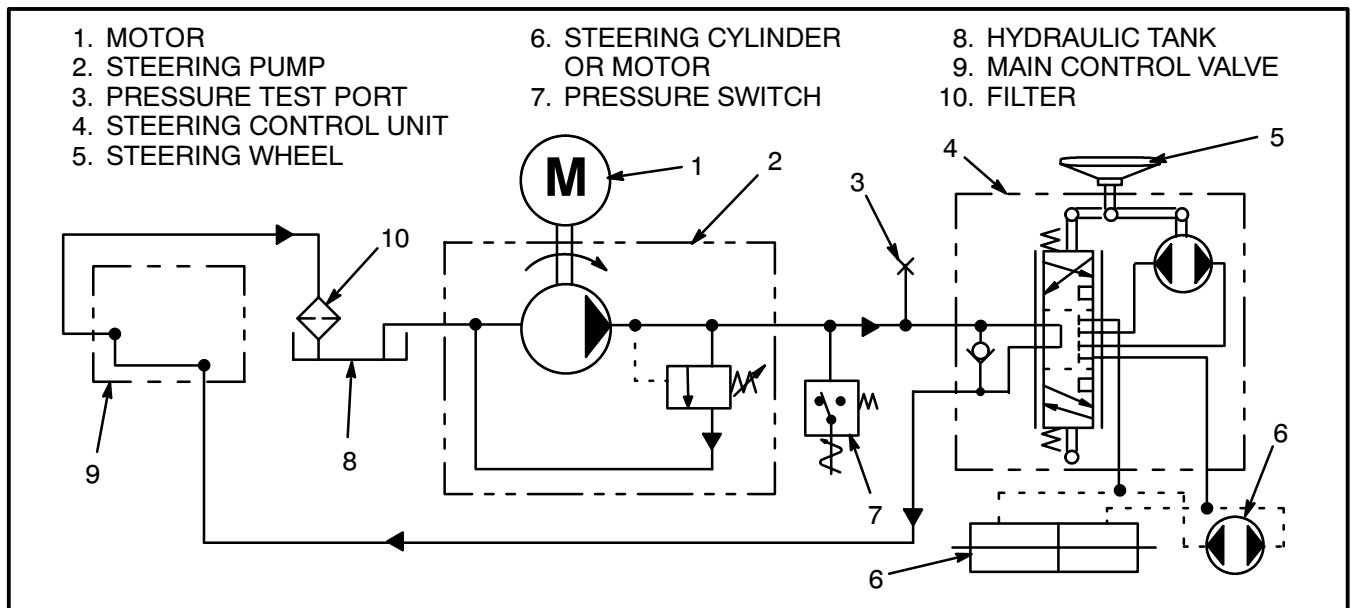

FIGURE 3. STEERING SYSTEM HYDRAULIC SCHEMATIC

DESCRIPTION

(See FIGURE 1. and FIGURE 3.)

The steering system used on these lift trucks is a hydraulic system that does not have a mechanical connection between the steering wheel and the MDU or steering axle. The control of the steering is through a hydraulic circuit. An electric motor drives a hydraulic pump. To energize the motor, the key switch must be “ON” and the seat switch must be closed. When the key switch is *first* moved to the “ON” position, forward or reverse direction must also be selected for the steering system to operate. After the starting sequence is completed, the electric motor on the Power Steering pump will run continuously. The pump motor with the On-Demand system will operate only when the steering wheel is turned. When the electric motor operates the pump, hydraulic oil flows through the power steering system.

When the steering wheel is rotated to steer the lift truck, the hydraulic oil is routed to the steering motor at the MDU or to the steering cylinder on units with a steering axle. There is a delay between the last rotation of the steering wheel and the system deenergizing in the Power Steering with On-Demand system. This delay keeps the system operating when the operator is not turning the steering wheel during straight travel. The delay is approximately one second on some truck models to between 4 and 5 seconds on other models.

A gear on the shaft of the steering wheel drives the gear of the optical encoder as the steering wheel is moved to steer the lift truck. The optical encoder sends a signal to the activator. The activator completes the battery negative circuit for the steering contactor to energize the steering pump motor. See FIGURE 4. (1 of 3) and FIGURE 16. for the electrical connections for Power Steering with the On-Demand system. Also see the **DIAGRAMS** section for your unit. The steering control unit is also operated by the steering wheel to direct oil to the steering cylinder or hydraulic motor.

NOTE: On units with a steering axle, there is a pressure switch in the hydraulic circuit. Anytime the system is operational and the system pressure is above 2.07 kPa (300 psi) the switch energizes the contactor for the steering pump motor. This pressure switch allows the system to continue to operate even if the steering wheel is not moving.

Units that have On-Demand steering have an optical encoder circuit. A gear on the shaft of the steering wheel moves the gear of the optical encoder when the steering wheel is moved. See page 1 of 3 and 3 of 3 for FIGURE 4. The optical encoder sends a signal to the activator assembly. The activator assembly completes the battery negative circuit for the steering contactor to energize the steering pump motor. The steering wheel also operates the steering control unit. When the steering wheel is rotated to steer the lift truck, the hydraulic oil is sent to the steering cylinder on the steering axle.

The steering control unit is a rotary valve operated by the steering wheel. During the steering operation, the steering control unit controls the direction of flow and volume of oil to control the direction and degree of turn. On units with an MDU, the hydraulic motor has a sprocket on the output shaft that rotates the MDU by a steering chain. On units that have a steer axle, the steering cylinder moves the steering linkage to move the steer wheels. Hydraulic oil returns from the hydraulic motor or cylinder to the steering control unit and then returns to the hydraulic tank.

If for any reason the steering pump does not operate, a check valve permits the steering control unit to still control the steering system. The lift truck is difficult to steer when the steering pump is not operating, but the steering control unit can operate the hydraulic motor or steering cylinder and makes steering possible.

STEERING WHEEL AND COLUMN ASSEMBLY (See FIGURE 4.)

The upper end of the steering shaft has splines for the steering wheel. A nut holds the steering wheel onto the steering shaft. The horn button is the cover for the center of the steering wheel. The lower end of the steering shaft has splines or a tang to engage the steering control unit. A push rod allows the horn button to actuate the horn switch.

The steering column is adjustable and is held in position by a latch. The steering column position can be changed for different operators. The steering column must be raised to the **UP** position to provide clearance for the seat when removing or installing the battery. There is a cover on the steering column for access to the steering control unit, key switch, horn switch, direction switch (if installed), optical encoder and on some units, the activator. The activator on many of the “XM” units is under the instrument panel to the left of steering column.

Removal Of The Assembly Components

NOTE: This procedure is for the removal of all components of the steering column assembly. Usually it is not necessary to remove all of the components. Do only those steps of the procedure necessary to remove the component you need to remove.

1. Disconnect the battery and attach a tag on the truck battery connector stating “DO NOT CONNECT BATTERY”. Raise the steering column to the **UP** position. Remove the access cover from the steering column.
2. Remove the the housing of the steering column. Remove key switch. Make an identification of the electrical wires and disconnect them from the key switch. Disconnect the plug from the display panel if installed.
3. If installed, remove the handle, boot, and nut that fastens the direction switch. Remove the direction switch from the housing of the steering column. Make an identification of the electrical wires and disconnect them from the direction switch.
4. Remove the capscrew that fastens the bracket for the horn switch to the housing of the steering column. Move the horn switch and bracket away from the steering column.
5. Remove the horn cover, snap ring and base plate (not part of Petri steering wheel). Lift the push rod and adjuster spool out the top of the steering shaft. Remove the nut and remove the steering wheel from the shaft. A puller makes removal of the steering wheel easier, but not all steering wheels have puller holes.
6. If the lift truck has On-Demand steering, remove the optical encoder and activator and the brackets. See FIGURE 4. (1 of 3). See FIGURE 4. (3 of 3). Make an identification of the electrical wires and disconnect them from the assemblies.
7. Make an identification of the hydraulic hoses at the steering control unit so that they can be connected correctly during assembly. Some hoses have swivel fittings to permit disconnecting at the steering control unit. Disconnect the other hoses at the base of the cowl, the control valve or the steering pump. Remove all mounting clamps so that the hoses will turn freely and not become twisted. Disconnect the hydraulic hoses at the bottom of the steering control unit. Install plugs at all hose ports and hoses to prevent dirt from entering the system.
8. Remove the capscrews, lock washers and lock plates that fasten the steering column to the pivots on the lift truck. Remove the steering column from the lift truck. Make sure the electrical wires and the hydraulic hoses are not damaged as the steering column is removed.

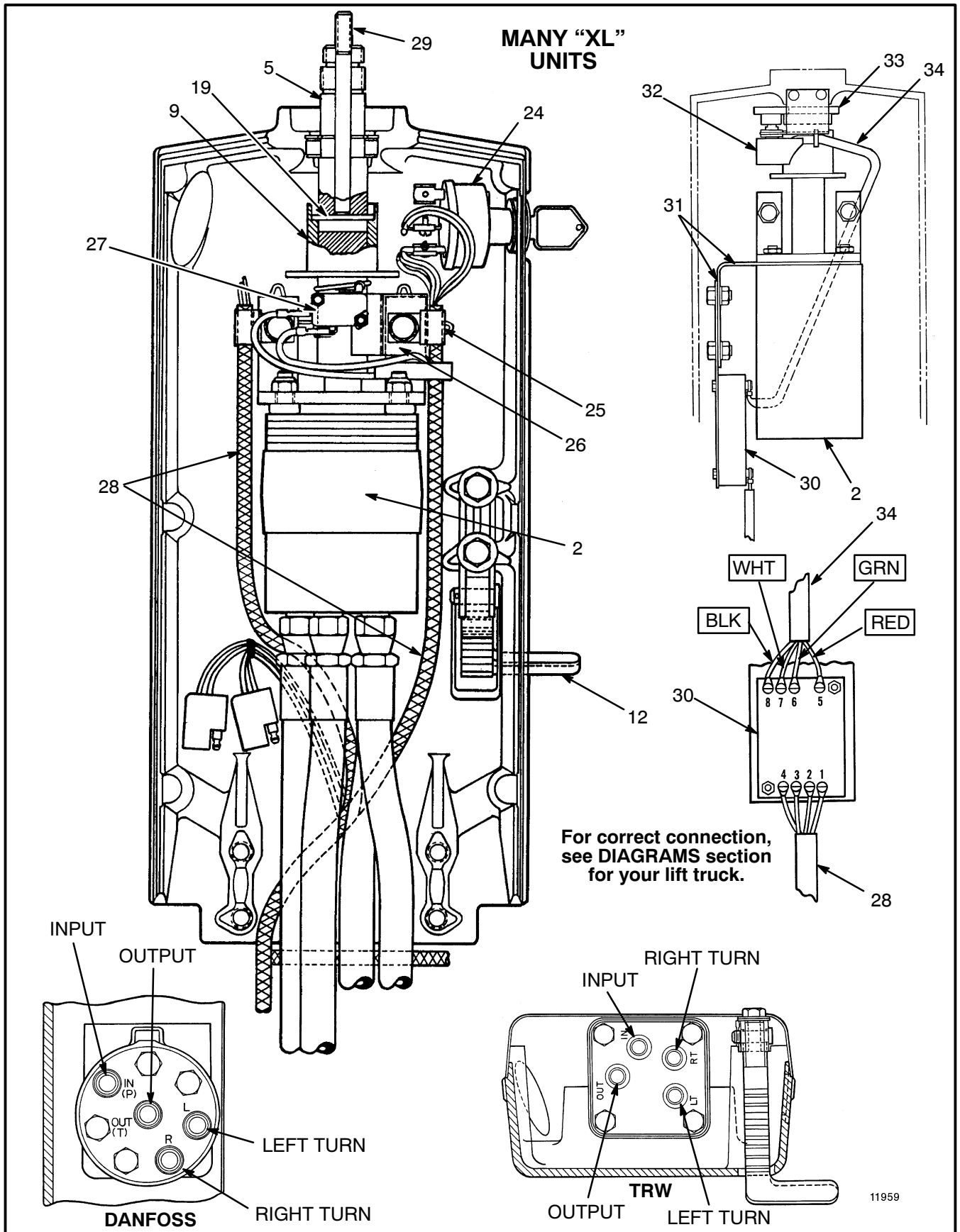
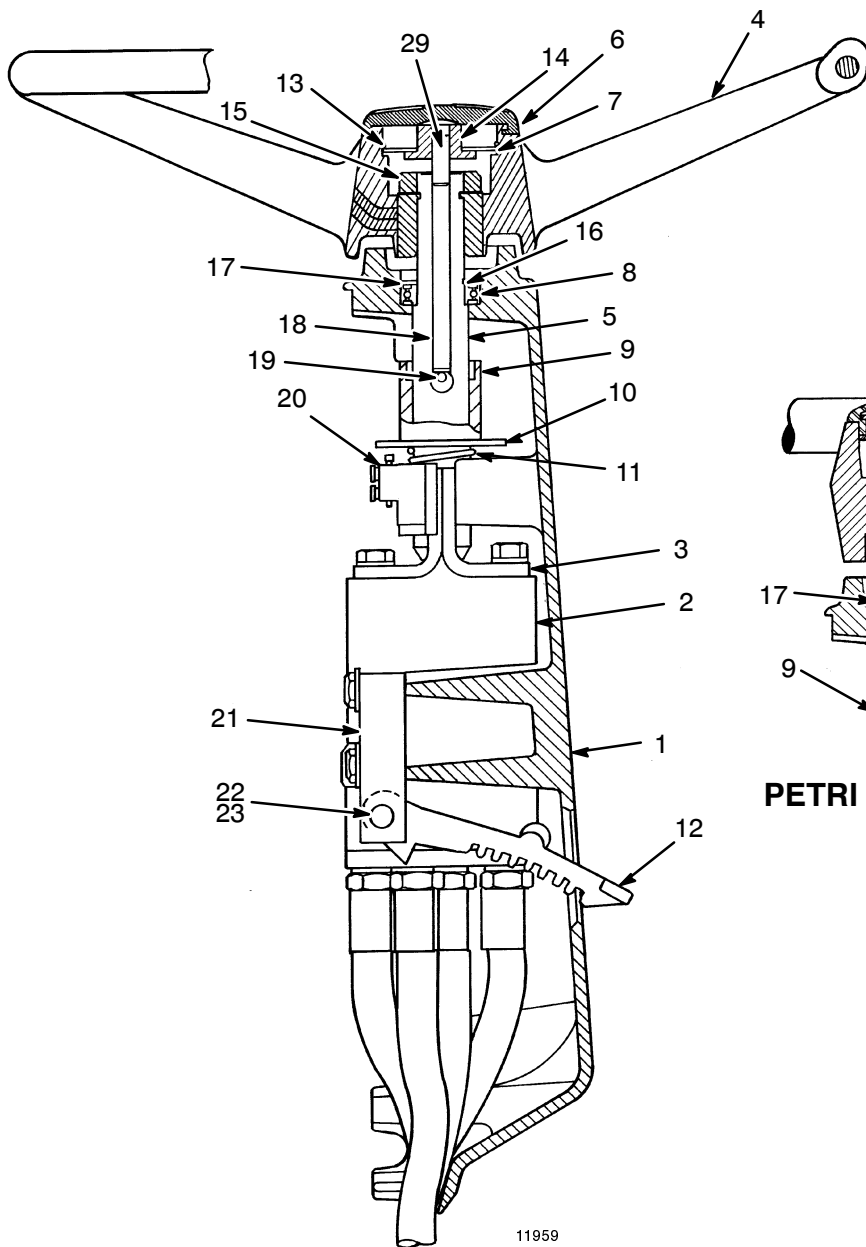
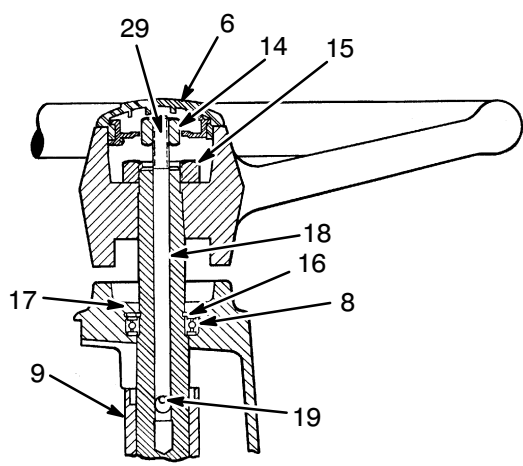

FIGURE 4. STEERING WHEEL AND STEERING COLUMN ASSEMBLY (1 of 3)



**OTHER
"XL" UNITS**



PETRI STEERING WHEEL

Legend for 1 & 2 of 3

- | | | |
|--------------------------|------------------------|------------------------------------|
| 1. STEERING COLUMN | 11. SPRING | 21. BRACKET |
| 2. STEERING CONTROL UNIT | 12. LATCH | 22. LATCH PIVOT PIN |
| 3. BRACKET | 13. LOCK RING | 23. COTTER PIN |
| 4. STEERING WHEEL | 14. ADJUSTER SPOOL NUT | 24. KEY SWITCH |
| 5. STEERING SHAFT | 15. STEERING WHEEL NUT | 25. CLAMP |
| 6. HORN COVER | 16. EXTERNAL SNAP RING | 26. BRACKET |
| 7. BASE PLATE | 17. INTERNAL SNAP RING | 27. SNAP RING |
| 8. BEARING | 18. PUSH ROD | 28. TRUCK WIRE HARNESS |
| 9. PLASTIC TUBE | 19. PIN | 29. SOCKET HEAD SCREW |
| 10. PLASTIC WASHER | 20. HORN SWITCH | 30. ACTIVATOR |
| | | 31. BRACKET |
| | | 32. OPTICAL ENCODER AND BRACKET |
| | | 33. DRIVE GEAR AND SET SCREW |
| | | 34. ENCODER/ACTIVATOR WIRE HARNESS |

FIGURE 4. STEERING WHEEL AND STEERING COLUMN ASSEMBLY (2 of 3)

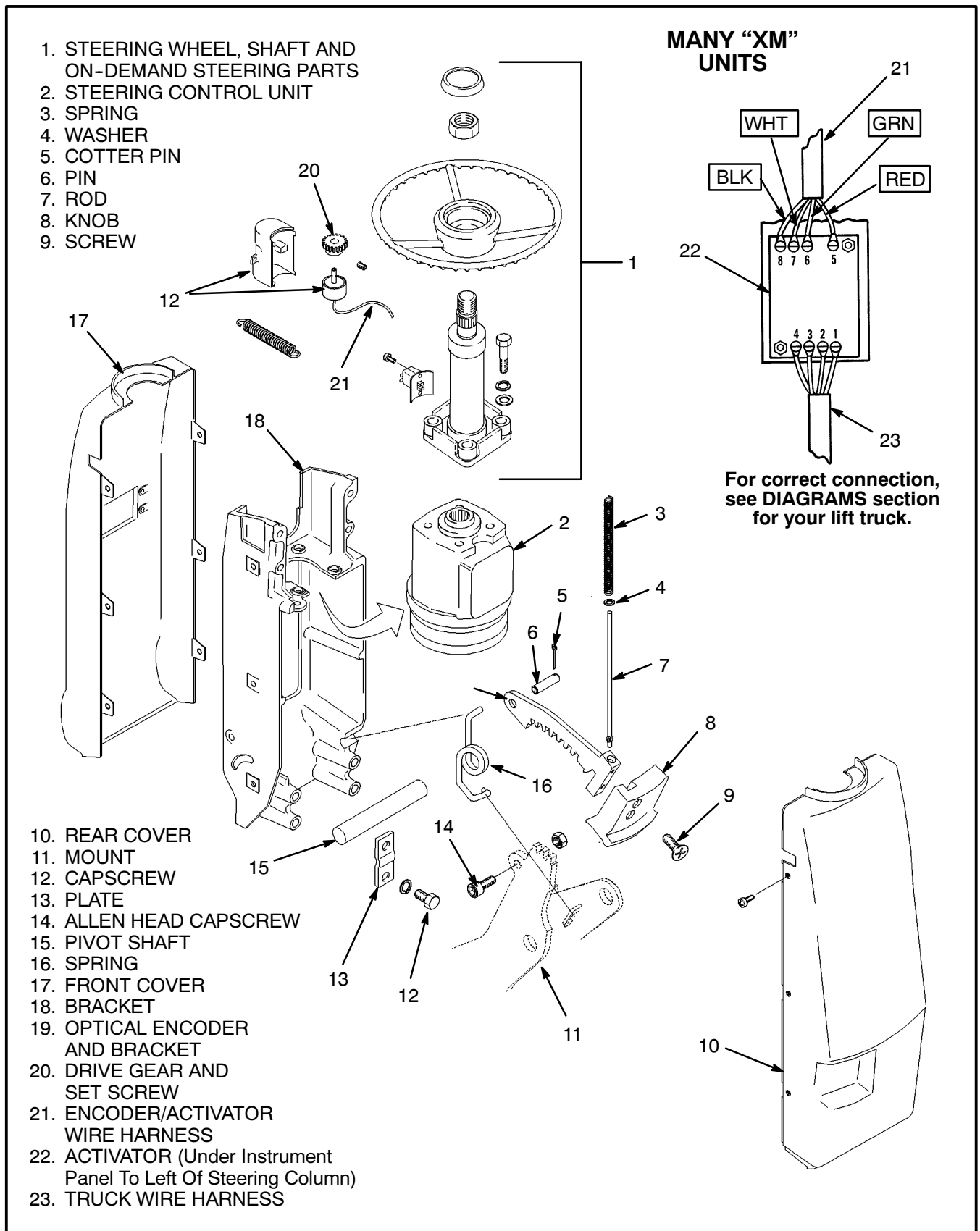

FIGURE 4. STEERING WHEEL AND STEERING COLUMN ASSEMBLY (3 of 3)

9. Remove the steering shaft as follows:

- a. Move the plastic tube and washer toward the steering control unit and compress the spring for the horn switch. Then remove the pin that goes through the steering shaft and engages the plastic tube.
- b. Remove the external snap ring that holds the bearing in the steering column. On units that have On-Demand steering, loosen the set screw in the gear on the shaft. The return spring, washer, and tube are removed at the same time as the steering shaft and bearing are removed. Use a small pry-bar at the bottom of the steering shaft near the steering control unit to remove the steering shaft and bearing (also, return spring, washer, and tube) from the steering column.

10. Remove the two capscrews that hold the steering control unit and the bracket to the steering column. Remove the four capscrews or nuts that fasten the steering control unit to the bracket.

NOTE: See the correct repair procedures to make repairs to the steering control unit. See the section, **THE STEERING CONTROL UNIT** for your unit.

Installation Of The Assembly Components

NOTE: This procedure is for the installation of all components of the steering column assembly. Usually it is not necessary to install all of the components. Do only those steps of the procedure necessary to install the component you need to install.

1. Install the steering column on the cowl mounts. Lubricate the pivots with multi-purpose grease and install the capscrews into the housing.
2. Fasten the two halves of the mount bracket to the steering control unit. Make sure to install bracket for activator if the activator is in the steering column. Install the steering control unit assembly into the steering column. Make sure to install the horn switch and the switch bracket as well as the two wire clamps on the same mount capscrews.
3. If removed, install the wires on the key switch as identified during removal. Install the key switch.

4. If removed, install the wires on the direction switch as identified during removal. Install the direction switch in the housing and install the nut, boot and handle.

5. Install the bearing on the steering shaft. The seal of the bearing must be toward the steering wheel. Install the snap ring in the groove on the steering shaft.

6. Put the steering shaft through the opening for the bearing in the steering housing. Install the gear for On-Demand steering onto the steering shaft. Install the pin that holds the plastic tube and flange for the horn switch. Install the plastic tube, the plastic flange and the spring onto the steering shaft. Push the steering shaft into the splines or align the tang of the steering control unit. Install the snap ring that holds the bearing in the steering housing.

7. If removed, install the optical encoder and bracket assembly on the column housing. Make sure the pinion gear of the optical encoder and the drive gear on the steering shaft are correctly aligned. Tighten the setscrew for the drive gear. Install the wires on the activator as identified during removal. The correct connections are also shown in FIGURE 4. Install the activator on the bracket fastened to the steering control unit

8. Install the steering wheel. Install the nut onto the steering shaft. Install the push rod and adjuster spool into the steering shaft. Install the base plate (not part of Petri steering wheel), the lock ring and the horn cover.

WARNING

The hydraulic hoses MUST be connected to the correct ports and fittings or the steering system will not operate as expected. This operation that is not expected can cause damage or personal injury. Connect the hoses as identified during removal.

9. Connect the hydraulic hoses to the steering control unit, the cowl, the control valve or the steering pump as removed during removal. Make sure each hydraulic hose is connected to the correct ports or fittings as identified during removal.

10. Connect the wire connectors at the bottom of the steering column. Install the access cover on the steering column.

POWER STEERING MOTOR AND PUMP

DESCRIPTION (See FIGURE 5.)

NOTE: See also the section HYDRAULIC SYSTEM for your lift truck model for additional information for the power steering pump of the “E” series lift trucks.

The power steering motor and pump assembly is under the floor plate on all units except the J2.00-3.20XM (J40-65XM), E1.50-2.00XMS (E25-40XMS) and E3.50-5.50XL (E70-120XL, E70-120XL₃) units. The E1.50-2.00XMS (E25-40XMS) and the E3.50-5.50XL (E70-120XL, E70-120XL₃) units have the motor and pump assembly under the battery compartment. The J2.00-3.20XM (J40-65XM) units have the motor and pump assembly mounted behind the battery compartment. The power steering motor and pump operate as described in DESCRIPTION in front part of this manual.

REMOVAL AND DISASSEMBLY, E1.25-3.00XL (E25-60XL), J2.00-3.00XL (J40-60XL), E2.00-3.20XM (E45-65XM), N30XMH (See FIGURE 5., FIGURE 8. and FIGURE 9.)

NOTE: On some units, the power steering motor must be removed from the mounts on the frame to replace the brushes. Other motors require removal of the end bell to replace the brushes.

1. Disconnect the battery and attach a tag on the truck battery connector stating “DO NOT CONNECT BATTERY”.
2. Remove the floor plate.
3. Install identification tags on the power cables and disconnect them from the power steering motor.
4. Attach identification tags on the electrical wires and disconnect them from the pressure switch.
5. Put a drain pan under the pump. Install identification tags on the hydraulic hoses and disconnect them from the power steering pump. Quickly put plugs in the ends of the hoses and the pump ports to keep oil from draining and dirt from entering the system.

6. Remove the two clamp capscrews and nuts, the washers and the two mounts. Remove the motor, pump, and bracket as an assembly.

7. Check the motor brushes. See the sections **PERIODIC MAINTENANCE** for your truck model and **DC MOTOR MAINTENANCE, 620 SRM 294** for additional information for inspection of the brushes and commutator.

8. If the motor must be disassembled for cleaning or repairs, remove the pump so that a new oil seal can be installed. Before disassembling the motor, make match marks for alignment on the end plates and the motor housing. These marks are necessary to assemble the motor correctly. To disassemble the motor, see FIGURE 8. Also see FIGURE 9.

9. Make a note of the position of the inlet and outlet ports of the pump for correct alignment to the motor during assembly. Remove the capscrews that fasten the pump to the motor and carefully remove the pump. Remove the O-ring at the pump shaft.

REMOVAL AND DISASSEMBLY, E3.50-5.50XL (E70-120XL, E70-120XL₃) (See FIGURE 5. and FIGURE 9.)

1. Remove the battery and put the lift truck on blocks as described in the **OPERATING MANUAL** or the section **PERIODIC MAINTENANCE**.
2. Install identification tags on the power cables and disconnect them from the pump motor.
3. Attach identification tags on the electrical wires and disconnect them from the pressure switch.
4. Put a drain pan under the pump. Install identification tags on the hydraulic hoses and disconnect them from the power steering pump. Quickly put plugs in the ends of the hoses and the pump ports to keep oil from draining and dirt from entering the system.
5. The capscrews for the motor mount are accessible from under the truck. Remove the mount capscrews and the motor and pump as one assembly.
6. Check the motor brushes. See the sections, **PERIODIC MAINTENANCE** for your truck model and **DC MOTOR MAINTENANCE, 620 SRM 294** for addi-

tional information for inspection of the brushes and commutator.

7. If the motor must be disassembled for cleaning or repairs, remove the pump so that a new oil seal can be installed. Before disassembling the motor, make match marks for alignment on the end plates and the motor housing. These marks are necessary to assemble the motor correctly. To disassemble the motor, see FIGURE 9.

8. Make a note of the position of the inlet and outlet ports of the pump for correct alignment to the motor during assembly. Remove the capscrews that fasten the pump to the motor and carefully remove the pump. Remove the O-ring at the pump shaft. See REPAIRS, POWER STEERING PUMP to disassemble the pump.

**REMOVAL AND DISASSEMBLY,
J2.00-3.20XM (J40-65XM)
(See FIGURE 6. and FIGURE 8.)**

⚠ WARNING

Put the lift truck on blocks on a solid, even and level surface. Make sure the blocks or stands have enough capacity to hold the lift truck. Use additional blocks

next to the tires as necessary to prevent movement of the lift truck. Make sure the lifting devices used during repairs can lift the weight of the parts and assemblies.

Completely deflate the tires before removing them from the lift truck. Air pressure in the tires can cause the tire and rim parts to explode causing serious injury or death.

NOTE: The J2.00-3.20XM (J45-65XM) units must be on blocks and a wheel removed to remove the steering motor and pump. Put the lift truck on blocks as described in the **OPERATING MANUAL** or the section **PERIODIC MAINTENANCE**.

1. Turn the key to the **OFF** position and remove the key. Remove the left steer wheel using the following procedure: put the steer axle on blocks so that the tires are raised from the floor. Remove the grease cap. Remove the cotter pin and the castle nut. Remove the outer bearing cone. Slide the wheel from the spindle. Remove the inner bearing cone and the seal from the spindle.

2. Remove the fender shield that is located above the steer wheel on the left side.

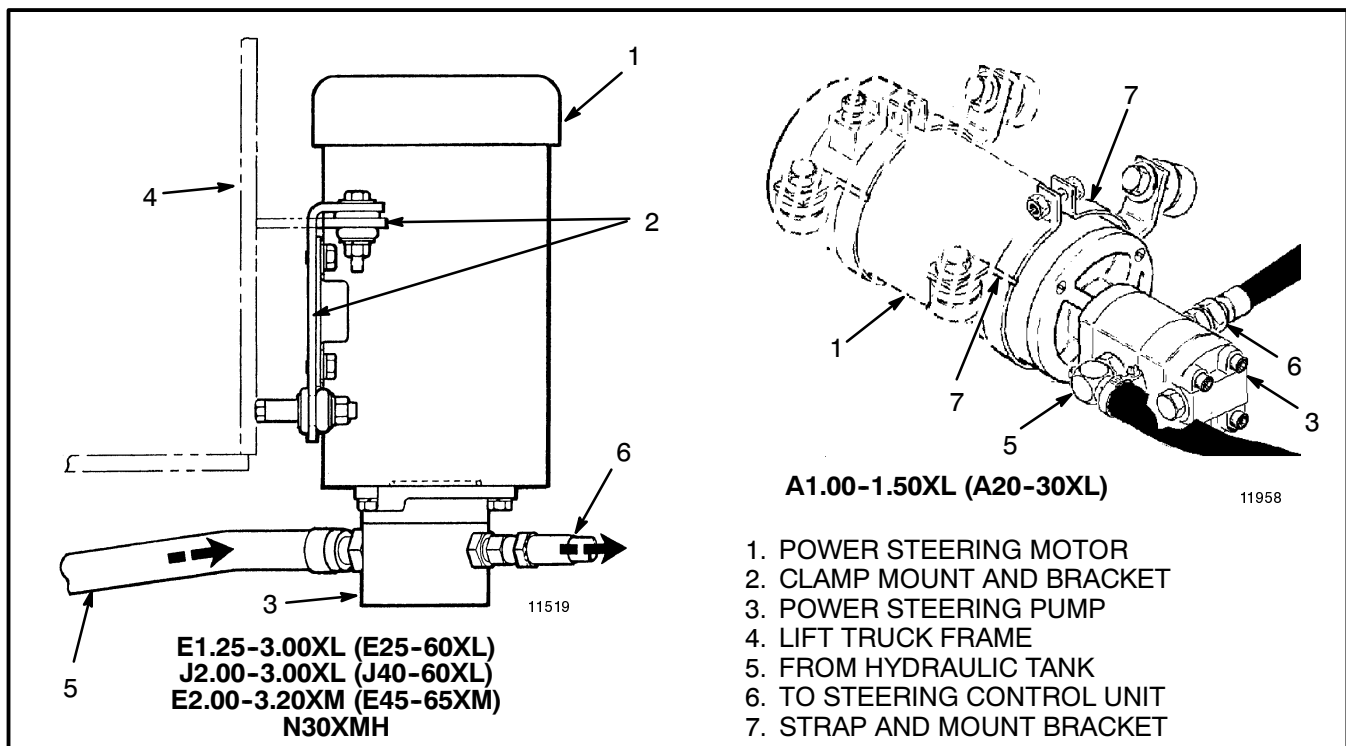

FIGURE 5. POWER STEERING MOTOR AND PUMP

⚠ WARNING

Never put tools or other metal objects on the battery. Metal on the battery can cause a short circuit and possible damage or injury.

3. Open the hood and install a cardboard or plywood cover on the top of the battery to prevent accidental short circuits.
4. Remove the cover panel from the left side of the battery.
5. Remove the cover from the top of the counterweight.
6. Remove the suction hose at the pump. Quickly put plugs in the end of the hose and the pump port to keep oil from draining and dirt from entering the system.

7. Disconnect the pressure hose from the steering pump. Install a plug at the fitting for the hose and the pump port.

8. If installed, disconnect the electrical plug at the pressure switch on the bottom of the pump.

9. Attach identification tags on the electrical cables. Disconnect the cables from the pump.

10. Install a sling around the steering pump and motor assembly. Connect a crane to the sling and raise the crane so that it supports the assembly. The pump and motor assembly weighs approximately 18.5 kg (41 lb) or more.

11. Remove the capscrews that fasten the mounting bracket to the lift truck frame. See FIGURE 6.

12. Remove the pump and motor as an assembly. Remove the pump from the motor.

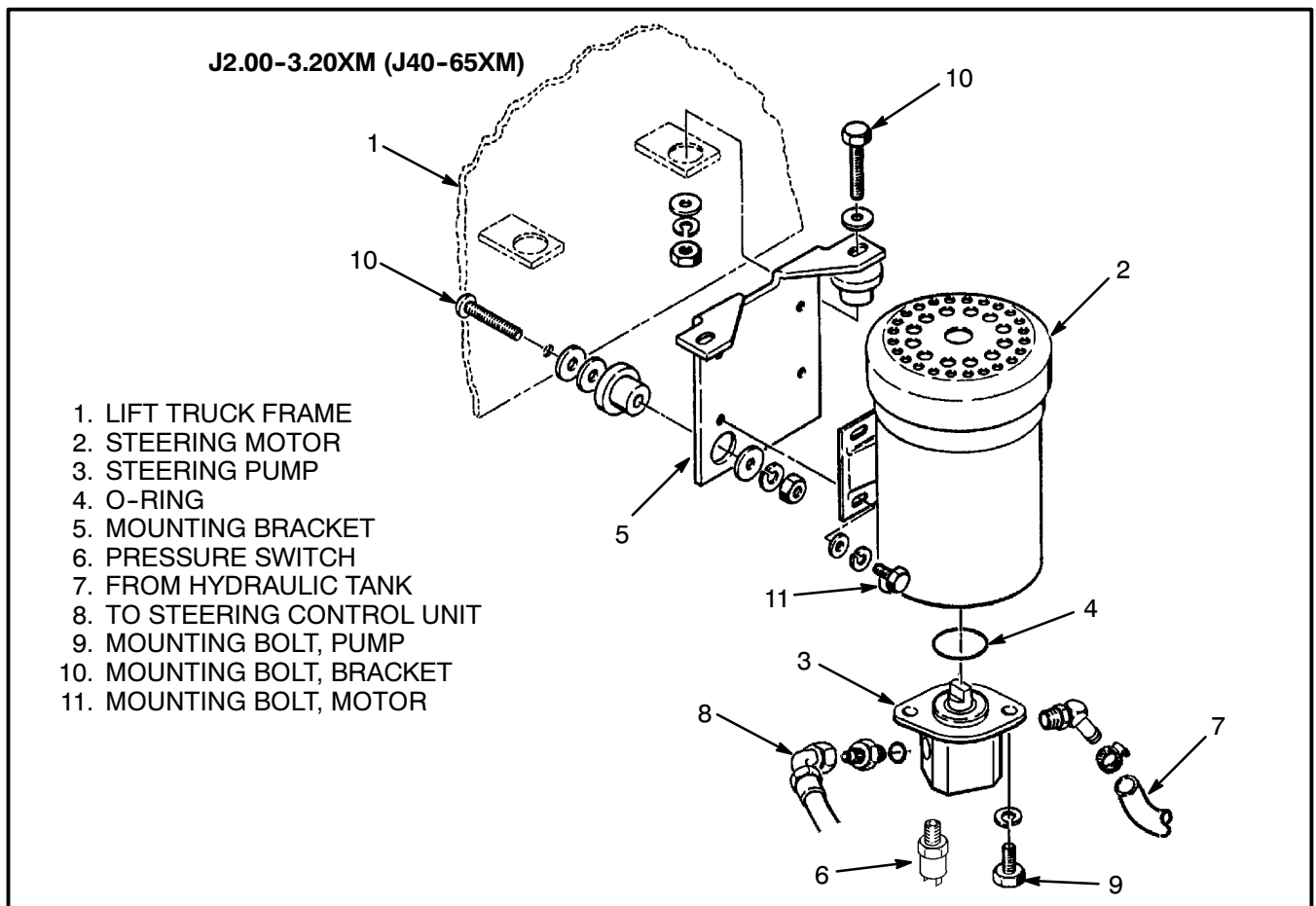

FIGURE 6. POWER STEERING MOTOR AND PUMP

13. Check the motor brushes. See the sections, **PERIODIC MAINTENANCE**, (for your truck model) and **DC MOTOR MAINTENANCE, 620 SRM 294** for additional information for inspection of the brushes and commutator.

14. If the motor must be disassembled for cleaning or repairs, remove the pump so that a new oil seal can be installed. Before disassembling the motor, make match marks for alignment on the end plates and the motor housing. These marks are necessary to assemble the motor correctly. To disassemble the motor, see FIGURE 8.

15. Make a note of the position of the inlet and outlet ports of the pump for correct alignment to the motor during assembly. Remove the capscrews that fasten the pump to the motor and carefully remove the pump. Remove the O-ring at the pump shaft. See **REPAIRS, POWER STEERING PUMP** to disassemble the pump.

REMOVAL AND DISASSEMBLY, A1.00-1.50XL (A20-30XL)
(See FIGURE 5. and FIGURE 9.)

1. Remove the floor plate.

2. Attach identification tags on the power cables and disconnect them from the power steering motor.

3. Put a drain pan under the steering pump. Remove the hose at the pump that comes from the hydraulic tank. Quickly put plugs in the end of the hose and the pump port to keep oil from draining and dirt from entering the system.

4. Loosen the straps that hold the power steering motor to the mounts on the frame and remove the power steering motor and pump.

CAUTION

The power steering motor and pump assembly has a weight of approximately 11 to 22kg (25 to 50lb). The power steering motor has ceramic permanent magnets. If the motor falls, the magnets can be damaged.

5. Remove the pump from the motor.

6. Check the brushes. See the sections, **PERIODIC MAINTENANCE**, (for your truck model) and **DC MOTOR MAINTENANCE, 620 SRM 294** for additional information for inspection of the brushes and commutator.

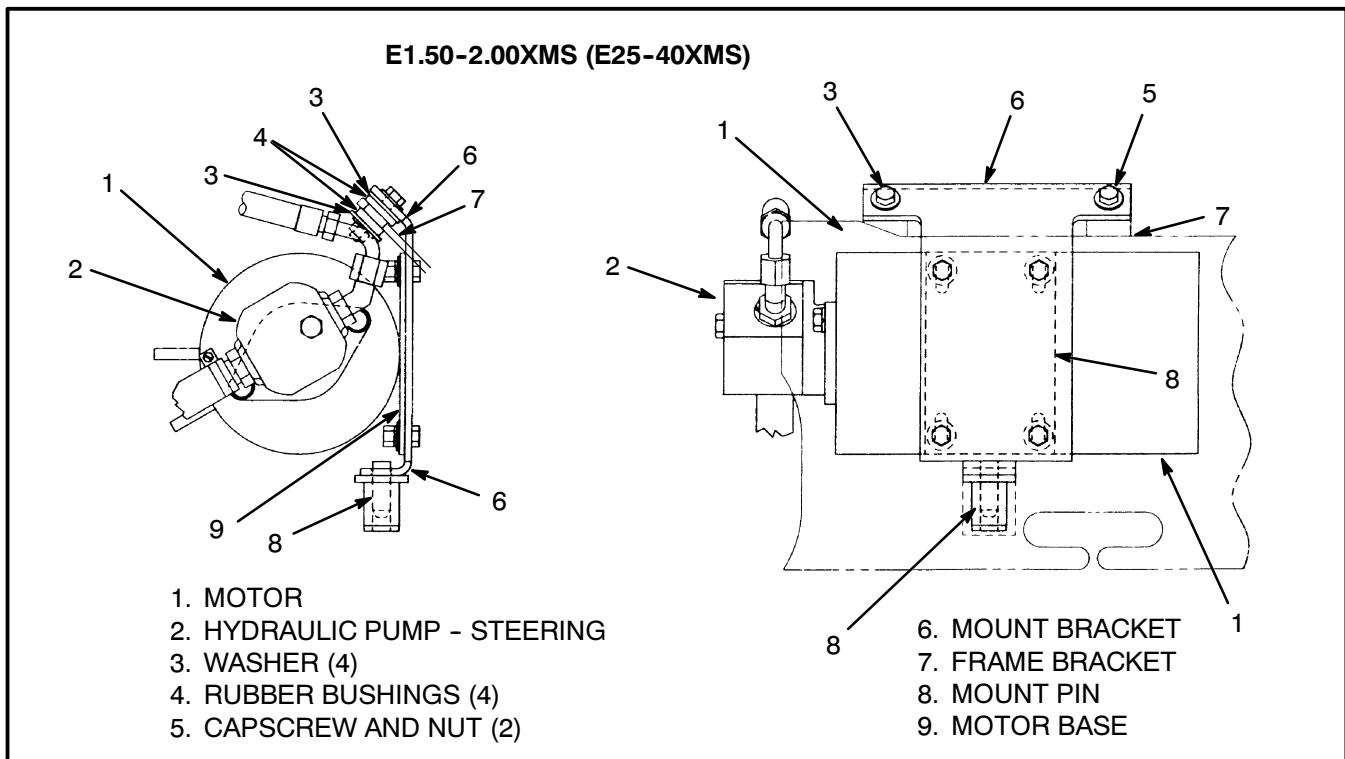

FIGURE 7. POWER STEERING MOTOR AND PUMP

7. If the motor must be disassembled for cleaning or repairs, remove the pump so that a new oil seal can be installed. Before disassembling the motor, make match marks for alignment on the end plates and the motor housing. These marks are necessary to assemble the motor correctly. To disassemble the motor, see FIGURE 9.

8. Make a note of the position of the inlet and outlet ports of the pump for correct alignment to the motor during assembly. Remove the capscrews that fasten the pump to the motor and carefully remove the pump. Remove the O-ring at the pump shaft. See REPAIRS, POWER STEERING PUMP to disassemble the pump.

REMOVAL AND DISASSEMBLY, E1.50-2.00XMS (E25-40XMS) (See FIGURE 7. and FIGURE 8.)

1. Disconnect the battery connector. Remove the floor plate. Remove the battery as described in the **OPERATING MANUAL** or the section **PERIODIC MAINTENANCE**. Remove the breather for the hydraulic tank and install a plug in the breather hose. Make sure the dipstick/fill cap is tight. This will help prevent oil flow when the hydraulic line is disconnected.

2. Put a drain pan under the steering pump and remove the hose from the hydraulic tank. Oil will flow from the hose, so quickly install a plug in the hose fitting.

3. Disconnect the other hose for the steering pump. Install a plug at the fitting for the hose. If installed, disconnect the electrical plug at the pressure switch on the bottom of the motor.

4. Install tags for correct connection during installation and disconnect the electrical cables at the pump motor terminals.

5. Install a sling around the steering pump and motor assembly. Connect a crane to the sling and raise the crane so that it is a support for the assembly. Make sure the crane and sling have a capacity of 18.5 kg (41 lb) or more.

6. Make a note of the positions of the rubber bushings at the mount brackets and remove the capscrews that fasten the brackets.

7. Carefully lift the steering pump and motor assembly up out of the frame. Do not damage the pressure switch on the bottom of the pump.

NOTE: Do not remove the mount brackets from the motor base unless the motor will be replaced. These brackets must be correctly aligned on the motor base.

8. Make a note of the position of the inlet and outlet ports of the pump for correct alignment to the motor during assembly. Remove the two capscrews that fasten the pump to the motor and carefully remove the pump. Remove the O-ring at the pump shaft.

9. If necessary, disassemble the motor as shown in FIGURE 8. See REPAIRS, POWER STEERING PUMP to disassemble the pump.

ASSEMBLY AND INSTALLATION [All models with a vertical mount except the J2.00-3.20XM (J40-65XM)]

1. When the end plate with the brush holder is installed, push the brushes into their holders so that the spring pushes against the side of the brush. This arrangement will permit easier installation of the brushes on the commutator.

2. Install the end plates to the motor housing and align the marks for assembly.

3. Install the brushes into their holders. Make sure that the brushes move freely in their holders. Make sure the spring pushes evenly on the brush.

4. Install a new seal ring on the motor shaft. Install a new O-ring between the motor and the pump. The shaft seal ring and the O-ring must be in good condition or the oil which lubricates the coupling can leak.

5. Install the pump on the motor. Make sure the pump shaft correctly engages the motor shaft.

6. Put the power steering motor and pump into position on the frame mount before the strap is tightened. Tighten the strap and install the power cables as marked during removal.

NOTE: Tighten the connections for power cables at M8 or $\frac{5}{16}$ inch terminals, on General Electric Motors, to 18 to 22 Nm (13 to 16 lbf ft).

7. Connect the hydraulic hoses to the hydraulic pump.

**ASSEMBLY AND INSTALLATION,
J2.00-3.20XM (J40-65XM)**

pushes against the side of the brush. This arrangement will permit easier installation of the brushes on the commutator.

1. When the end plate with the brush holder is installed, push the brushes into their holders so that the spring

2. Install the end plates to the motor housing and align the marks for assembly.

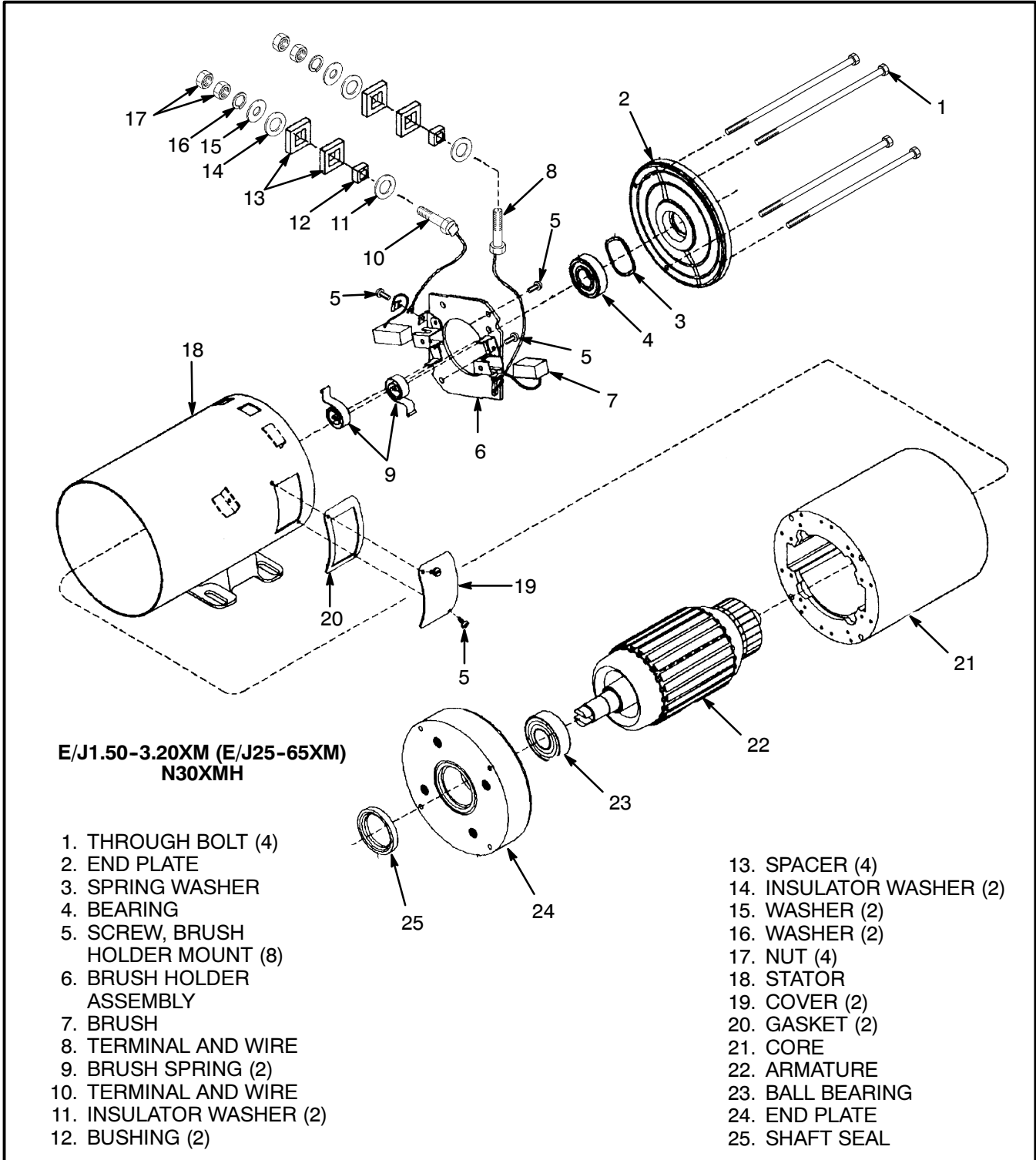
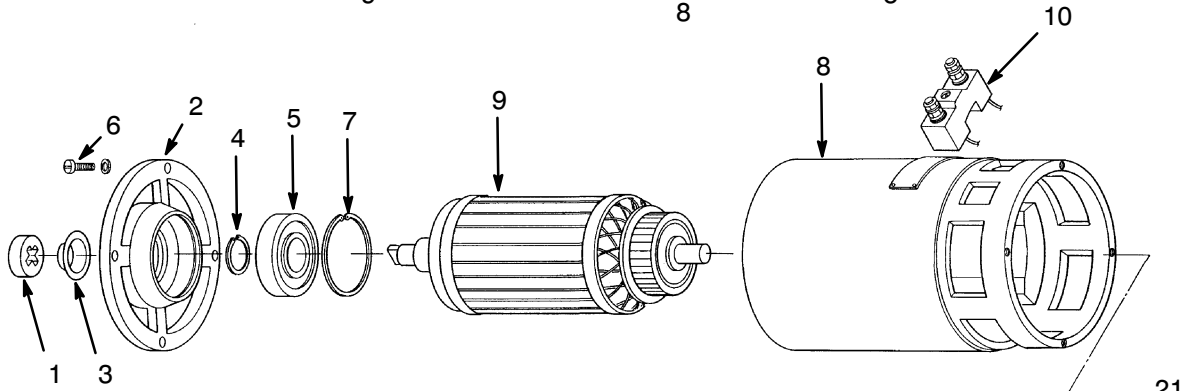
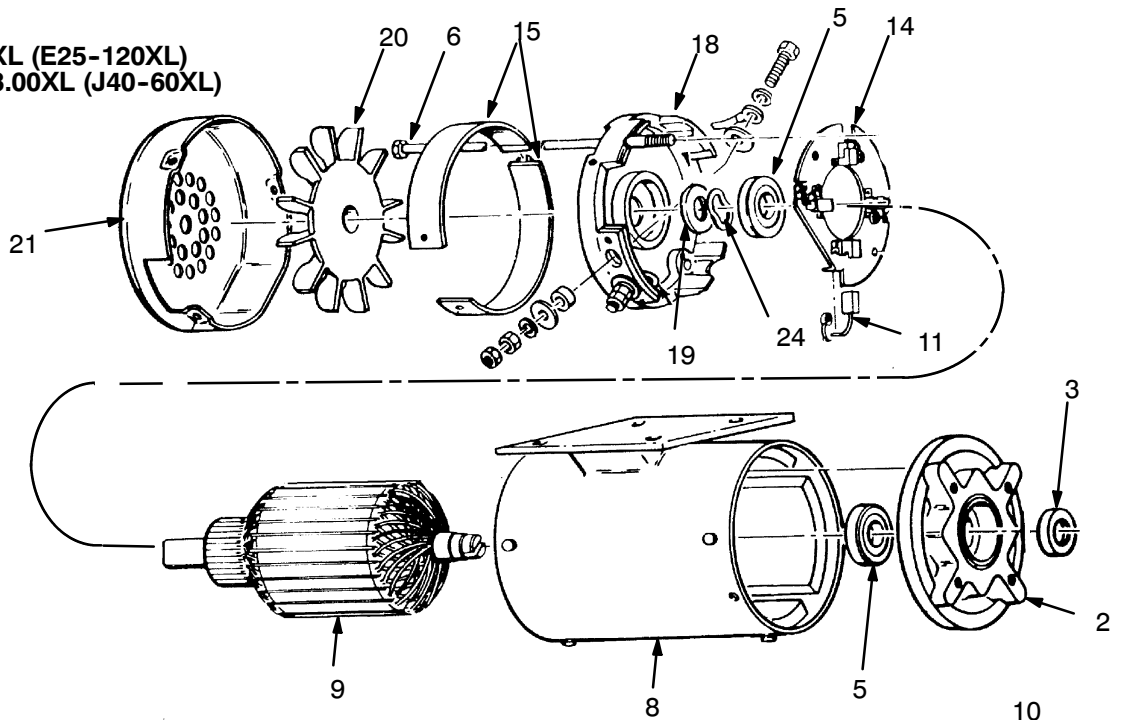

FIGURE 8. POWER STEERING PUMP MOTOR

E1.25-5.50XL (E25-120XL)
and J2.00-3.00XL (J40-60XL)



A1.00-1.50XL
(A20-30XL)

- | | | |
|---------------------|-----------------------|----------------------------|
| 1. COUPLING | 9. ARMATURE | 17. DISK |
| 2. END PLATE, DRIVE | 10. POWER TERMINAL | 18. END PLATE, COMMUTATOR |
| 3. SEAL | 11. BRUSH | 19. SHIM |
| 4. RETAINING RING | 12. BRUSH HOLDER | 20. FAN |
| 5. BEARING | 13. PLATE NUT | 21. FAN COVER |
| 6. SCREW, HOUSING | 14. BRUSH PLATE | 22. BRUSH PLATE SCREWS (2) |
| 7. RETAINING RING | 15. COVER, COMMUTATOR | 23. SCREW, FAN COVER |
| 8. MOTOR HOUSING | 16. BEARING | 24. SPRING WASHER |

11997

FIGURE 9. POWER STEERING PUMP MOTOR

3. Install the brushes into their holders. Make sure that the brushes move freely in their holders. Make sure the spring pushes evenly on the brush.

4. Install a new seal ring on the motor shaft. Install a new O-ring between the motor and the pump.

5. Install the pump on the motor. Make sure the pump shaft correctly engages the motor shaft.

6. Attach the motor to the mounting bracket. Make sure the motor is correctly aligned on the mounting bracket.

7. Attach a sling around the motor. Position the sling so that passes through the area where the steering motor mounts. Attach a crane to the sling, and carefully lift the motor into position. Make sure the switch on the bottom of the pump is not damaged.

8. Raise the motor into position. Install the mounting bolts that attach the mounting bracket to the lift truck frame.

NOTE: Tighten the connections for power cables at M8 or $\frac{5}{16}$ inch terminals, on General Electric Motors, to 18 to 22 Nm (159 to 195 lbf in).

9. Attach the electrical cables to the motor as marked during removal.

10. If installed, attach the electrical plug to the pressure switch on the bottom of the pump.

11. Attach the pressure hose to the pump.

12. Attach the suction hose to the pump.

13. Install the cover on the counterweight.

14. Install the cover panel on the left side of the truck.

15. Install the fender shield.

16. Carefully slide the wheel onto the spindle. Install the outer bearing cone.

17. Install the castle nut. Tighten the castle nut to 200 Nm (150 lbf ft) while the wheel is rotated. Loosen the nut to less than 27 Nm (20 lbf ft). Tighten the nut to 34 Nm (25 lbf ft). If the cotter pin can not be installed with the nut tightened to 34 Nm (25 lbf ft), tighten the castle nut until the cotter pin can be installed. Install the cotter pin.

ASSEMBLY AND INSTALLATION, E1.50-2.00XMS (E25-40XMS)

1. Install a new O-ring at the shaft of the replacement pump. Install the replacement pump on the motor using the two capscrews. Make sure the pump is correctly aligned with the motor as noted during disassembly.

2. If removed, install the pressure switch in the pump end frame.

3. If the mount brackets were removed from the motor base, the brackets must be correctly aligned before installation of the assembly. Align the brackets as follows:

- a. Install the mount brackets on the motor base. See FIGURE 9. Leave the capscrews and nuts loose so that the brackets can move.
- b. Align the two brackets so that the center lines of the capscrew holes are 160 mm (6.3 in) apart as shown in FIGURE 9. Keep the brackets centered in the slots of the motor base as much as possible.
- c. Carefully tighten the capscrews at the motor base without changing the alignment.

4. Install a sling around the steering pump and motor assembly. Use a crane to lift and align the assembly on the mounts in the lift truck frame.

5. Install the mount capscrews, washers and rubber bushings as noted during disassembly. See FIGURE 9. Install the clip nut at the top left mount of the frame. Tighten the capscrews without compressing the rubber bushings.

6. Connect the hydraulic line to the outlet port of the pump. Install a drain pan under the pump and quickly install the hose from the hydraulic tank to the inlet port.

7. Install the electrical plug on the terminals of the pressure switch. Install the electrical cables on the motor terminals as noted during removal. Tighten the connections for power cables to the correct torque values as follows:

$\frac{5}{16}$ UNC threads - 13.5 to 17.5 Nm (120 to 155 lbf in)

$\frac{1}{4}$ UNC threads - 4.0 to 6.0 Nm (35 to 53 lbf in)

8. Remove the plug from the breather hose and install the breather. Install the battery as described in this section. Install the floor plate. Operate the steering system and check for leaks.

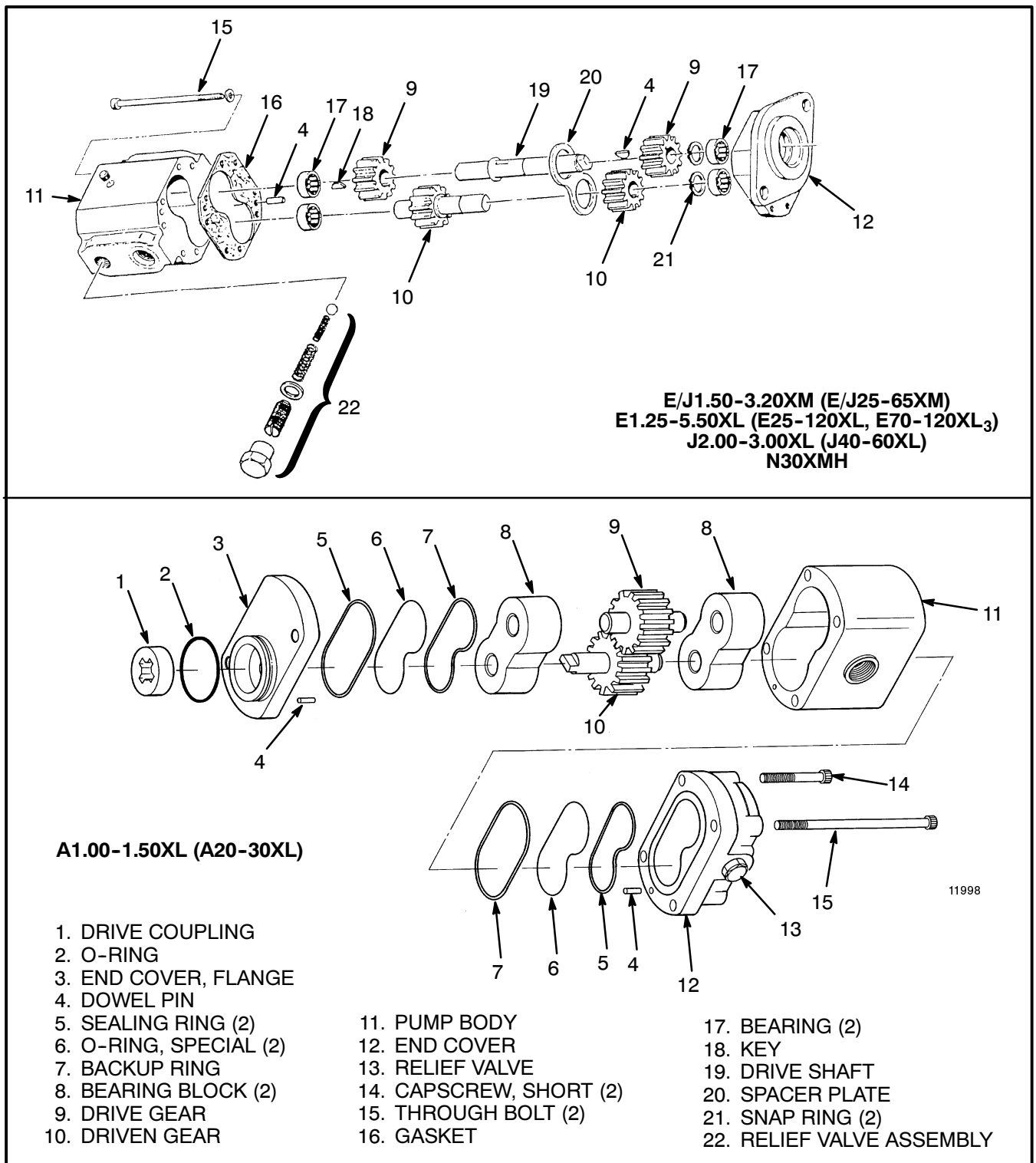

FIGURE 10. POWER STEERING PUMP

REPAIRS, POWER STEERING PUMP

Seals that are worn or damaged are the most common cause of pump repair. The pump bearings, gears, and shafts also wear. Most service persons do not repair a worn pump. The cost of repairs can be greater than the

cost of a new pump. The seals can be replaced in the hydraulic pump. Replace a hydraulic pump that is worn or damaged.

The power steering pump is a single section gear pump that is fastened to the power steering motor. The inlet

(suction port) of the pump is connected to the hydraulic tank with a hydraulic hose. Bushings at each side of each gear are the bearings for the gear shafts. The bushings also have passages for the oil flow to the pump outlet and for lubrication. Seals prevent leaks between sections of the pump housing. A coupling is connected between the motor shaft and the pump shaft. A relief valve in the outlet of the pump controls the pressure in the steering system.

When the pump is installed on the motor, use a new O-ring between the pump and the motor housings.

Seal Replacement

NOTE: If the pump is held in a vise for disassembly, do not cause distortion of the pump body. Use a vise with soft jaws or blocks of soft wood between the pump body and the jaws of the vise.

Make an identification of the location of the parts and seals during disassembly. Similar parts can cause errors during assembly. Identification of the parts can be difficult if the parts are mixed.

1. Remove the four capscrews that hold the pump together. Two of the capscrews are through bolts and fasten to the end plate of the motor.
2. Carefully remove the end covers and remove the seals and O-rings.
3. Carefully press the gear bearing and gear assemblies from the pump body.

HYDRAULIC STEERING MOTOR

NOTE: See the section, **STEERING AXLE, 1600 SRM 316** for the description and repair procedures for the steering cylinder of the J2.00-3.20XM (J40-65XM) and E/J1.25-3.00XL (E/J25-60XL) units. See the section, **STEERING AXLE, 1600 SRM 326** for the description and repair procedures for the steering cylinder of the E3.50-5.50XL (E70-120XL, E70-120XL₃) units. See the section, **STEERING AXLE, 1600 SRM 258** for the description and repair procedures for the steering cylinder of the E2.00-3.20XM (E45-65XM) and N30XMH units. See the section, **STEERING AXLE, 1600 SRM 619** for the description and repair procedures for the steering cylinder of the

4. Inspect the gear assemblies, the gear bearings and the pump body for wear or damage.

NOTE: Some pump bodies will show marks caused by gears as the gears rotate against the pump body. The small clearances between the parts cause the gears to leave the marks. These marks do not always indicate that the pump is worn or damaged. If the pump will not supply the volume and pressure shown in the specifications, then the pump must be repaired or replaced.

5. Clean the internal parts of the pump. Use hydraulic oil to lubricate the parts as they are installed into the pump. Install new seals in the bushings.
6. Install the gears and bushings in the pump body.
7. Install new O-rings, seal rings, and dowel pin into the end cover of the pump with the relief valve. See FIGURE 10. for the arrangement.
8. Install new O-rings, seal rings, and dowel pin into the other end cover with the flange. Install this end cover onto the pump.
9. Check that all of the parts are in the correct position, and install the four capscrews. Tighten the capscrews to 34 to 40 Nm (25 to 30 lbf ft).
10. Install a new O-ring on the flange to seal against the end plate of the motor. Install the pressure switch, except A1.00-1.50XL (A20-30XL) units.

E1.50-2.00XMS (E25-40XMS) units.

DESCRIPTION (See FIGURE 11.)

The hydraulic steering motor controls the position of the master drive unit (MDU) using a steering chain. The hydraulic motor rotates the MDU for steering the lift truck.

The part of the output shaft which is in the motor housing has two purposes: an output shaft and a distributor valve. The distributor valve rotates with the gear wheel. This distributor valve sends oil to the pressure chambers of the gear wheel set and takes oil away from the return chambers.

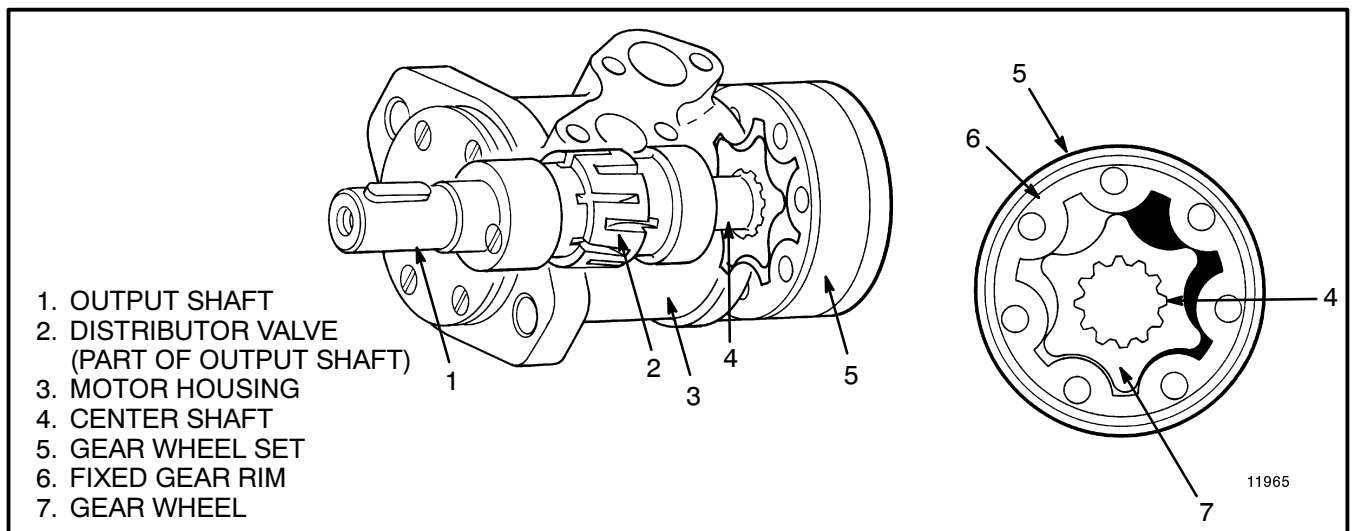

FIGURE 11. HYDRAULIC STEERING MOTOR, OPERATION

The hydraulic steering motor uses a gear wheel set inside of the motor to change hydraulic energy to mechanical energy. The gear wheel set has a fixed gear rim and a gear wheel. The center of the gear wheel moves around the center of the gear rim and at the same time the gear wheel rotates. The directions of these two motions are opposite. The center of the gear wheel moves around the center of the gear rim six times per revolution of the gear wheel.

REPAIRS, HYDRAULIC STEERING MOTOR

Removal

NOTE: Most service personnel remove the counterweight from the lift truck for this procedure. The hydraulic steering motor can be removed without removing the counterweight. Removal of the counterweight gives better access to the hydraulic steering motor, steering chain and the MDU. See the section, **THE FRAME** for the procedure to remove the counterweight.

1. Use the hex nut adjustment to loosen the steering chain on the MDU.
2. Identify the two hydraulic hoses to the hydraulic motor and disconnect them. Put caps over the ends of the hydraulic hose connectors and the motor ports.
3. Remove the two capscrews that fasten the hydraulic motor to the lift truck frame.

Disassembly (See FIGURE 12.)

1. Put the motor in a vise or other holding tool. If a vise is used, do not cause distortion of the motor housing. Use a vise with soft jaws.
2. Remove the capscrews from the end cover. Remove the end cover from the motor.
3. Lift the gear set and remove the O-rings. Remove the distributor plate.
4. Remove the center shaft. Remove the output shaft from the housing.
5. From the other end of the housing, remove the screws from the flange cover. Remove the flange cover. Remove the O-ring and bearing race from the flange cover.
6. Use a screwdriver to loosen and remove the shaft seal from the flange cover. Remove the dust seal from the flange cover.
7. Remove the needle bearings.

Cleaning And Inspection

⚠ WARNING

Cleaning solvents can be flammable and toxic, and can cause skin irritation. When using cleaning solvents, always follow the safety instructions of the solvent manufacturer.

Clean all parts with a mineral oil cleaning solvent.

Instant Download the Complete Manual

(Contents include: Brake system, Capacities and specifications, Frame, Hydraulic system, Industrial battery, Main control valve, Mast repair, fasteners, Schematics diagrams, Steering axle, Steering system, Wire harness repair And more)

Click Here BUY NOW

Thank you very much.