

# CAPACITIES AND SPECIFICATIONS

RS45-30CH, RS45-27IH, RS46-33CH, RS46-30IH,  
RS46-36CH, RS46-33IH Up to 1528, 1530,  
1531, and 1532 [A222]

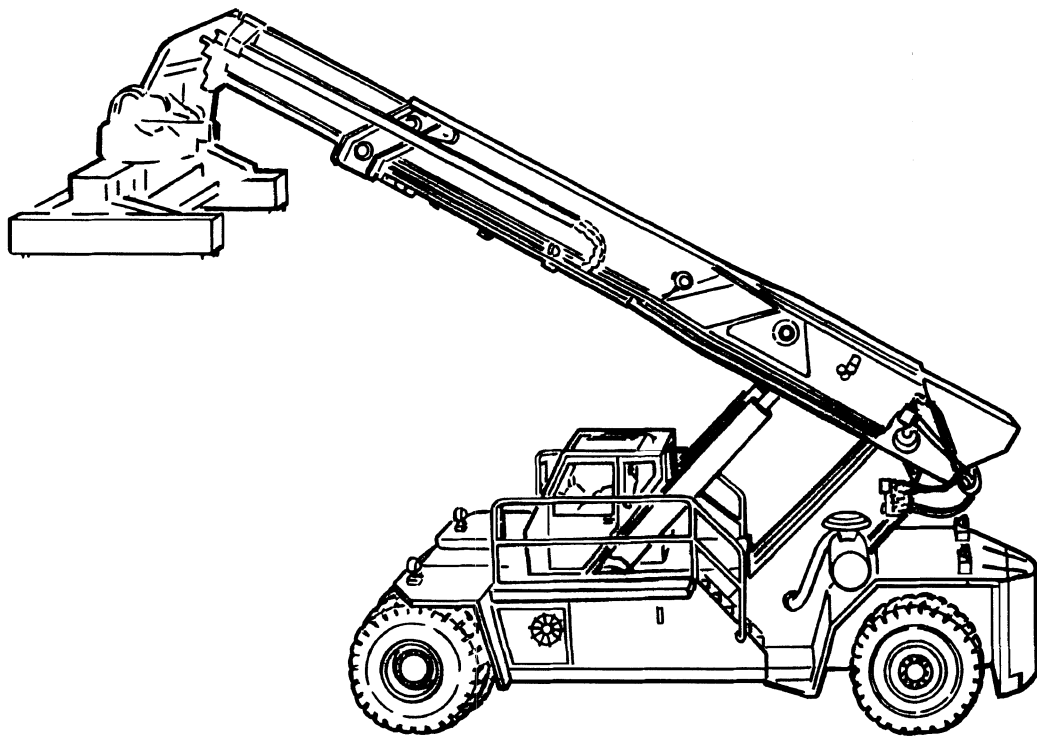

HM120358

# ***HYSTER***

## TABLE OF CONTENTS

Vehicle Weights .....	1
Capacities .....	1
Electrical System .....	1
Engine Specifications.....	1
Tire Sizes .....	2
Torque Specifications .....	2
Counterweight .....	2
Drive Axle .....	2
Drive Shaft.....	2
Steering Axle.....	2
Wheel Nuts.....	2
Lifting Capacities.....	3
Container Spreader .....	3
Intermodel Spreader.....	5

This section is for the following models:

RS45-30CH, RS45-27IH, RS46-33CH, RS46-30IH, RS46-36CH, RS46-33IH  
Up to 1528, 1530, 1531, and 1532 [A222]

(More Content includes: Brake system, Capacities, and specifications, Frame, Hydraulic, System, Industrial battery, Main control, Valve, Mast repair, Fasteners, Schematics diagrams, Steering axle, Steering system, Wire harness repair And more)

**[Click Here](#)**

**Get all the content  
after purchase**

**Thank you very  
much.**

## Vehicle Weights

Unit	Weight*
RS45-30CH	69,500 kg (153,250 lb)
RS45-25IH	74,500 kg (164,275 lb)
RS46-35CH	74,000 kg (163,170 lb)
RS46-30IH	79,000 kg (174,195 lb)
*Total vehicle weight, no load.	

## Capacities

Item	Quantity
Engine Oil	34 liter (36 qt)
Cooling System	35 liter (37 qt)
Hydraulic Tank	850 liter (224 gal)
Transmission	42 liter (44 qt)
Drive Axle and Differential	30 liter (32 qt)
Brake System Oil	95 liter (25 gal)
Fuel Tank	400 liter (106 gal)

## Electrical System

24 Volt, Negative Ground
<b>Alternator Output</b>
70 Amps

## Engine Specifications

Item	Specification
Type	Cummins LT 10
Number of Cylinders	6
Firing Order	1-5-3-6-2-4
Bore	125 mm (4.92 in.)
Stroke	136 mm (5.35 in.)
Displacement	10 liter (610 in. <sup>3</sup> )

## Tire Sizes

Model	Drive	Steer
RS45-30CH	18.00 × 25 - 40 ply	18.00 × 25 - 40 ply
RS45-25IH	18.00 × 25 - 40 ply	18.00 × 25 - 40 ply
RS46-35CH	18.00 × 33 - 36 ply	18.00 × 33 - 36 ply
RS46-30IH	18.00 × 33 - 36 ply	18.00 × 33 - 36 ply

## Torque Specifications

### COUNTERWEIGHT

#### Mounting Bolts

685 N•m (505 lbf ft)

### DRIVE AXLE

#### Mounting Bolts

1500 N•m (1100 lbf ft)

### DRIVE SHAFT

#### Universal Joint Nuts

156 N•m (115 lbf ft)

### STEERING AXLE

#### Steering Cylinder Mounting Bolts

1215 N•m (900 lbf ft)

### WHEEL NUTS

#### Drive Wheels

440 N•m (325 lbf ft)

#### Steer Wheels

140 N•m (100 lbf ft)

# Lifting Capacities

## CONTAINER SPREADER

See Figure 1 and Figure 2 for lifting capacities for RS46-35CH and RS45-30CH.

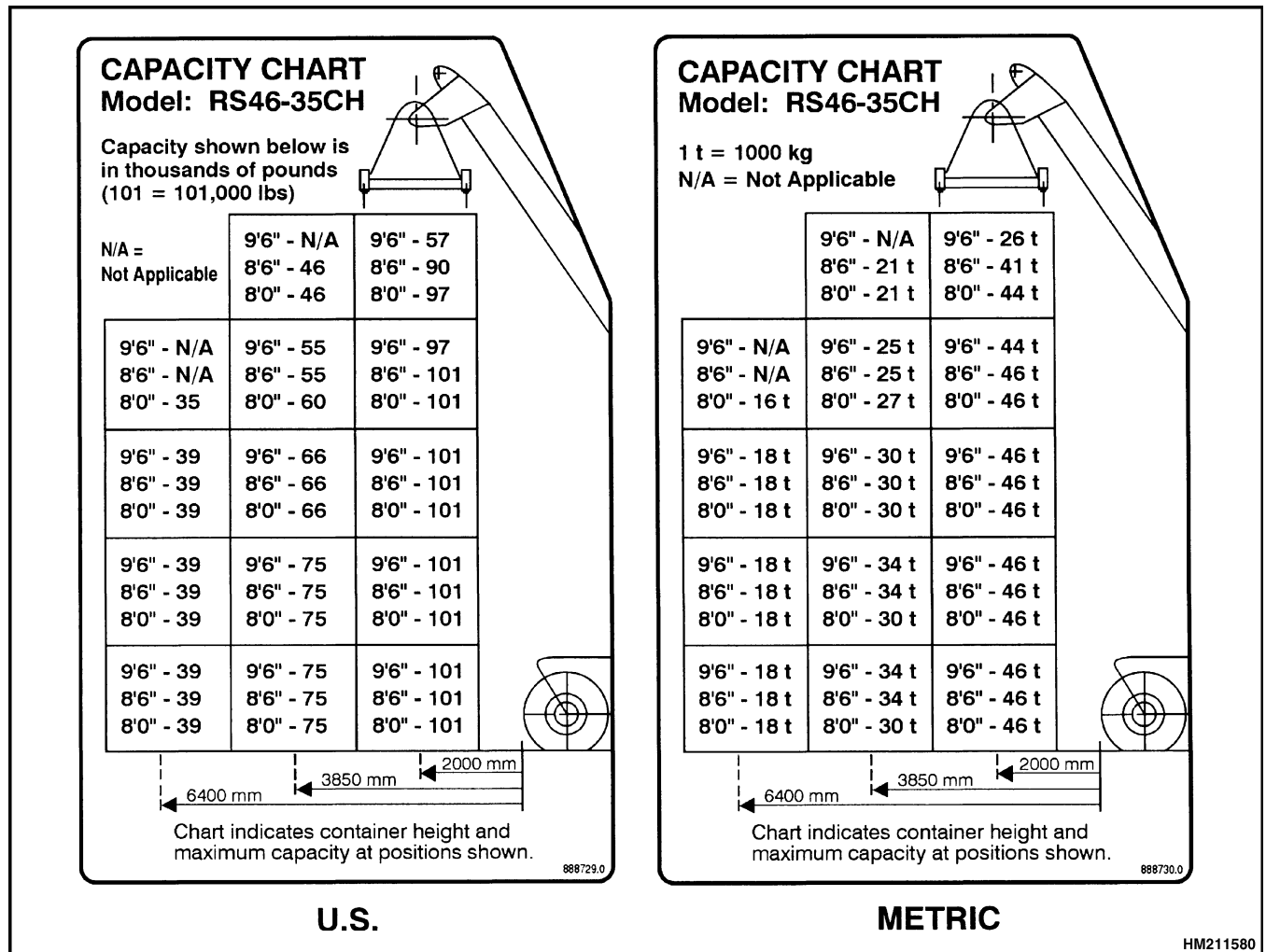
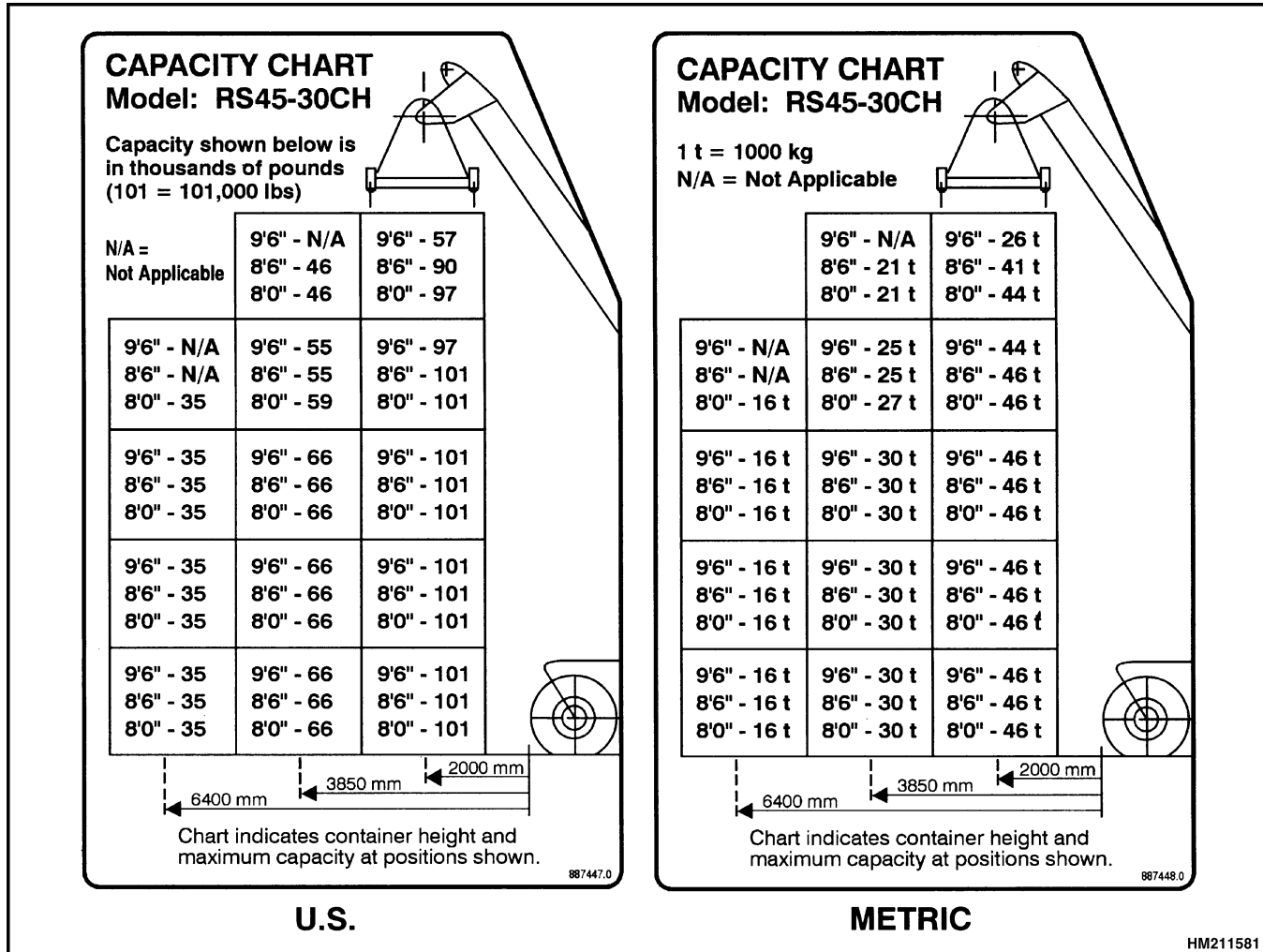

Figure 1. Lifting Capacities, Container Spreader



*Figure 2. Lifting Capacities, Container Spreader*

**INTERMODEL SPREADER**

See Figure 3 and Figure 4 for lifting capacities for RS45-25IH and RS46-30IH.

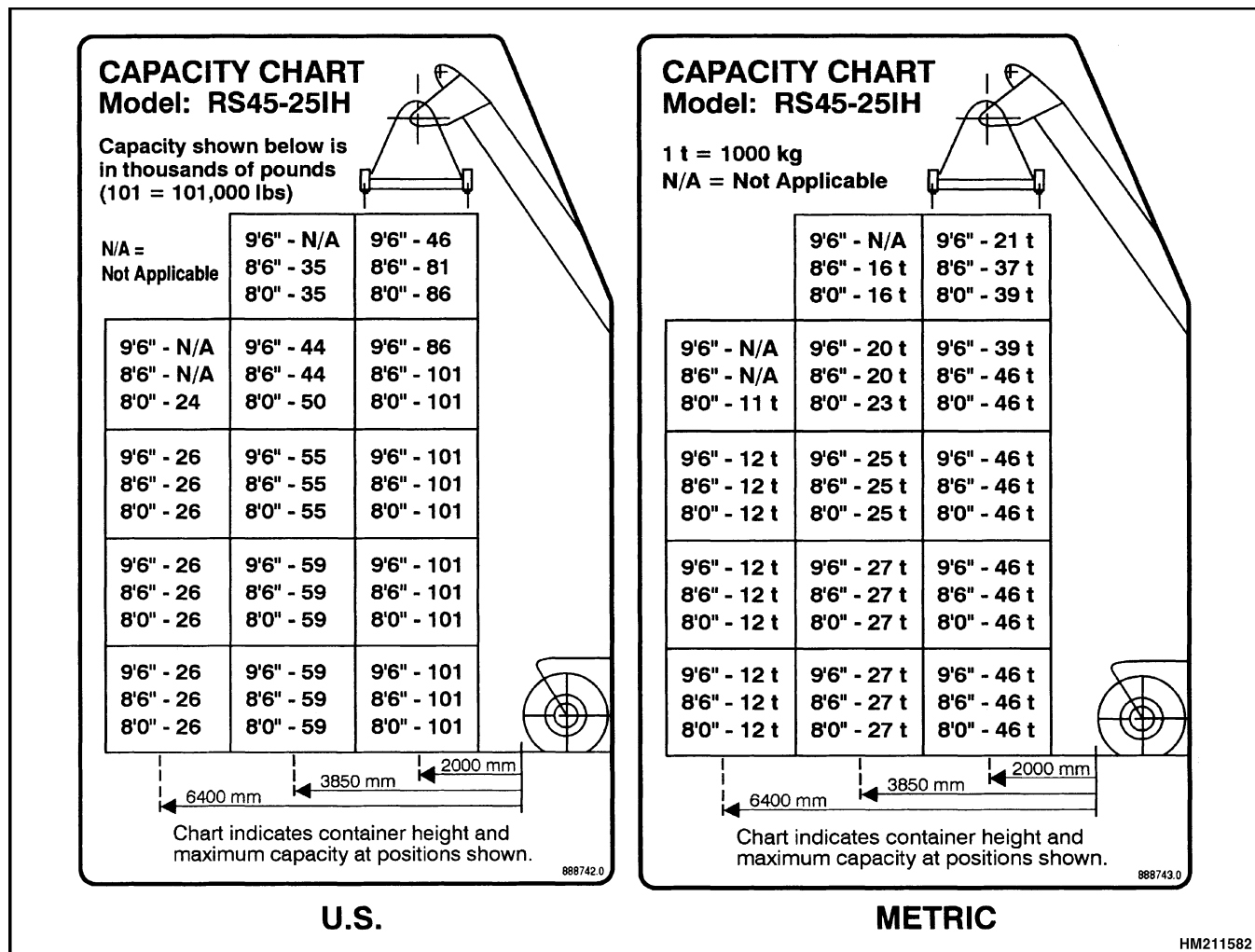
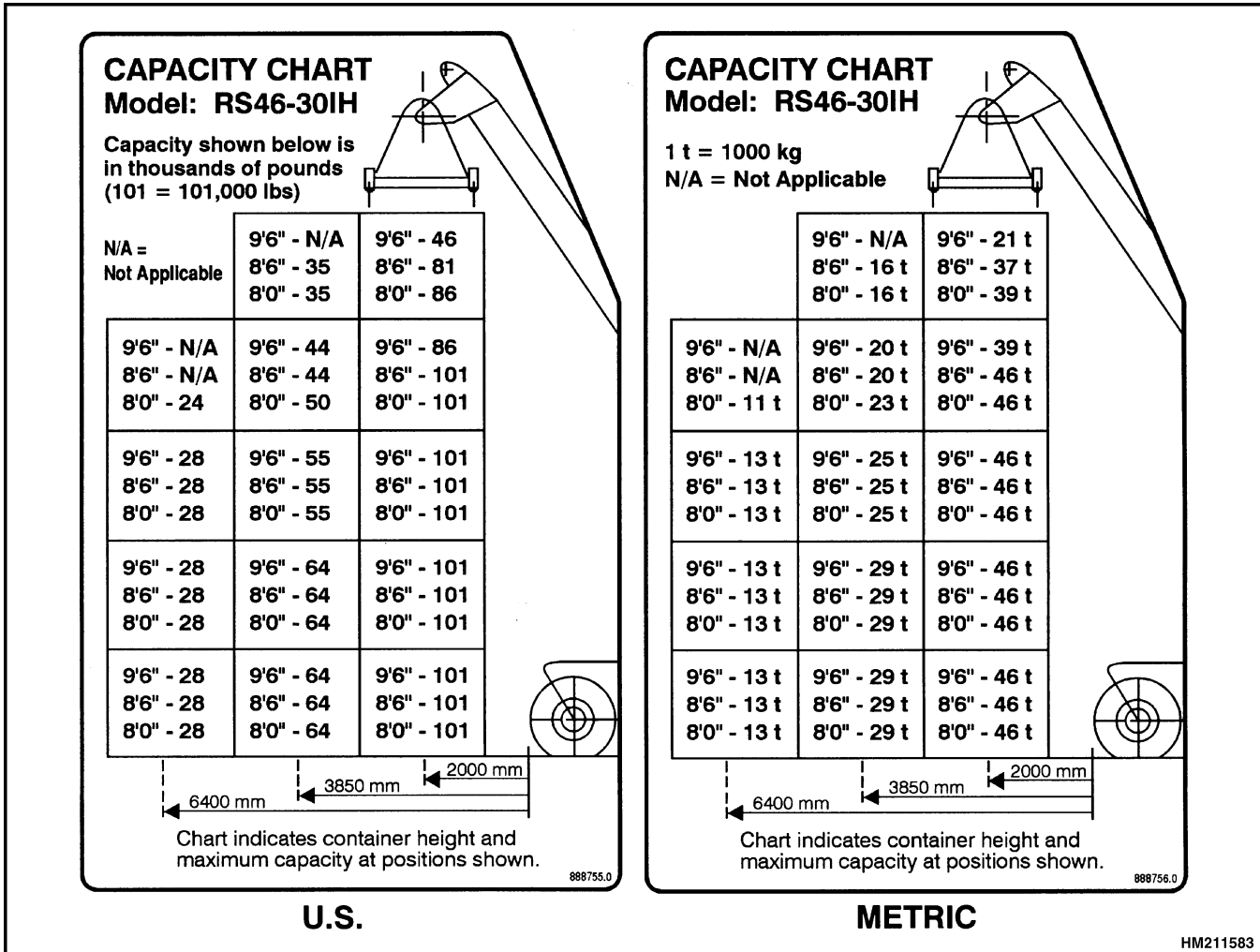

Figure 3. Lifting Capacities, Intermodal Spreader





*Figure 4. Lifting Capacities, Intermodal Spreader*

