

CAPACITIES AND SPECIFICATIONS

**H40.00-48.00XM-12
(H800-1050HD/HDS) [A917]**

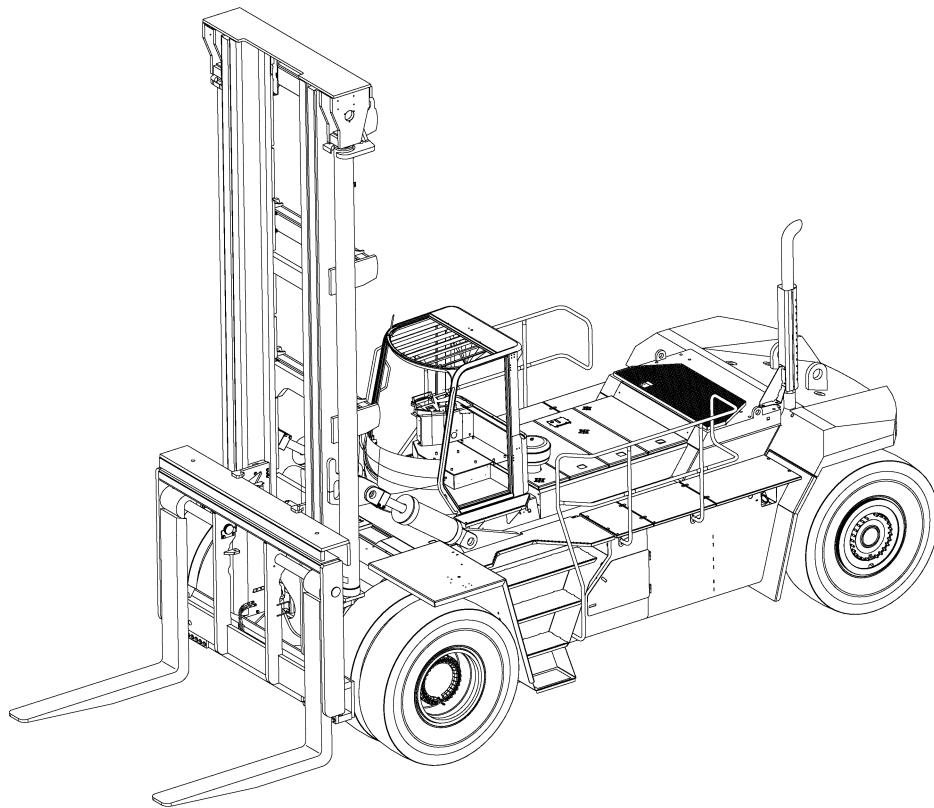

HYSTER

TABLE OF CONTENTS

Counterweight Weights	1
Carriage Weights	2
Vehicle Weight.....	2
Capacities	2
Electrical System	2
Engine Specifications (Cummins QSM11).....	3
Mast Weights.....	3
Lifting and Lowering Speeds.....	4
Tires	4
Forks	4
Hydraulic System Specifications.....	5
Torque Specifications	6
Control Valves.....	6
Electrical System	6
Counterweight (Fabricated).....	6
Counterweight (Secondary).....	6
Counterweight (Slab).....	6
Drive Axle	6
Wheel Bearing Adjusting Nut.....	6
Differential.....	6
Transmission.....	6
Torque Converter	6
Steering	6
Wheel Nuts.....	7
Carriages (All).....	7

This section is for the following models:

H40.00-48.00XM-12 (H800-1050HD/HDS) [A917]

Counterweight Weights

Table 1. Up to February 2007

Model	Main Counterweight	Secondary Counterweight
H40.00XM-12	10,700 to 11,021 kg (23,594 to 24,302 lb)	1,260 to 1,298 kg (2,779 to 2,862 lb)
H44.00 - 48.00XM-12, H1050HD	12,130 to 12,494 kg (26,747 to 27,550 lb)	

Table 2. February 2007 and Up

Model	Main Counterweight	Secondary Counterweight
H40.00XM-12	8,560 to 8,817 kg (18,875 to 19,442 lb)	3,920 to 4,038 kg (8644 to 8,904 lb)
H44.00XM-12	10,700 to 11,021 kg (23,594 to 24,302 lb)	
H48.00XM-12, H1050HD	12,130 to 12,494 kg (26,747 to 27,550 lb)	4,920 to 5,068 kg (10,849 to 11,175 lb)

Table 3. March 2007 and Up

Model	Main Counterweight	Secondary Counterweight
H800HD	8,560 to 8,817 kg (18,875 to 19,442 lb)	3,920 to 4,038 kg (8644 to 8,904 lb)
H900HD	10,700 to 11,021 kg (23,594 to 24,302 lb)	
H970HDS, H1050HDS	12,130 to 12,494 kg (26,747 to 27,550 lb)	4,920 to 5,068 kg (10,849 to 11,175 lb)

Table 4. Slab Counterweight (Up to February 2007)

Model	Slab Counterweight
H48.00XM-12	1400 to 1430 kg (3087 to 3153 lb)

(More Content includes: Brake system, Capacities, and specifications, Frame, Hydraulic, System, Industrial battery, Main control, Valve, Mast repair, Fasteners, Schematics diagrams, Steering axle, Steering system, Wire harness repair And more)

[Click Here](#)

**Get all the content
after purchase**

**Thank you very
much.**

Carriage Weights

Carriage	Weight
Fork Sideshift	5343 kg (11,779 lb)
Fork Positioner	3130 kg (6900 lb)

Vehicle Weight

Unit	Weight
H40.00XM-12	50,120 kg (110,515 lb)
H44.00XM-12	52,350 kg (115,432 lb)
H48.00XM-12	55,150 kg (121,606 lb)
H800HD	N/A
H900HD	N/A
H970HDS	N/A
H1050HD	55,150 kg (121,606 lb)
H1050HDS	N/A

NOTE: With 4.41 m (14.47 ft) lift height mast, Non-sideshift carriage and 2.44 m (8.0 ft) long forks

Capacities

Item	Quantity
Engine Oil	34.0 liter (36 qt)
Cooling System	40 liter (42.0 qt)
Hydraulic Tank	605 liter (160 gal)
Transmission	62.0 liter (66 qt)
Drive Axle and Differential	64.8 liter (68.5 qt)
Fuel Tank	670 liter (177 gal)

Electrical System

24 Volt, Negative Ground
Alternator Output 70 Amps

Engine Specifications (Cummins QSM11)

Item	Specification
Number of Cylinders	6
Firing Order	1-5-3-6-2-4
Bore	125 mm (4.92 in.)
Stroke	147 mm (5.79 in.)
Displacement	10.8 liter (659.10 in. ³)
Oil Pressure (Minimum at idle)	70 kPa (10.15 psi)
Governed Speed (No load)	2130 rpm
Idle Speed	750-800 rpm
Stall Speed	1950 rpm
Valve Clearance (Cold)	
Intake	0.36 mm (0.014 in.)
Exhaust	0.68 mm (0.027 in.)
Weight (Dry)	940 kg (2072 lb)

Mast Weights

Maximum Lift Height (mm/in)	Weight
4267 mm (168 in.)	9372 kg (20,665 lb)
7010 mm (276 in.)	11,960 kg (26,367 lb)
8534 mm (336 in.)	13,155 kg (29,006 lb)
9144 mm (360 in.)	13,729 kg (30,273 lb)
9754 mm (384 in.)	14,004 kg (30,874 lb)
12,654 mm (498 in.)	N/A

Lifting and Lowering Speeds

All Models	Lifting Speeds				Lowering Speeds			
	No Load		Rated Load		No Load		Rated Load	
Engine Type	m/sec	ft/min	m/sec	ft/min	m/sec	ft/min	m/sec	ft/min
300 HP (224 KW)	0.30	59	0.24	49	0.50	98	0.50	98
335 HP (250 KW)	0.30	59	0.26	51	0.50	98	0.50	98

Tires

Model	Size					Pressure
	Steer			Drive		
	16 x 25	18 x 25	18 x 33	18 x 25	18 x 33	
H40.00XM-12	X	X		X		10 bar (145 psi)
H44.00XM-12	X	X		X		
H48.00XM-12	X	X		X		
H800HD	X	X		X		
H900HD	X	X		X		
H970HDS	X	X		X		
H1050HD		X	X	X	X	
H1050HDS		X	X	X	X	

Forks

Size mm	Size inches	kg	lb
140 × 300 × 2185 Low Mount	5.5 × 12.0 × 86 Low Mount	2572	5670
140 × 300 × 2440 Low Mount	5.5 × 12.0 × 96 Low Mount	2676	5900

Hydraulic System Specifications

Item	Specification
Hydraulic Pumps Output @ 2100 rpm (Governed speed-no load)	
Cummins 300HP (224 KW)/335HP (250 KW) Engine	
Steering Pump [132.5 cm ³ (8.09 in. ³) per revolution]	284 liter/min (75 gal/min)
Lift Pump [52.5 cm ³ (3.2 in. ³) per revolution]	112 liter/min (30 gal/min)
Accumulator Circuit Pump [41.8 cm ³ (2.55 in. ³) per revolution]	90 liter/min (24 gal/min)
Cooling Pump [48 cm ³ (2.94 in. ³) per revolution]	103 liter/min (27 gal/min)
Relief Valve (approximate operating pressure)	
Main Control Valves	
Single Spool (Auxiliary/Lift Relief)	23.5 MPa (3408 psi)
Two Spool (Lift/Tilt Relief)	23.5 MPa (3408 psi)
Tilt Impact Relief	25 MPa (3626 psi)
Accumulator Circuit (Lift)	23.5 MPa (3408 psi)
Pilot Circuit	5.0 MPa (725 psi)
Parking Brake Circuit	17.0 MPa (2466 psi)
Steering Circuit	21.5 MPa (3118 psi)
Sideshift Circuit	12.4 MPa (1798 psi)
Check Port Pressures	
M1 - Steering Circuit at 2100 rpm	21.0 to 22.5 MPa (3046 to 3264 psi)
M2 - Lift/Lower Circuit at 2100 rpm	23 to 24.5 MPa (3336 to 3553 psi)
M3 - Tilt Circuit at 2100 rpm	23 to 24.5 MPa (3336 to 3553 psi)
M - ACC- Accumulator Charge Valve (Lower Limit)	16.0 to 17.5 MPa (2321 to 2538 psi)
M - ACC - Accumulator Charge Valve (Upper Limit)	20.0 to 21.5 MPa (2901 to 3118 psi)
M P - Auxiliary Circuit at 2100 rpm	23 to 24.5 MPa (3336 to 3553 psi)
M PLT - Pilot Circuit at 2100 rpm	4.5 to 5.0 MPa (653 to 725 psi)
M SB1 - Service Brake Pressure at 2100 rpm	16.5 to 17.0 MPa (2393 to 2466 psi)
M SB4 - Service Brake Treadle at 2100 rpm	Maximum 16.0 MPa (2321 psi)
M RF - Pressure at 2100 rpm fully lowered speed and oil temp 60°C (140°F) or higher.	Maximum 250 kPa (36 psi)
Main Hydraulic Filters	
Bypass Pressure	250 to 350 kPa (36 to 51 psi)

Torque Specifications

CONTROL VALVES

Main Control Valves

(Bolts and Nuts that Fasten Sections)
80 N•m (59 lbf ft)

Remote Control Valves

Screw of Pin Set 1.4 N•m (12 lbf in)
Plate Screws 5 N•m (44 lbf in)
Lock Nut of Hand Lever 30 N•m (266 lbf in)
Nuts of Through Bolts 5 N•m (44 lbf in)
Lock Nut of Adjustment Screw 5 N•m (44 lbf in)

Attachment Control Valve

Cover Capscrews 11 N•m (97 lbf in)
Mount Capscrews 14 N•m (124 lbf in)
Solenoids Capscrews 2.3 N•m (20 lbf in)
Pilot Valve Mount Capscrews 9 N•m (80 lbf in)

Carriage Solenoid Valves

Solenoid Capscrews 6.3 N•m (56 lbf in)
Mount Capscrews 14 N•m (124 lbf in)

ELECTRICAL SYSTEM

Alternator

Shaft Nut 95 to 108 N•m (70 to 80 lbf ft)
Mount Bolt 81 to 95 N•m (60 to 70 lbf ft)
Battery (B+) Terminal 9.0 to 13.6 N•m
(80 to 120 lbf in)
Indicator (I) Terminal 1.7 to 2.8 N•m
(15 to 25 lbf in)
Ground (B-) Terminal 5.6 to 6.8 N•m
(50 to 60 lbf in)

COUNTERWEIGHT (FABRICATED)

Main Counterweight

Tie Rod Weldments (Top) 1500 N•m (1106 lbf ft)
Tie Rod Weldments (Rear) 1500 N•m (1106 lbf ft)

COUNTERWEIGHT (SECONDARY)

Counterweight (Secondary)

Mount Capscrews 66 N•m (49 lbf ft)

COUNTERWEIGHT (SLAB)

Counterweight (Slab)

Mount Capscrews 600 N•m (443 lbf ft)

DRIVE AXLE

Mounting Bolts

1650 to 2050 N•m (1220 to 1515 lbf ft)

WHEEL BEARING ADJUSTING NUT

PRC-5324 to 7314 (Initial Torque Value)

813 N•m (600 lbf ft)

PRC-5324 to 7314 (Final Torque Value)

678 N•m (500 lbf ft)

PRC-7534 (Initial Torque Value)

949 N•m (700 lbf ft)

PRC-7534 (Final Torque Value)

746 N•m (550 lbf ft)

DIFFERENTIAL

See the section **Differential** 1400 SRM 46.

TRANSMISSION

See the section **Transmission, (TE27 and TE32)**
1300 SRM 1220.

TORQUE CONVERTER

See the section **Transmission, (TE27 and TE32)**
1300 SRM 1220.

STEERING

Steering Shaft Nut for Steering Wheel

35 to 45 N•m (26 to 33 lbf ft)

Block of Steering Control Unit

40 N•m (30 lbf ft)

Steering Cylinder Mounting Nuts (Lubed)

1410 to 1590 N•m (1040 to 1173 lbf ft)

Spindle Bearing Cup for Lower Pivot

Bearings 47 N•m (35 lbf ft) Initial, then 0 N•m
(0 lbf ft), then just to zero clearance

Hub Cover Capscrews

45.1 N•m (33 lbf ft)

Wheel Hub Capscrews

333.5 N•m (246 lbf ft)

Spindle Plate Capscrews

383 N•m (283 lbf ft)

Retainer Plate Capscrews

200 N•m (148 lbf ft)

Adjusting Nut

93.2 to 127.5 N•m (68.8 to 94 lbf ft)

WHEEL NUTS

Rim Nuts for Drive Wheels (Final Torque Value)

405 to 440 N•m (299 to 325 lbf ft)

Rim Nuts for Steer Wheels (Final Torque Value)

271 to 339 N•m (200 to 250 lbf ft)

CARRIAGES (ALL)

Solenoid Valve to Manifold

15 N•m (11 lbf ft)

End Cap of Load Roller (Before Shims)

50 N•m (35 lbf ft) Initial, then 0 N•m (0 lbf ft),
then just to zero clearance

End Cap of Load Roller (After Shims)

110 to 115 N•m (80 to 85 lbf ft)

Solenoid Valve to Manifold

15 N•m (11 lbf ft)

