

# **PARTS MANUAL**

---

## **SPACESAVER**

**S25-35XM S40XMS  
(D010)**

CUSTOMER EDITION

---

# ***HYSTER***

**SECTIONS**

<b>1</b>	<b>FRAME</b>
<b>2</b>	<b>ENGINES</b>
<b>3</b>	<b>FUEL SYSTEM</b>
<b>4</b>	<b>ELECTRICAL SYSTEM</b>
<b>5</b>	<b>TRANSMISSION</b>
<b>6</b>	<b>STEERING SYSTEM</b>
<b>7</b>	<b>BRAKE SYSTEM</b>
<b>8</b>	<b>HYDRAULIC SYSTEM</b>
<b>9</b>	<b>MAST-TWO STAGE LIMITED FREE-LIFT</b>
<b>10</b>	<b>MAST-TWO STAGE FULL FREE-LIFT</b>
<b>11</b>	<b>MAST-THREE STAGE FULL FREE-LIFT</b>
<b>12</b>	<b>OPTIONS</b>
<b>13</b>	<b>NUMERICAL INDEX</b>

This Parts Manual is divided into 13 major sections which are listed above. Quick reference to these sections can be made by placing the right thumb on the tab of the desired section, bending the book back and thumbing the pages to the corresponding tab.

**1**

**FRAME**

**SECTION 1**  
**FRAME**

<b>DESCRIPTION</b>	<b>PAGE</b>
COUNTERWEIGHT .....	1-19
ENGINE COVER .....	1-6
FORKS .....	1-21
FRAME AND FLOORPLATE .....	1-2
LABELS .....	1-17
LOAD BACKREST EXTENSION .....	1-22
OVERHEAD GUARD .....	1-4
SEAT	
FULL SUSPENSION	
SHEET 1 OF 2 .....	1-8
SHEET 2 OF 2 .....	1-10
NON-SUSPENSION .....	1-12
SEMI-SUSPENSION SEAT	
EUROPE .....	1-14

## FRAME AND FLOORPLATE (Figure 1-1)

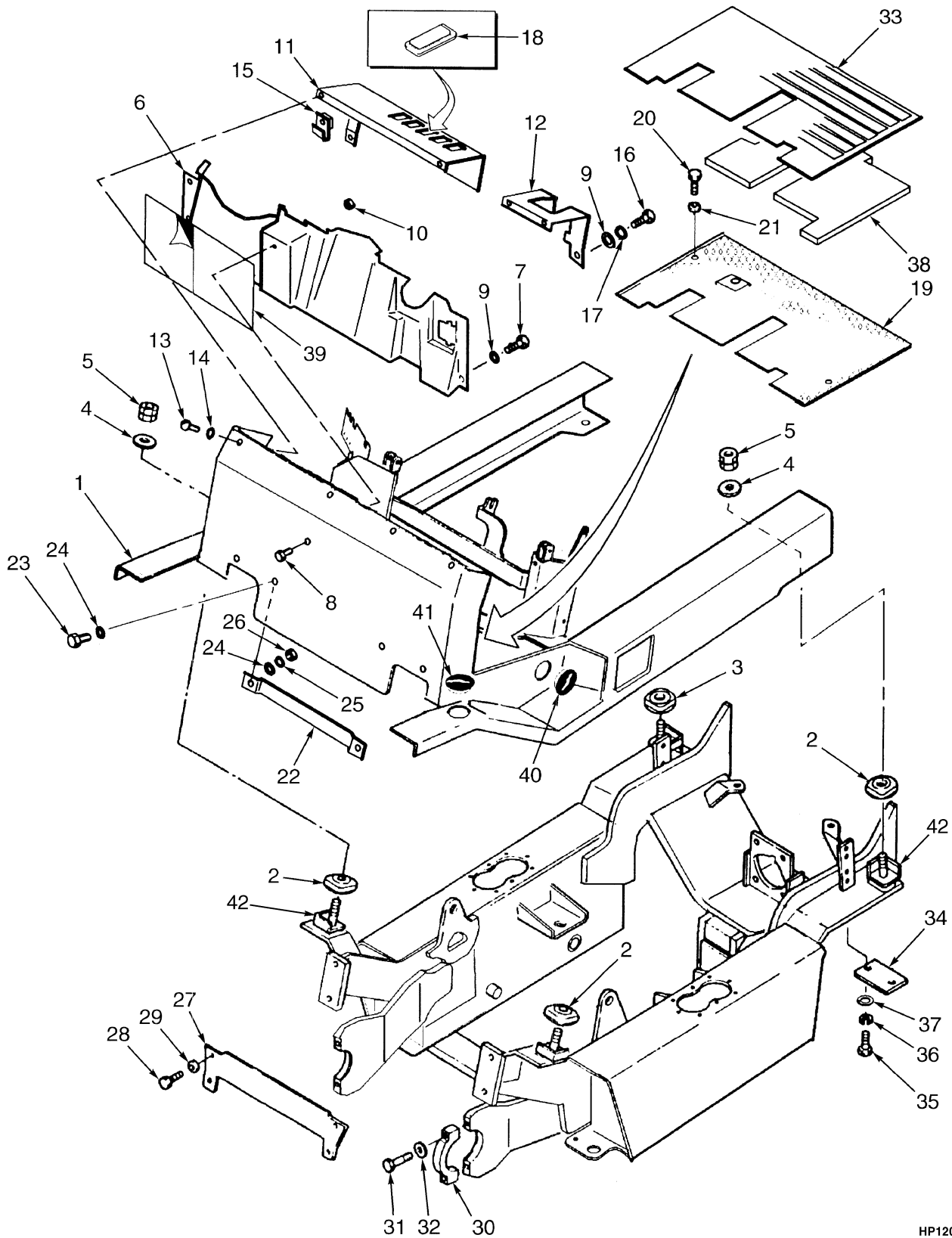

HP120527

**FRAME AND FLOORPLATE**

ITEM	PART NO.	DESCRIPTION	QTY
1	<b>b</b> 1477464	Operator Module (Standard).....	1
1	<b>b</b> 1477467	Operator Module (Wide Tread) .....	1
1	<b>a</b> 2041656	Operator Module (Standard).....	1
1	<b>a</b> 2041663	Operator Module (Wide Tread) .....	1
2	2021234	Isulator.....	3
3	2021235	Isulator.....	1
4	2021238	Washer .....	4
5	2021237	Nut .....	4
6	2021232	Cover .....	1
7	316678	Screw.....	4
8	292501	Capscrew.....	1
9	320156	Washer .....	3
10	1359600	Nut .....	1
11	<b>c</b> 1385097	Panel (RH) .....	1
11	2021497	Panel (RH) .....	1
12	2021499	Panel (LH).....	1
13	369242	Capscrew.....	4
14	292681	Lockwasher.....	4
15	1350282	Nut .....	4
16	316678	Screw.....	2
17	292681	Lockwasher.....	2
18	376949	Cover .....	AR
19	2023789	Floorplate.....	1
20	136681	Capscrew.....	2
21	15175	Washer .....	2
22	2021231	Bracket.....	1
23	176640	Capscrew.....	2
24	320157	Washer .....	4
25	292681	Lockwasher.....	2
26	239503	Nut .....	2
27	2022897	Plate .....	1
28	2022636	Capscrew.....	4
29	296426	Washer (Hardened) .....	4
30	2021833	Cap .....	2
31	292533	Capscrew.....	4
32	2021834	Washer .....	4
33	2022821	Floormat .....	1
34	2021900	Cover .....	2
35	136985	Capscrew.....	4
36	292682	Lockwasher.....	4
37	320159	Washer .....	4
38	2022822	Barrier.....	1
39	2022798	Label.....	1
40	2022803	Cap (Tilt Pin).....	2
41	2021395	Cap .....	2
42	2047056	Support (Rubber) (Lower).....	4

**FOOTNOTES:**

- a** Gasoline
- b** LPG
- c** Type GS/LPS

## OVERHEAD GUARD (Figure 1-2)

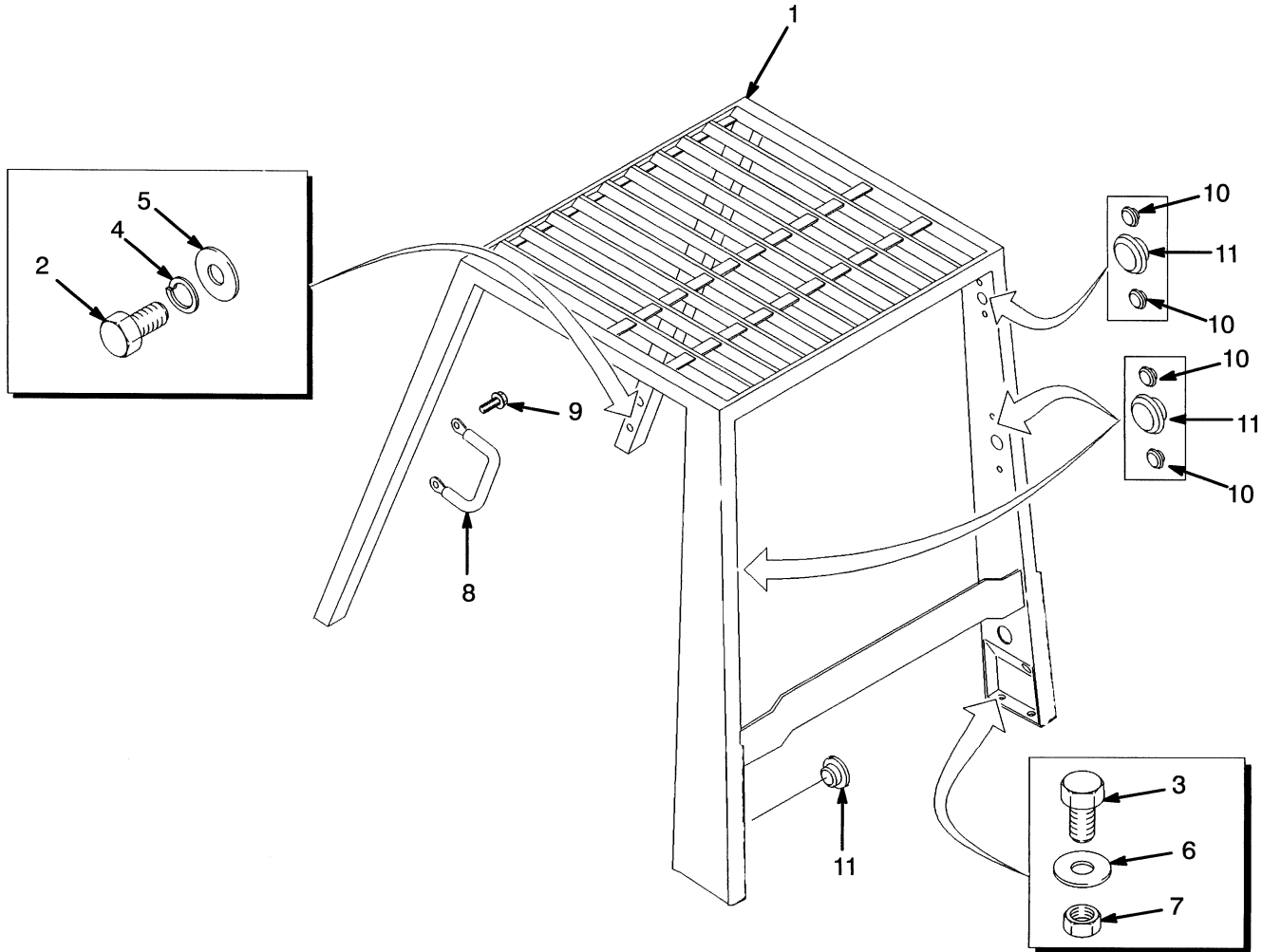

HP120528

ITEM	PART NO.	DESCRIPTION	QTY
1	2026479	Overhead Guard (Lowered) .....	1
1	2042988	Overhead Guard (Raised) .....	1
2	132860	Capscrew .....	4
3	292528	Capscrew .....	2
4	292683	Lockwasher .....	4
5	15177	Washer .....	4
6	320161	Washer .....	2
7	300937	Locknut .....	2
8	1343647	Handle .....	1
9	329067	Screw .....	2
10	1363916	Plug .....	12
11	1363917	Plug .....	4

## ENGINE COVER (Figure 1-3)

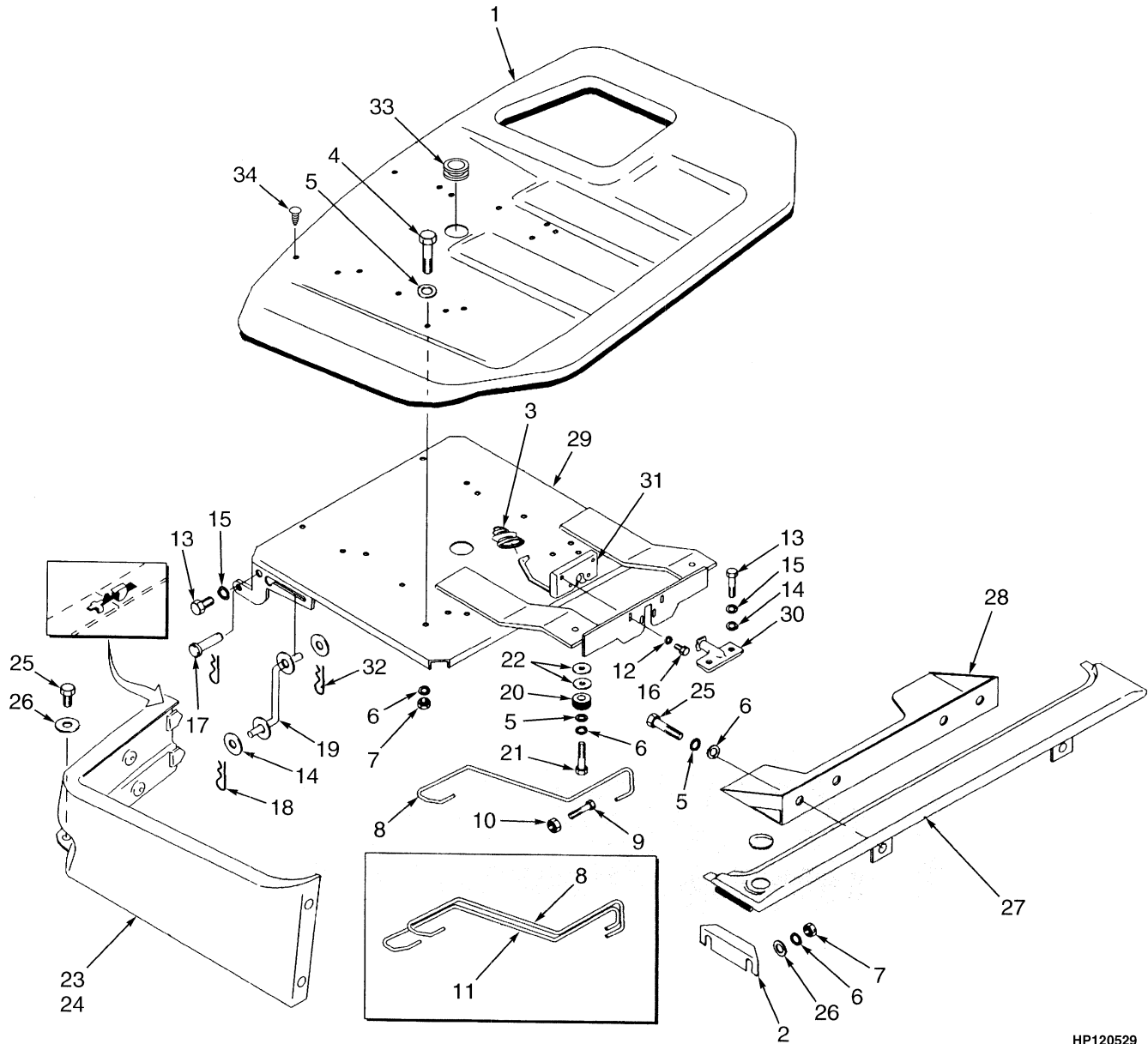

HP120529



**ENGINE COVER****KEY:****A: Non Suspension Seat****B: Suspension Seat**

ITEM	PART NO.	DESCRIPTION	QTY	
			A	B
1	2021197	Engine Cover .....	1	1
2	2022809	Support .....	2	2
3	1339786	Boot .....	1	1
4	176640	Capscrew .....	2	2
5	320157	Washer .....	6	6
6	292681	Lockwasher .....	12	12
7	239503	Nut .....	6	6
8	2026073	Spring .....	..	1
9	136749	Capscrew .....	2	2
10	239503	Nut .....	2	2
11	2026074	Spring .....	1	1
12	320156	Washer .....	4	4
13	<b>a</b> 287854	Capscrew .....	2	2
13	<b>b</b> 292514	Capscrew .....	2	2
14	320159	Washer .....	6	6
15	292682	Lockwasher .....	2	2
16	199563	Capscrew .....	4	4
17	2021207	Pin .....	2	2
18	1362714	Cotter Pin .....	2	2
19	2021208	Bracket .....	1	1
20	2021213	Cushion (Rubber) .....	2	2
21	296167	Capscrew .....	2	2
22	15177	Washer .....	AR	AR
23	2023466	Panel (RH) .....	1	1
24	2021216	Panel (LH) .....	1	1
25	329067	Screw .....	4	4
26	15175	Washer .....	10	10
27	2021218	Cover .....	1	1
28	2021219	Bracket .....	1	1
29	<b>c</b> 1498410	Seat Pan .....	1	1
29	<b>d</b> 1389607	Seat Pan .....	1	1
30	1337148	Striker Plate .....	1	1
31	2021222	Latch .....	1	1
32	15222	Cotter Pin .....	1	1
33	1359587	Grommet .....	1	1
34	1347045	Fastener .....	4	4

**FOOTNOTES:****a** ⇒ S/N D010H-02444Z**b** S/N D010H-02445Z ⇒**c** ⇒ D/B 05/2001**d** D/B 05/2001 ⇒

## SEAT (Figure 1-4) FULL SUSPENSION SHEET 1 OF 2

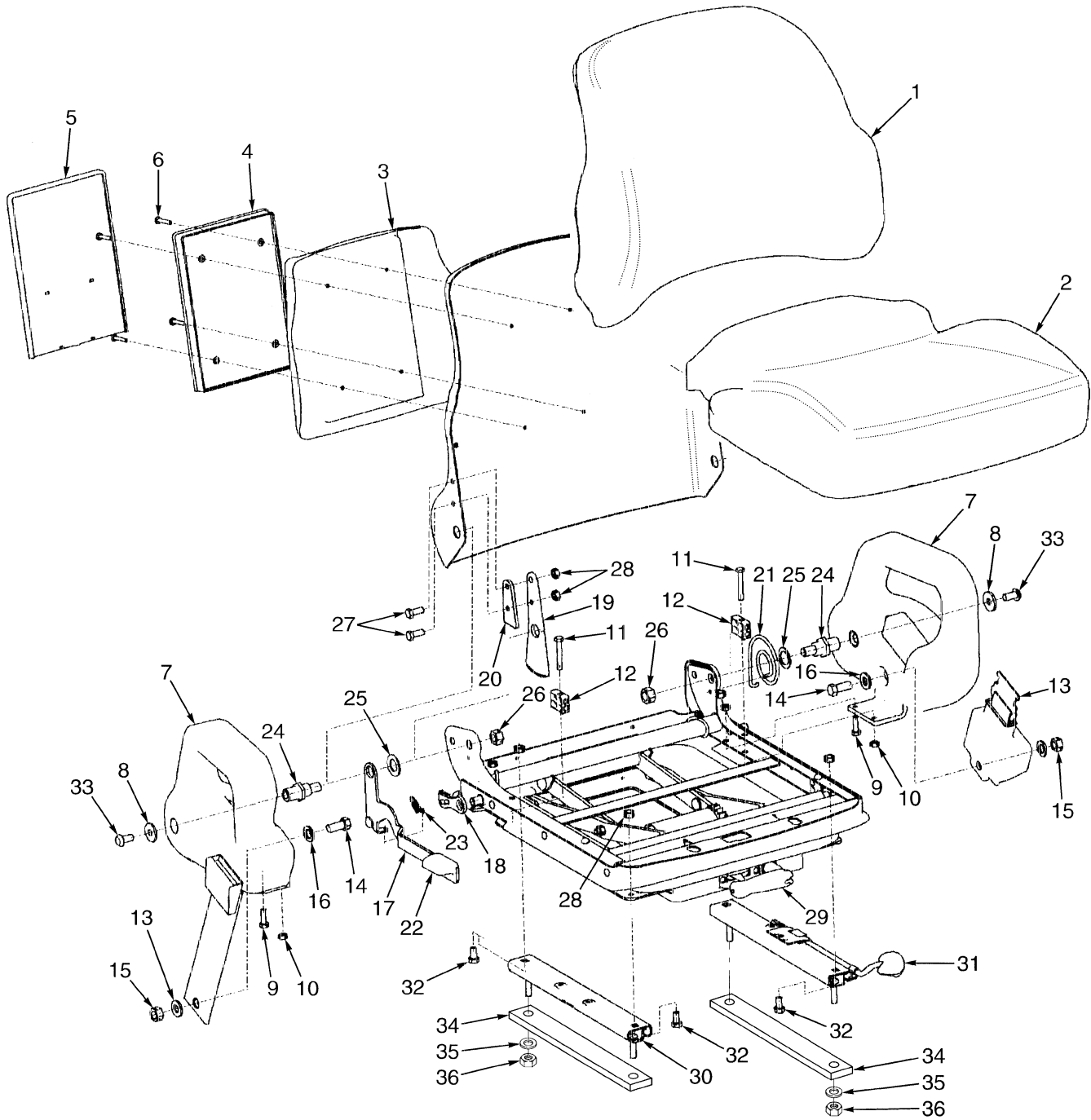

HP120530

**SEAT  
FULL SUSPENSION  
SHEET 1 OF 2**

ITEM	PART NO.	DESCRIPTION	QTY
	1476713	Suspension Seat (Vinyl) .....	1
	1476714	Suspension Seat (Fabric) .....	1
1	1470152	Back Cushion (Vinyl) .....	1
1	1470153	Back Cushion (Cloth) .....	1
2	1467534	Seat Cushion (Vinyl).....	1
2	1470154	Seat Cushion (Fabric) .....	1
3	.....	Riser .....	1
4	.....	Box .....	1
5	.....	Cover .....	1
6	.....	Screw .....	4
7	.....	Hip Restraint (RH) .....	1
7	.....	Hip Restraint (LH).....	1
8	.....	Washer .....	2
9	.....	Bolt .....	2
10	.....	Nut.....	4
11	.....	Bolt .....	2
12	.....	Block.....	2
13	.....	Seat Belt.....	1
14	.....	Bolt .....	2
15	.....	Nut.....	2
16	.....	Washer .....	4
17	.....	Handle .....	1
18	.....	Latch.....	1
19	.....	Bracket .....	1
20	.....	Spacer .....	1
21	.....	Spring.....	1
22	.....	Knob.....	1
23	.....	Spring Extension .....	1
24	.....	Pivot .....	2
25	.....	Washer .....	2
26	.....	Nut.....	2
27	.....	Bolt .....	2
28	.....	Nut.....	6
29	1470163	Weight Adjuster Kit.....	1
30	.....	Slide (RH).....	1
31	.....	Slide (LH) .....	1
32	.....	Bolt .....	4
33	.....	Screw .....	2
34	2026092	Spacer .....	2
35	15175	Washer .....	4
36	145639	Nut .....	4
	1470155	Manual Holder Kit (Includes Items 3-6) .....	1
	1470156	Hip Restraint Kit (RH) (Includes Items 7-12, 33) .....	1
	1470157	Hip Restraint Kit (LH) (Includes Items 7-12, 33) .....	1
	1470158	Seat Belt Kit (Includes Items 13-16) .....	1
	1470164	Recliner Kit (Includes Items 17-28) .....	1
	1470161	Slide Kit (Includes Items 30-32).....	1
	893818	Ground Wire (Not Illustrated).....	1

## SEAT (Figure 1-5) FULL SUSPENSION SHEET 2 OF 2

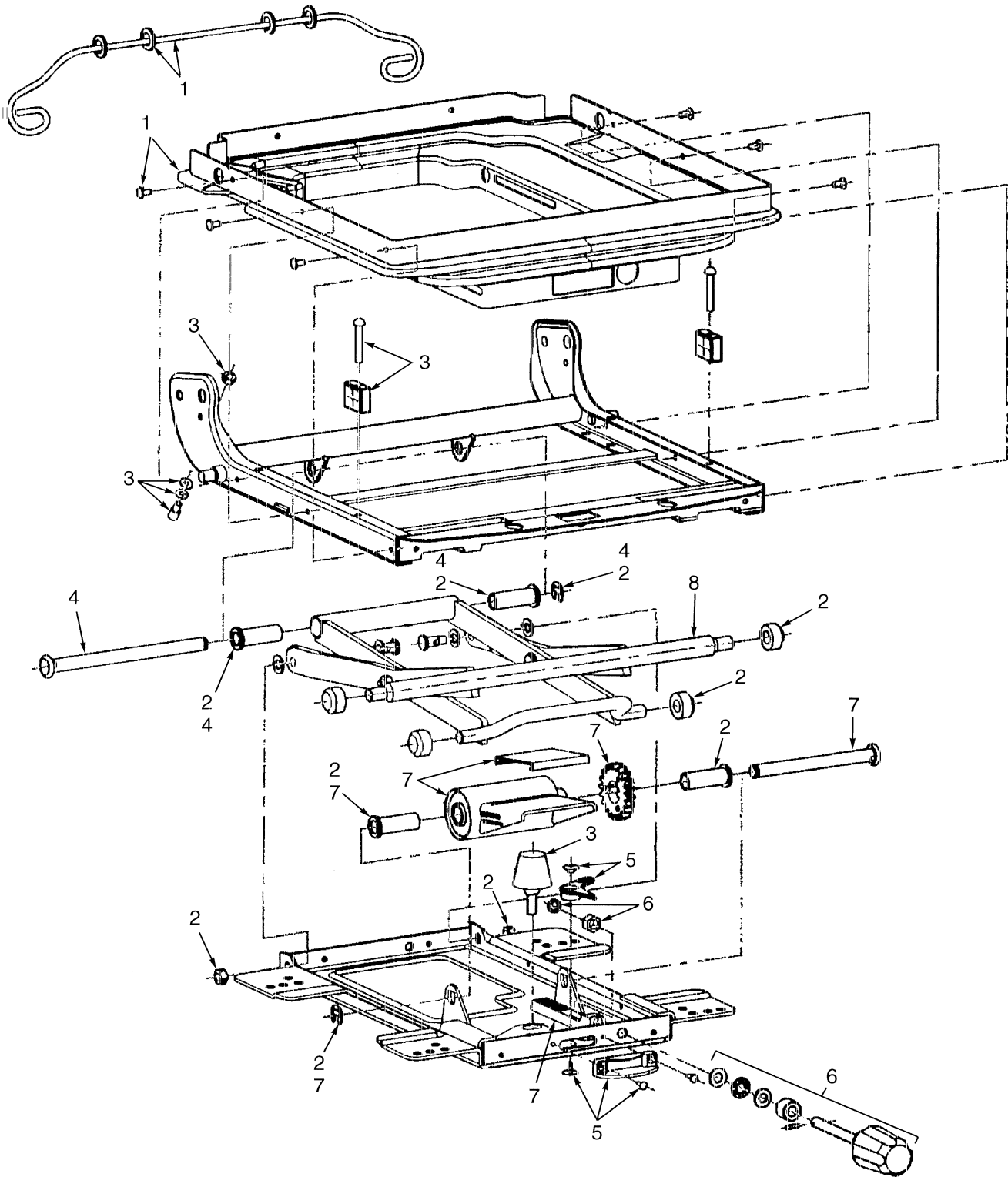

HP120531

**SEAT  
FULL SUSPENSION  
SHEET 2 OF 2**

ITEM	PART NO.	DESCRIPTION	QTY
	1476712	Seat (Fabric) .....	1
	1476711	Seat (Vinyl) .....	1
1	1467523	Boot Kit.....	1
2	1467524	Roller and Bearing Kit .....	1
3	1467525	Bumper and Stop Kit .....	1
4	1467526	Bearing Shaft Kit .....	1
5	1467527	Weight Adjuster Indicator Kit .....	1
6	1467531	Recliner Knob.....	1
7	1467529	Suspension Spring Kit.....	1
8	1470160	Scissor Assembly .....	1

## SEAT (Figure 1-6) NON-SUSPENSION

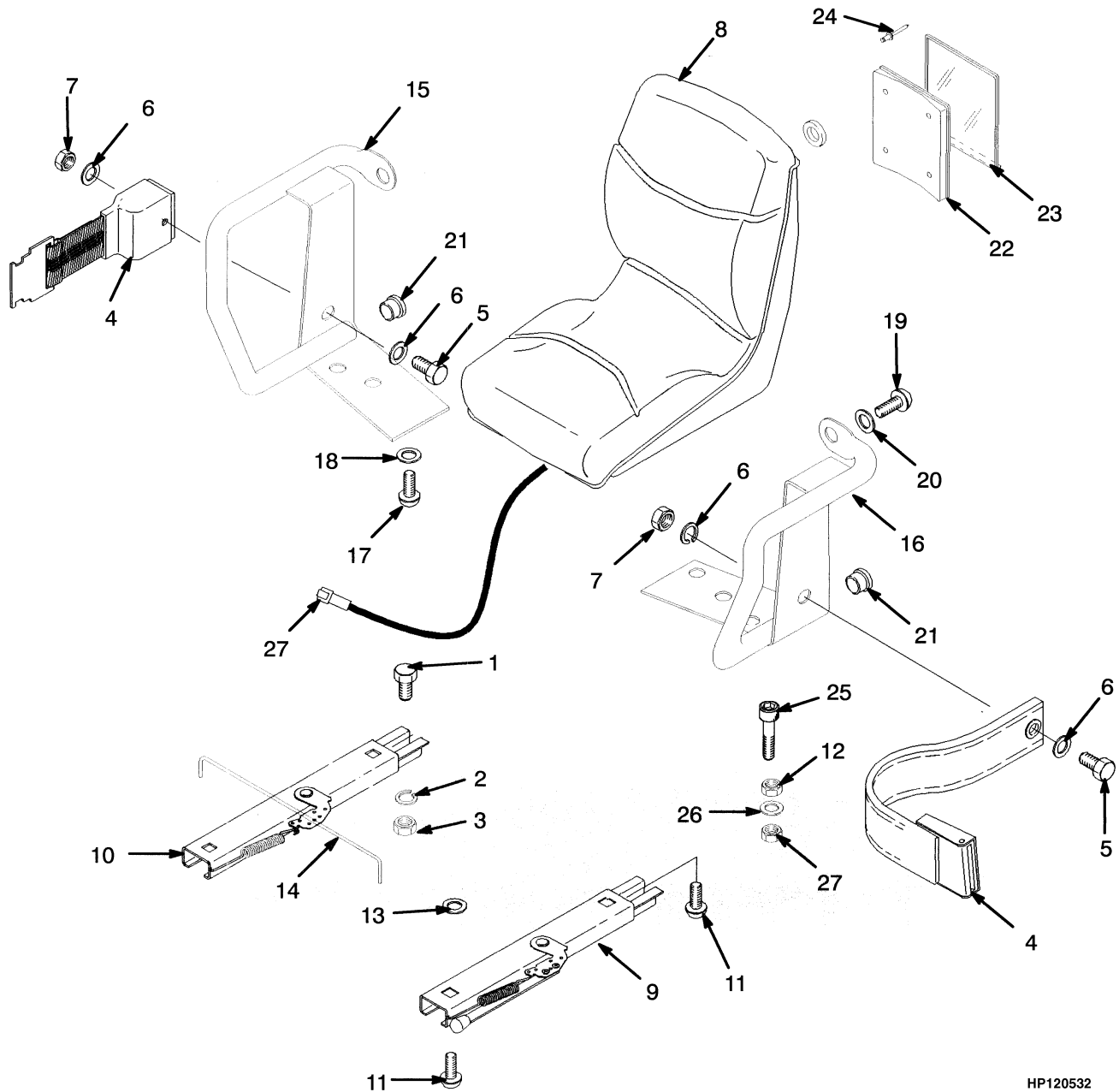

HP120532

**SEAT  
NON-SUSPENSION**

ITEM	PART NO.	DESCRIPTION	QTY
	1351473	Seat .....	1
1	18496	Capscrew .....	4
2	15175	Washer .....	4
3	145639	Nut.....	4
4	1374750	Seat Belt.....	1
5	379199	Capscrew .....	2
6	379697	Washer .....	4
7	379698	Nut.....	2
8	1351431	Seat.....	1
9	335553	Seat Rail (LH).....	1
10	383116	Seat Rail (RH) (RH).....	1
11	364914	Capscrew .....	4
12	296128	Nut (LPG) .....	2
13	221733	Washer .....	2
14	1300107	Rod.....	1
15	364807	Hip Restraint (RH) .....	1
16	364808	Hip Restraint (LH).....	1
17	18727	Capscrew .....	4
18	18515	Washer .....	4
19	379197	Capscrew .....	2
20	379198	Washer .....	2
21	364854	Plug .....	2
22	335988	Base (Information Case) .....	1
23	335991	Cover (Information Case) .....	1
24	222029	Rivet .....	4
25	296027	Capscrew (LPG).....	1
26	15176	Washer (LPG) .....	1
27	1354140	Switch Assembly .....	1

## SEMI-SUSPENSION SEAT (Figure 1-7) EUROPE

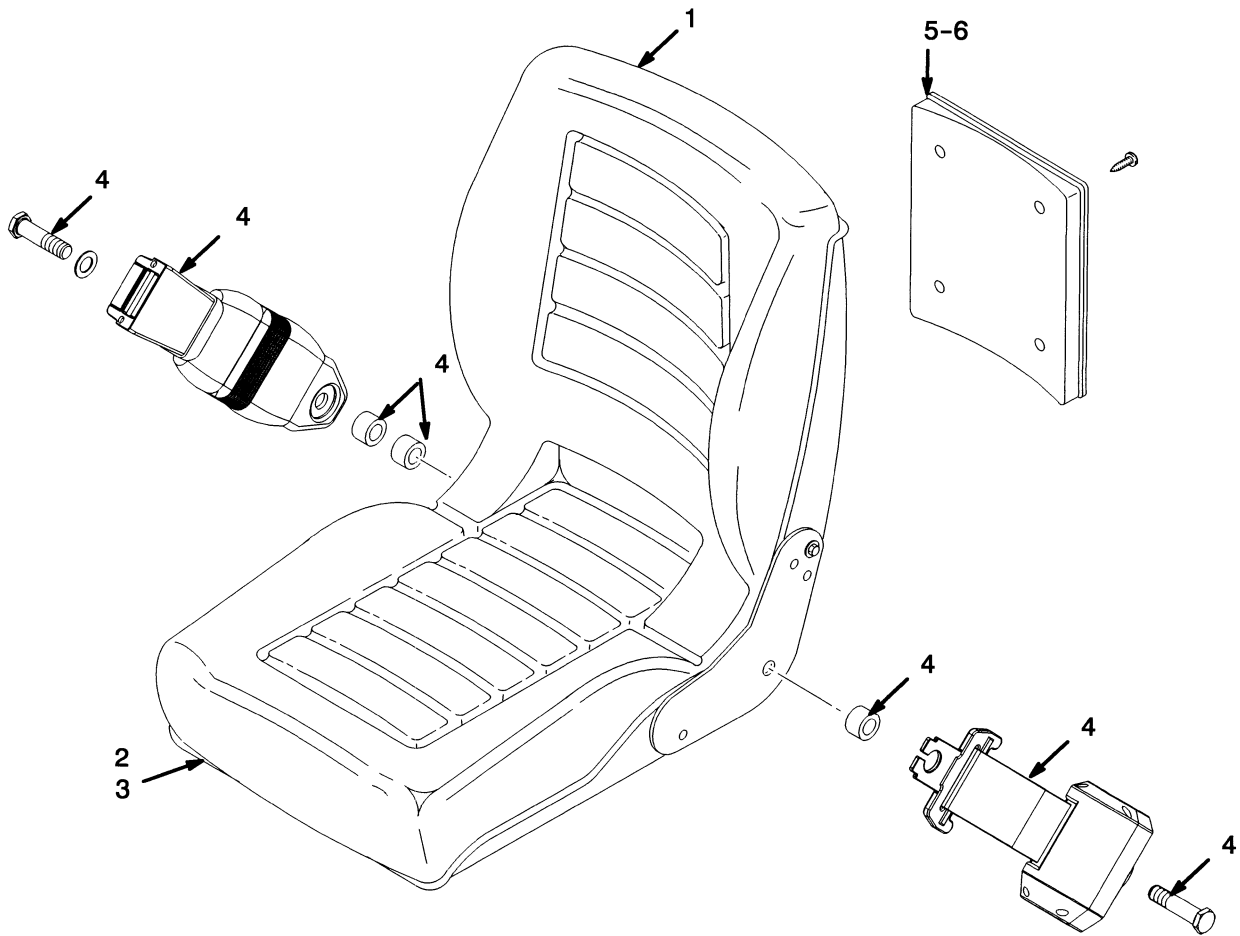

HP120325



**SEMI-SUSPENSION SEAT  
EUROPE**

ITEM	PART NO.	DESCRIPTION	QTY
	2051298	Semi-Suspension Seat .....	1
1	1480403	Back Cushion .....	1
2	1480404	Seat Cushion (With Switch).....	1
3	<b>a</b> 1480405	Slider Kit .....	1
4	1461081	Seat Belt Kit.....	1
5	335989	Base (Information Case) .....	1
6	335991	Cover (Information Case) .....	1

**FOOTNOTES:****a** Not Illustrated

## LABELS (Figure 1-8)

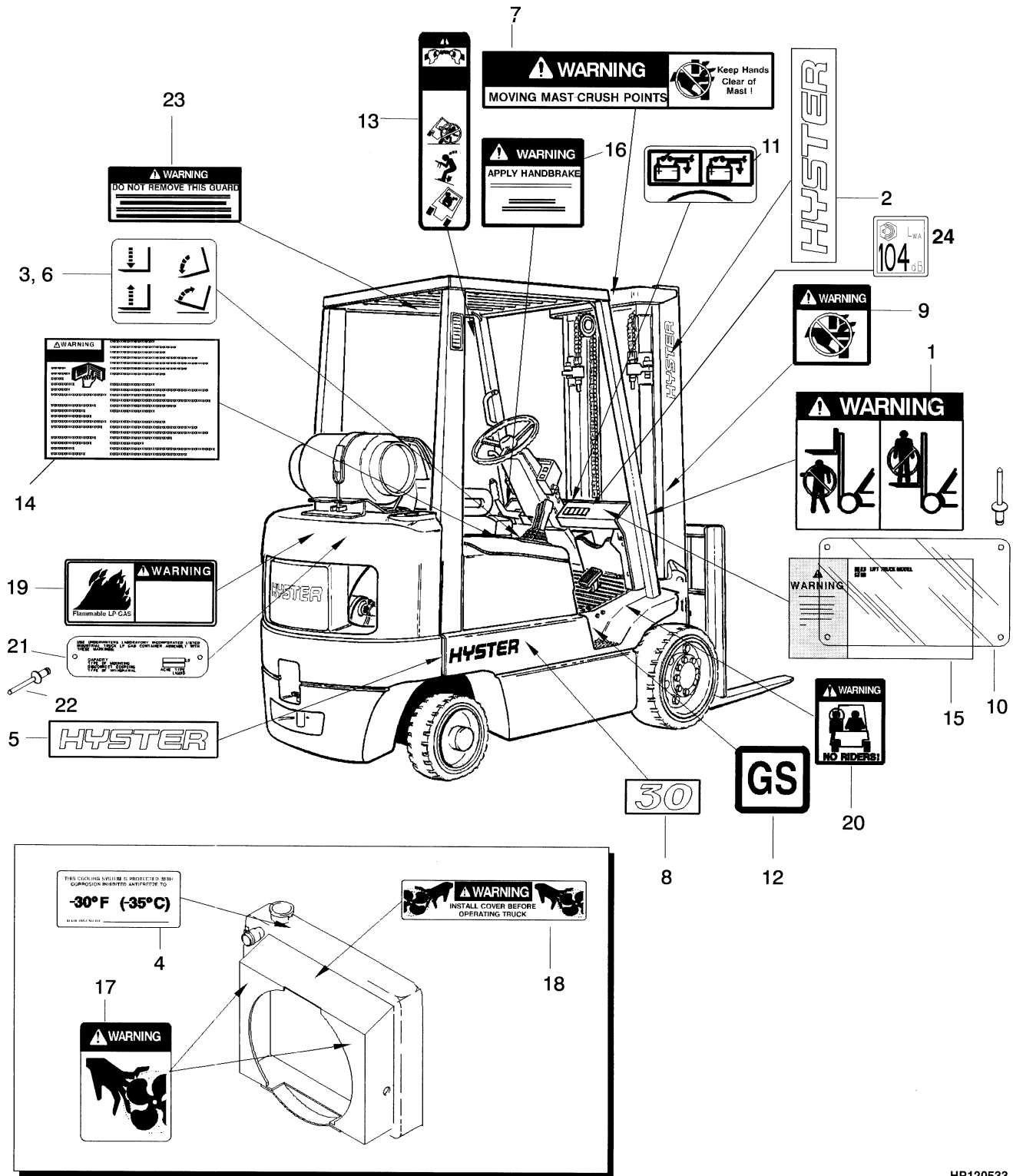

HP120533

**LABELS**

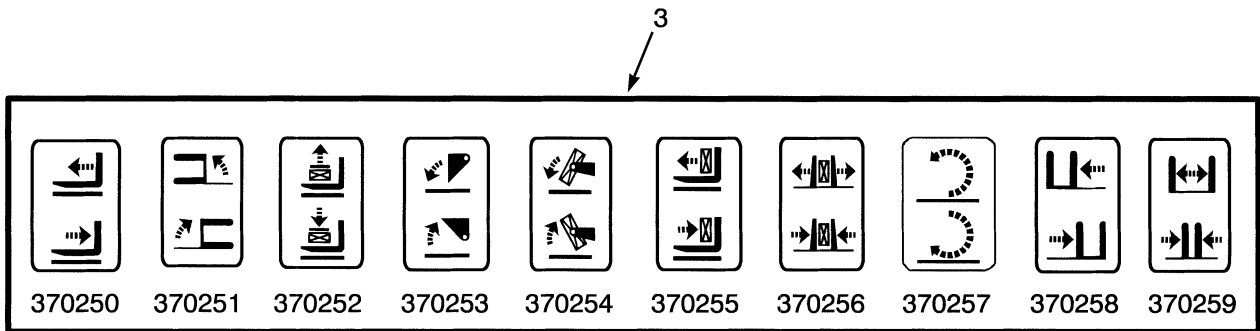

HP120534

ITEM	PART NO.	DESCRIPTION	QTY
1	1338178	Label (Mast Warning) .....	2
2	1339672	Label (Hyster) (Vertical).....	2
3	370250	Label (Auxiliary Function - Reach) .....	AR
3	370251	Label (Auxiliary Function - Swing).....	AR
3	370252	Label (Auxiliary Function - Stabilizer) .....	AR
3	370253	Label (Auxiliary Function - Dump/Scoop) .....	AR
3	370254	Label (Auxiliary Function - Upender).....	AR
3	370255	Label (Auxiliary Function - Push/Pull).....	AR
3	370256	Label (Auxiliary Function - Clamp) .....	AR
3	370257	Label (Auxiliary Function - Rotate).....	AR
3	370258	Label (Auxiliary Function - Side-Shift) .....	AR
3	370259	Label (Auxiliary Function - Fork Spreader).....	AR
4	1354165	Label (Anti-freeze) .....	1
5	2020517	Label (Hyster) .....	2
6	1356137	Label (Lift and Tilt).....	1
7	1330919	Label (Mast Warning) .....	1
8	2020513	Label (Model 25).....	2
8	2020514	Label (Model 30).....	2
8	2020515	Label (Model 35).....	2
8	2020516	Label (Model 40).....	2
9	1335129	Label (Pinch Point) .....	2
10	389688	Cover .....	1
11	1352190	Label (Battery Disconnect) (Type GS and LPS) .....	1
12	154065	Label (Type GS).....	2
12	154066	Label (Type LPS) .....	2
13	1330917	Label (Operator Restraint) .....	2
14	1336605	Label (Operator Warning).....	1
15	a 1381125	Label (Nameplate) .....	1
16	2309799	Label (Parking Brake) .....	1
17	1345939	Label (Fan Warning) .....	2
18	1325271	Label (Fan Warning) .....	1
19	1354171	Label (Flammable LPG).....	1
20	1330920	Label (No Riders) .....	2
21	1501259	Label (LPG Tank).....	1
22	170658	Rivet.....	6

## LABELS

ITEM	PART NO.	DESCRIPTION	QTY
23	<b>a</b> . . . . .	Label (Overhead Guard).....	1
24	<b>b</b> 1503878	Label (Noise Level) (Non U.S.).....	1

**FOOTNOTES:**

- a** Contact Your Local Hyster Dealer
- b** Not Illustrated

**COUNTERWEIGHT (Figure 1-9)**

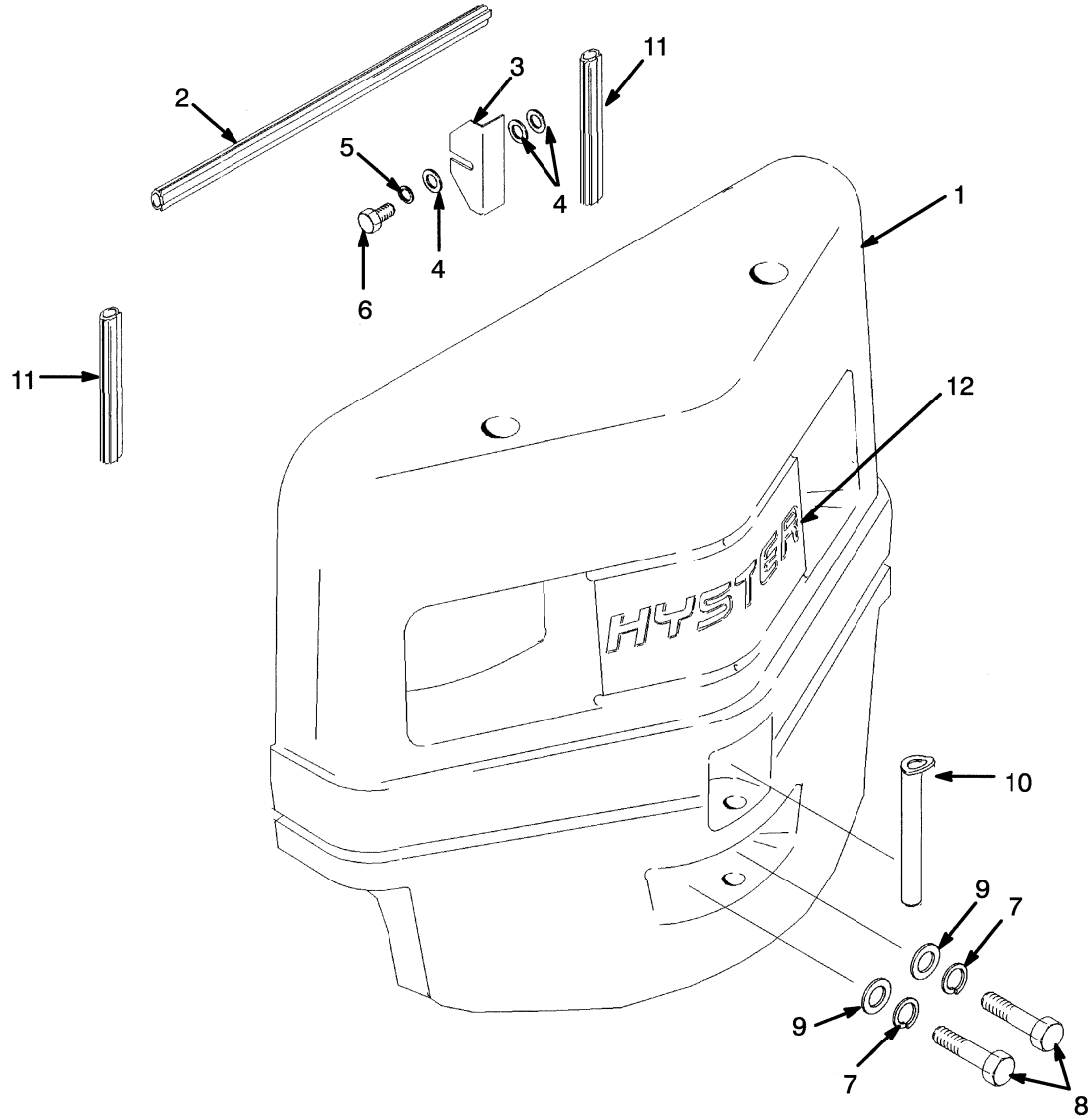

HP120535

## COUNTERWEIGHT

ITEM	PART NO.	DESCRIPTION	QTY
1	1469460	Counterweight (S30XM) .....	1
1	1469468	Counterweight (S35XM) .....	1
1	1469469	Counterweight (S40XMS).....	1
1	1469594	Counterweight (S25XM) .....	1
2	2022800	Seal .....	1
3	2021563	Shim .....	4
4	320158	Washer .....	4
5	292681	Lockwasher.....	4
6	287851	Capscrew.....	4
7	292689	Lockwasher.....	2
8	292609	Capscrew.....	2
9	2021562	Washer .....	2
10	2022849	Pin .....	1
11	2022799	Seal .....	2
12	a 1450409	Label (Hyster).....	1

**FOOTNOTES:**

a Counterweight Optional

**FORKS (Figure 1-10)**

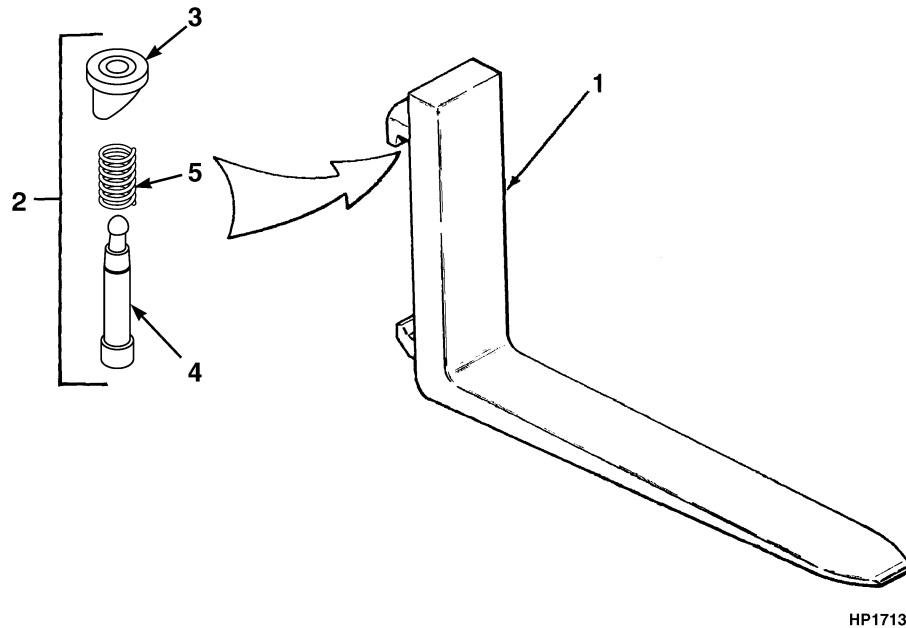

**KEY:**

**A: Standard Taper (40 mm x 100 mm)**

**B: Full Bottom Taper (40 mm x 100 mm)**

ITEM	PART NO.	DESCRIPTION	QTY	
			A	B
1	1338076	Fork (36 in.) .....	..	2
1	1338077	Fork (42 in.) .....	..	2
1	1338078	Fork (48 in.) .....	..	2
1	384211	Fork (36 in.) .....	2	..
1	384213	Fork (42 in.) .....	2	..
1	384214	Fork (48 in.) .....	2	..
1	384215	Fork (54 in.) .....	2	..
1	384216	Fork (60 in.) .....	2	..
2	1523735	Latch Kit (Class II) .....	2	2
3	1523732	Knob .....	1	1
4	1523733	Pin .....	1	1
5	1500782	Spring .....	1	1

## LOAD BACKREST EXTENSION (Figure 1-11)

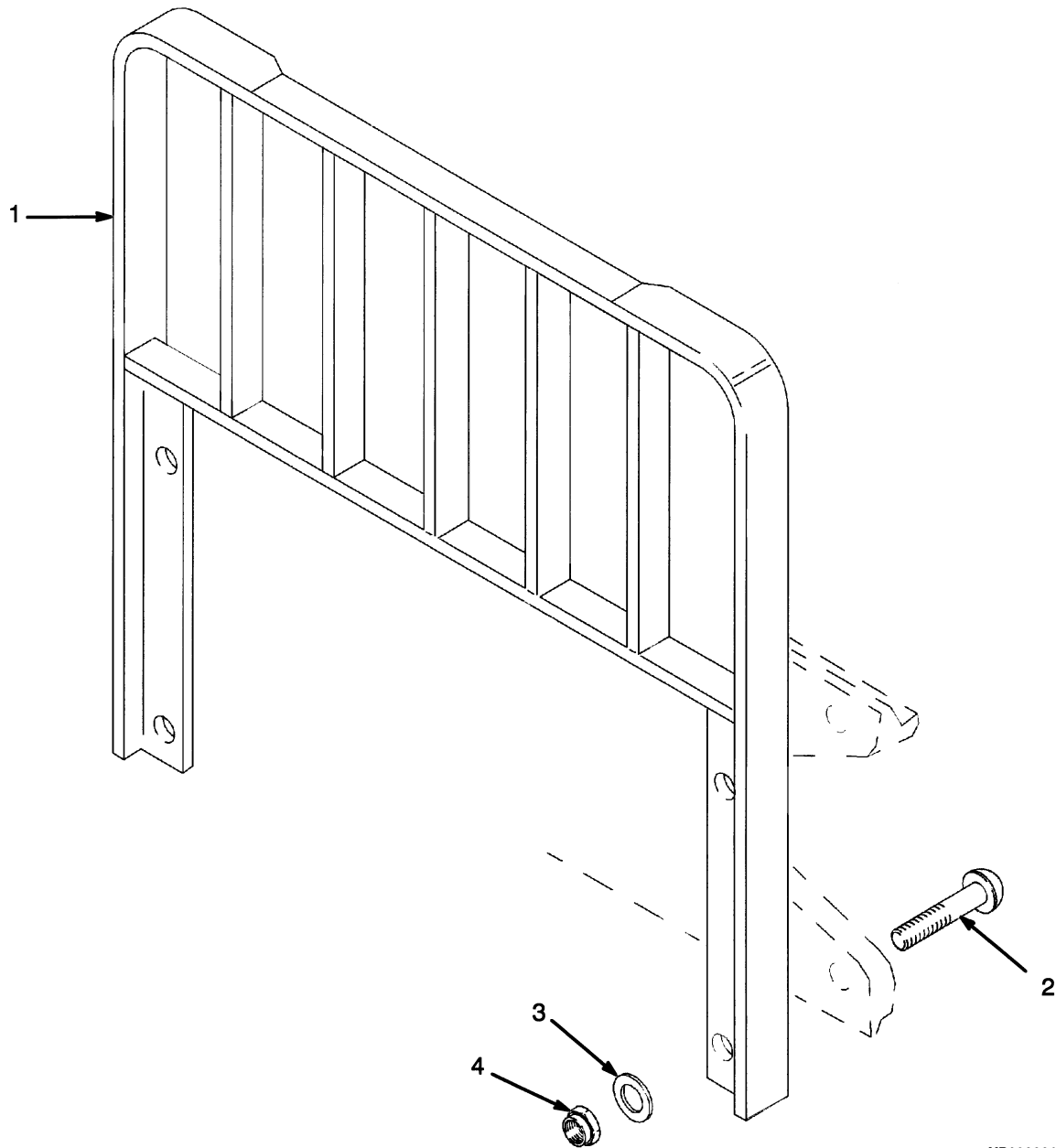

YP290001



**LOAD BACKREST EXTENSION**

<b>ITEM</b>	<b>PART NO.</b>	<b>DESCRIPTION</b>	<b>QTY</b>
1	1349440	Load Backrest Extension (35.7 in.).....	1
2	1343990	Capscrew (With Side-Shift).....	4
2	1353533	Capscrew (Without Side-Shift).....	4
3	221771	Washer .....	4
3	296423	Washer (Optional).....	4
4	300937	Locknut .....	4

**BUY NOW**

**Then Instant Download  
the Complete Manual  
Thank you very much!**