

# **CAPACITIES AND SPECIFICATIONS**

**S6.0FT, S7.0FT (S135FT, S155FT) [D024, E024];  
H6.0FT, H7.0FT (H135FT, H155FT) [H006, J006]**

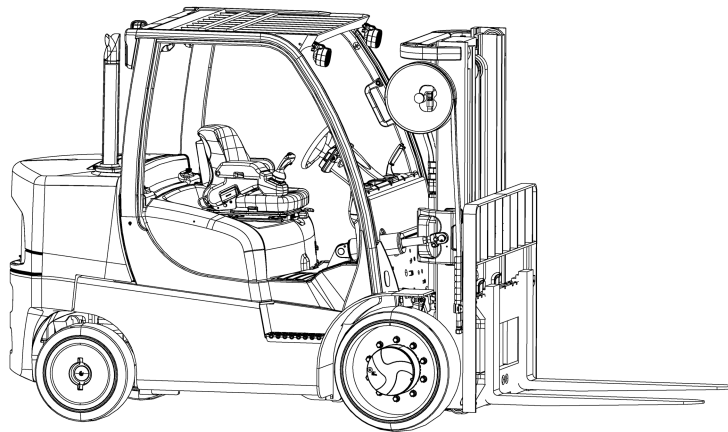

# ***HYSTER***

## TABLE OF CONTENTS

Lift Truck Lifting Capacity.....	1
Counterweight Weights .....	1
Tire Sizes .....	1
Capacities .....	1
Electrical System .....	7
Transmission Oil Pressures.....	9
Hydraulic System Relief Pressures.....	10
Steering System .....	11
Stall Speeds (in RPM ±100 rpm).....	11
GM 4.3L Gas S6.0FT, S7.0FT, (S135FT,S155FT) (D024, E024).....	11
GM 4.3L LPG S6.0FT, S7.0FT, (S135FT,S155FT) (D024, E024).....	12
GM 4.3L Gas H6.0FT, H7.0FT (H135FT, H155FT) (H006, J006) .....	12
GM 4.3L LPG H6.0FT, H7.0FT (H135FT, H155FT) (H006, J006) .....	12
Cummins 4.5L Diesel S6.0FT, S7.0FT, (S135FT,S155FT) (D024) .....	12
Cummins QSB 3.3L Diesel S6.0FT, S7.0FT, (S135FT,S155FT) (E024).....	13
Cummins 4.5L Diesel H6.0FT, H7.0FT (H135FT, H155FT) (H006).....	13
Cummins QSB 3.3L Diesel H6.0FT, H7.0FT (H135FT, H155FT) (J006) .....	13
Mast Speeds .....	14
Tilt Angles .....	16
Front End Equipment - Mast Creep .....	16
Mast Creep.....	16
Engine Specifications.....	17
Torque Specifications .....	19
Frame .....	19
Mast, Lift Truck Models S6.0FT, S7.0FT (S135FT, S155FT) (D024, E024) .....	19
Mast, Lift Truck Models H6.0FT, H7.0FT (H135FT, H155FT) (H006, J006).....	19
Steering System.....	19
Transmission.....	20
Engine - GM 4.3L.....	20
Engine - Cummins 4.5L and QSB 3.3L Diesel.....	21

This section is for the following models:

S6.0FT, S7.0FT (S135FT, S155FT) [D024, E024];  
H6.0FT, H7.0FT (H135FT, H155FT) [H006, J006]

## Lift Truck Lifting Capacity

Model	Weight
S6.0FT (S135FT)	6123 kg (13,500 lb)
S7.0FT (S155FT)	7030 kg (15,500 lb)
H6.0FT (H135FT)	6123 kg (13,500 lb)
H7.0FT (H155FT)	7030 kg (15,500 lb)

**NOTE:** Load center at 600 mm (24 in.).

## Counterweight Weights

Model	Weight
S6.0FT, S7.0FT (S135FT, S155FT)	2779 kg (6127 lb)
H6.0FT (H135FT)	2622 kg (5780 lb)
H7.0FT (H155FT)	3135 kg (6911 lb)

## Tire Sizes

Truck	Drive Tires	Steer Tires
S6.0FT, S7.0FT (S135FT, S155FT)	28 × 12 × 22	22 × 8 × 16
H6.0FT, H7.0FT (H135FT, H155FT)	8.25 × 15	8.25 × 15

## Capacities





*Table 1. S6.0FT, S7.0FT (S135FT, S155FT) (D024, E024) Lift Truck Models*

Item	Quantity	Specifications
<b>Fuel Capacity</b>		
Gas	65.8 liter (17.4 gal)	87 Octane
LPG	38.6 liter (10.2 gal) <b>Empty</b> 19.0 kg (41 lb) <b>Full</b> 38.2 kg (84.51 lb)	LPG-HD 5, HD 10
Diesel	65.8 liter (17.4 gal)	Diesel No. 2

*Table 1. S6.0FT, S7.0FT (S135FT, S155FT) (D024, E024) Lift Truck Models (Continued)*

Item	Quantity	Specifications
<b>Engine Oil</b>		
GM 4.3L	4.7 liter (5.0 qt)	-7°C (-20°F) and below SAE 5W-20  16°C (60 °F) and below SAE 5W-30  -18°C (0°F) and above SAE 10W-30 API SL ILSAC GF3 SAE J2362
Cummins 4.5L Diesel	13.0 liter (13.7 qt)	0°C (32°F) and below SAE 0W-30  -25 to 20°C (-13 to 68°F) SAE 5W-30  -20 to 20°C (-4 to 68°F) SAE 10W-30  -15°C (5°F) and above SAE 5W-40 or 15-40 API CH-4 or CI-4
Cummins QSB 3.3L Diesel	7.5 liter (8.0 qt)	0°C (32°F) and below SAE 0W-30  -25 to 20°C (-13 to 68°F) SAE 5W-30  -20 to 20°C (-4 to 68°F) SAE 10W-30  -15°C (5°F) and above SAE 5W-40 or 15-40 API CH-4 or CI-4

**Table 1. S6.0FT, S7.0FT (S135FT, S155FT) (D024, E024) Lift Truck Models (Continued)**

Item	Quantity	Specifications
<b>Cooling System</b>		
GM 4.3L	15.1 liter (15.9 qt)	 <b>CAUTION</b> <b>Additives may damage the cooling system. Before using additives, contact your local Hyster dealer.</b>  50% Water and 50% Ethylene Glycol, Boron-Free Antifreeze
Cummins 4.5L Diesel	13.5 liter (14.2 qt)	 <b>CAUTION</b> <b>Additives may damage the cooling system. Before using additives, contact your local Hyster dealer.</b>  50% Water and 50% Ethylene Glycol, Boron-Free Antifreeze
Cummins QSB 3.3L Diesel	10.4 liter (11.0 qt)	 <b>CAUTION</b> <b>Additives may damage the cooling system. Before using additives, contact your local Hyster dealer.</b>  50% Water and 50% Ethylene Glycol, Boron-Free Antifreeze
<b>Hydraulic Tank Oil Capacity</b>		
All Trucks	64 liter (68 qt) Initial Fill 60.5 liter (64 qt) Drain and Fill	 <b>CAUTION</b> <b>Additives may damage the hydraulic system. Before using additives, contact your local Hyster dealer.</b>  ISO VG-46 Hydraulic Oil –15°C (5°F) and above

(More Content includes: Brake system, Capacities, and specifications, Frame, Hydraulic, System, Industrial battery, Main control, Valve, Mast repair, Fasteners, Schematics diagrams, Steering axle, Steering system, Wire harness repair And more)

**[Click Here](#)**

**Get all the content  
after purchase**

**Thank you very  
much.**

*Table 1. S6.0FT, S7.0FT (S135FT, S155FT) (D024, E024) Lift Truck Models (Continued)*





Item	Quantity	Specifications
<b>Transmission Oil Capacity</b>		
Basic Powershift Transmission (2-Speed)	24 liter (25.4 qt)	John Deere JDM J20C
DuraMatch™ (3-Speed)	24 liter (25.2 qt)	John Deere JDM J20C
<b>Wet Brake Drive Axle Oil Capacities</b>		
Drive Axle Housing Arm Oil Right Chamber	8.8 liter (9.3 qt)	John Deere JDM J20C
Drive Axle Housing Arm Oil Left Chamber	8.8 liter (9.3 qt)	John Deere JDM J20C
Right Wheel Hub Oil	1.6 liter (1.7 qt)	John Deere JDM J20C
Left Wheel Hub Oil	1.6 liter (1.7 qt)	John Deere JDM J20C
<b>Brake Oil (Master Cylinder)</b>		
All Lift Truck Models	0.35 liter (0.74 pt)	 <b>WARNING</b> <b>DO NOT use DOT fluid; only use Dexron III oil from sealed container to prevent possible damage to the brake system. Failure to observe the above Warning could result in death or serious injury.</b>  Dexron III From Sealed Container
<b>Wet Brake Center Section Oil</b>		
All Lift Truck Models	4.2 liter (4.4 qt)	John Deere JDM J20C

**Table 2. H6.0FT, H7.0FT (H135FT, H155FT) (H006, J006) Lift Truck Models**

<b>Item</b>	<b>Quantity</b>	<b>Specifications</b>
<b>Fuel Capacity</b>		
Gas	74.8 liter (19.7 gal)	87 Octane
LPG	38.6 liter (10.2 gal) <b>Empty</b> 19.0 kg (41 lb) <b>Full</b> 38.2 kg (84.51 lb)	LPG-HD 5, HD 10
Diesel	74.8 liter (19.7 gal)	Diesel No. 2
<b>Engine Oil</b>		
GM 4.3L	4.7 liter (5.0 qt)	-7°C (-20°F) and below SAE 5W-20  16°C (60 °F) and below SAE 5W-30  -18°C (0°F) and above SAE 10W-30 API SL ILSAC GF3 SAE J2362
Cummins 4.5L Diesel	13.0 liter (13.7 qt)	0°C (32°F) and below SAE 0W-30  -25 to 20°C (-13 to 68°F) SAE 5W-30  -20 to 20°C (-4 to 68°F) SAE 10W-30  -15°C (5°F) and above SAE 5W-40 or 15-40 API CH-4 or CI-4
Cummins QSB 3.3L Diesel	7.5 liter (8.0 qt)	0°C (32°F) and below SAE 0W-30  -25 to 20°C (-13 to 68°F) SAE 5W-30  -20 to 20°C (-4 to 68°F) SAE 10W-30  -15°C (5°F) and above SAE 5W-40 or 15-40 API CH-4 or CI-4



Table 2. H6.0FT, H7.0FT (H135FT, H155FT) (H006, J006) Lift Truck Models (Continued)

Item	Quantity	Specifications
<b>Cooling System</b>		
GM 4.3L	15.1 liter (15.9 qt)	 <b>CAUTION</b> <b>Additives may damage the cooling system. Before using additives, contact your local Hyster dealer.</b>  50% Water and 50% Ethylene Glycol, Boron-Free Antifreeze
Cummins 4.5L Diesel	13.5 liter (14.2 qt)	 <b>CAUTION</b> <b>Additives may damage the cooling system. Before using additives, contact your local Hyster dealer.</b>  50% Water and 50% Ethylene Glycol, Boron-Free Antifreeze
Cummins QSB 3.3L Diesel	10.4 liter (11.0 qt)	 <b>CAUTION</b> <b>Additives may damage the cooling system. Before using additives, contact your local Hyster dealer.</b>  50% Water and 50% Ethylene Glycol, Boron-Free Antifreeze
<b>Hydraulic Tank Oil Capacity</b>		
All Trucks	75 liter (79 qt) Initial Fill 71.7 liter (75.7 qt) Drain and Fill	 <b>CAUTION</b> <b>Additives may damage the hydraulic system. Before using additives, contact your local Hyster dealer.</b>  ISO VG-46 Hydraulic Oil –15°C (5°F) and above
<b>Transmission Oil Level</b>		
Basic Powershift Transmission (2-Speed)	24 liter (25.4 qt)	John Deere JDM J20C
DuraMatch™ (3-Speed)	24 liter (25.4 qt)	John Deere JDM J20C

**Table 2. H6.0FT, H7.0FT (H135FT, H155FT) (H006, J006) Lift Truck Models (Continued)**

Item	Quantity	Specifications
<b>Wet Brake Drive Axle Oil Capacities</b>		
Drive Axle Housing Arm Oil Right Chamber	7.8 liter (8.25 qt)	John Deere JDM J20C
Drive Axle Housing Arm Oil Left Chamber	7.8 liter (8.25 qt)	John Deere JDM J20C
Right Wheel Hub Oil	N/A	N/A
Left Wheel Hub Oil	N/A	N/A
<b>Brake Oil (Master Cylinder)</b>		
All Lift Truck Models	0.35 liter (0.74 pt)	 <b>WARNING</b> <b>DO NOT use DOT fluid; only use Dexron III oil from sealed container to prevent possible damage to the brake system. Failure to observe the above Warning could result in death or serious injury.</b>  Dexron III From Sealed Container
<b>Wet Brake Center Section Oil</b>		
All Lift Truck Models	4.6 liter (4.9 qt)	John Deere JDM J20C

## Electrical System

**Table 3. S6.0FT, S7.0FT (S135FT, S155FT) (D024, E024) Lift Truck Models**

Item	GM 4.3L	Cummins 4.5L and QSB 3.3L Diesel
Battery	12-volt, negative ground	12-volt, negative ground
Spark Plugs	AC 41-993	N/A
Spark Plug Gap	1.5 mm (0.059 in.)	N/A
<b>Ignition Timing</b>		
Gas	Not Adjustable	N/A
LPG	Not Adjustable	N/A
Diesel	N/A	Not Adjustable

<b>GM 4.3L</b>		
<b>Alternator Output (14 Volts)</b>	<b>G and LPG</b>	<b>GS and LPS</b>
Idle	50 amps @ 750 rpm	38 amps @ 750 rpm
Governed Speed	65 amps @ 2400 rpm	45 amps @ 2400 rpm
<b>Cummins 4.5L (Diesel)</b>		
<b>Alternator Output (13.5 Volts)</b>	<b>D</b>	<b>DS</b>
Low Idle	54 amps @ 800 rpm	28 amps @ 800 rpm
Governed Speed	95 amps @ 2225 rpm	45 amps @ 2225 rpm
<b>Cummins QSB 3.3L (Diesel)</b>		
<b>Alternator Output (13.5 Volts)</b>	<b>D</b>	<b>DS</b>
Low Idle	30 amps @ 800 rpm	N/A
Governed Speed	95 amps @ 2230 rpm	N/A

**Table 4. H6.0FT, H7.0FT (H135FT, H155FT) (H006, J006) Lift Truck Models**

<b>Item</b>	<b>GM 4.3L</b>	<b>Cummins 4.5L</b>
Battery	12-volt, negative ground	12-volt, negative ground
Spark Plugs	AC 41-993	N/A
Spark Plug Gap	1.5 mm (0.059 in.)	N/A
Ignition Timing:		
Gas	Not Adjustable	N/A
LPG	Not Adjustable	N/A
Diesel	N/A	0.90 mm (0.035 in.)

<b>GM 4.3L</b>		
<b>Alternator Output (14 Volts)</b>	<b>G and LPG</b>	<b>GS and LPS</b>
Idle	50 amps @ 750 rpm	38 amps @ 750 rpm
Governed Speed	65 amps @ 2400 rpm	45 amps @ 2400 rpm
<b>Cummins 4.5L (Diesel)</b>		
<b>Alternator Output (13.5 Volts)</b>	<b>D</b>	<b>DS</b>
Low Idle	54 amps @ 800 rpm	32 amps @ 800 rpm
High Idle	95 amps @ 2225 rpm	45 amps @ 2225 rpm
<b>Cummins QSB 3.3L (Diesel)</b>		
<b>Alternator Output (13.5 Volts)</b>	<b>D</b>	<b>DS</b>
Low Idle	30 amps @ 800 rpm	20 amps @ 800 rpm
Governed Speed	95 amps @ 2230 rpm	45 amps @ 2230 rpm

### Transmission Oil Pressures

3-Speed Transmission All Pressures at 2000 rpm and Oil at 50 to 65°C (120 to 150°F)							
Port 1 Transmission Pump	Port 2	Port 3	Port 4	Port 5	Port 6	Port 7	Port 8
Low and High Pressure	Reverse Clutch (R1 and R2)	Forward Low Clutch (F1 and F2)	Forward High Clutch (F3)	Torque Converter	Lubrication	First Test Port (F1 and R1)	Second Test Port (F2, F3 and R2)
1793 to 2068* kPa (260 to 300 psi)	1793 to 2068 kPa (260 to 300 psi)	1793 to 2068 kPa (260 to 300 psi)	1793 to 2068 kPa (260 to 300 psi)	758 kPa (110 psi)	69 to 276 kPa (10 to 40 psi)	1793 to 2068 kPa (260 to 300 psi)	1793 to 2068 kPa (260 to 300 psi)

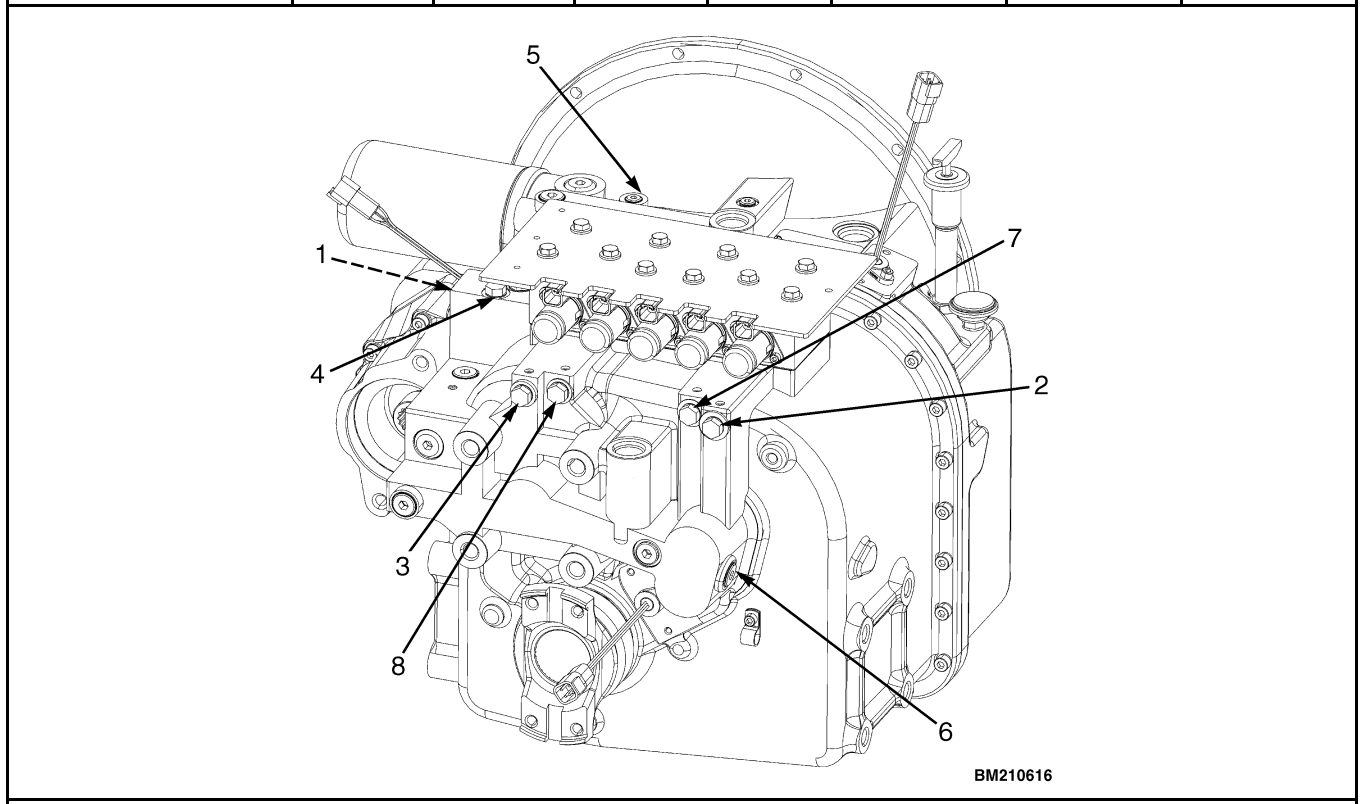

BM210616

\*Relief Pressure

2-Speed Transmission All Pressures at 2000 rpm and Oil at 50 to 65°C (120 to 150°F)							
Port 1 Transmission Pump	Port 2	Port 3	Port 4	Port 5	Port 6	Port 7	Port 8
Low and High Pressure	Reverse Clutch (R1 and R2)	Forward Low Clutch (F1)	Forward High Clutch (F2)	Torque Converter	Lubrication	First Test Port (F1 and R1)	Second Test Port (F2, and R2)
1793 to 2068* kPa (260 to 300 psi)	1793 to 2068 kPa (260 to 300 psi)	1793 to 2068 kPa (260 to 300 psi)	1793 to 2068 kPa (260 to 300 psi)	758 kPa (110 psi)	69 to 276 kPa (10 to 40 psi)	1793 to 2068 kPa (260 to 300 psi)	1793 to 2068 kPa (260 to 300 psi)

BM210616

\*Relief Pressure

### Hydraulic System Relief Pressures

Item	Specification
Oil Temperature	50 to 65°C (122 to 149°F)
Primary Relief Valve Pressure (High Idle)	22.1 ±0.48 MPa (3205 ± 70 psi)
Secondary Relief Valve Pressure (High Idle)	15.51 ±0.48 MPa (2250 ±70 psi)

## Steering System

**Table 5. S6.0FT, S7.0FT (S135FT, S155FT) (D024, E024) Lift Truck Models**

Item	Quantity	
Oil Temperature	50 to 65°C (122 to 149°F)	
Steering Relief Pressure at 800 rpms	12.4 $\pm$ 0.3 MPa (1798 $\pm$ 43.5 psi)	
Steering Cylinder Stroke (Each Side)	210.8 mm (8.3 in.)	
<b>Inside Steering Tire Angle</b>	80.3°	
Number of Turns to Lock	4.07	
<b>Turning Radius (<math>\pm</math>50 mm NO LOAD)</b>	<b>Outside</b>	<b>Inside</b>
All Trucks	2585	107

**Table 6. H6.0FT, H7.0FT (H135FT, H155FT) (H006, J006) Lift Truck Models**

Item	Quantity	
Oil Temperature	55 to 65°C (131 to 149°F)	
Steering Relief Pressure at 800 rpms	12.4 $\pm$ 0.3 MPa (1798 $\pm$ 43.5 psi)	
Steering Cylinder Stroke (Each Side)	224.0 mm (8.3 in.)	
<b>Inside Steering Tire Angle</b>	74.5°	
Number of Turns to Lock	3.50	
<b>Turning Radius (<math>\pm</math>76 mm NO LOAD)</b>	<b>Outside</b>	<b>Inside</b>
H6.0FT (H135FT)	3319	293
H7.0FT (H155FT)	3376	293

## Stall Speeds (in RPM $\pm$ 100 rpm)

**GM 4.3L GAS S6.0FT, S7.0FT,  
(S135FT,S155FT) (D024, E024)**

Transmission	New Engine	Broken-In Engine (30 hrs)
Basic Powershift	2160	2210
DuraMatch™	N/A*	N/A*
*DuraMatch™ transmission has torque limiting feature.		

**GM 4.3L LPG S6.0FT, S7.0FT,  
(S135FT,S155FT) (D024, E024)**

<b>Transmission</b>	<b>New Engine</b>	<b>Broken-In Engine (30 hrs)</b>
Basic Powershift	2070	2170
DuraMatch™	N/A*	N/A*
*DuraMatch™ transmission has torque limiting feature.		

**GM 4.3L GAS H6.0FT, H7.0FT (H135FT,  
H155FT) (H006, J006)**

<b>Transmission</b>	<b>New Engine</b>	<b>Broken-In Engine (30 hrs)</b>
Basic Powershift	2160	2210
DuraMatch™	N/A*	N/A*
*DuraMatch™ transmission has torque limiting feature.		

**GM 4.3L LPG H6.0FT, H7.0FT (H135FT,  
H155FT) (H006, J006)**

<b>Transmission</b>	<b>New Engine</b>	<b>Broken-In Engine (30 hrs)</b>
Basic Powershift	2070	2170
DuraMatch™	N/A*	N/A*
*DuraMatch™ transmission has torque limiting feature.		

**CUMMINS 4.5L DIESEL S6.0FT, S7.0FT,  
(S135FT,S155FT) (D024)**

<b>Transmission</b>	<b>New Engine</b>	<b>Broken-In Engine (30 hrs)</b>
Basic Powershift	1900	2050
DuraMatch™	N/A*	N/A*
*DuraMatch™ transmission has torque limiting feature.		

**CUMMINS QSB 3.3L DIESEL S6.0FT,  
S7.0FT, (S135FT,S155FT) (E024)**

<b>Transmission</b>	<b>New Engine</b>	<b>Broken-In Engine (30 hrs)</b>
Basic Powershift	1935	1950
DuraMatch™	N/A*	N/A*
*DuraMatch™ transmission has torque limiting feature.		

**CUMMINS 4.5L DIESEL H6.0FT, H7.0FT  
(H135FT, H155FT) (H006)**

<b>Transmission</b>	<b>New Engine</b>	<b>Broken-In Engine (30 hrs)</b>
Basic Powershift	1900	2050
DuraMatch™	N/A*	N/A*
*DuraMatch™ transmission has torque limiting feature.		

**CUMMINS QSB 3.3L DIESEL H6.0FT,  
H7.0FT (H135FT, H155FT) (J006)**

<b>Transmission</b>	<b>New Engine</b>	<b>Broken-In Engine (30 hrs)</b>
Basic Powershift	1935	1950
DuraMatch™	N/A*	N/A*
*DuraMatch™ transmission has torque limiting feature.		



## Mast Speeds

**NOTE:** Lift speed is measured in meters/sec (inch/sec) at governed engine RPM with full open valve and 65°C (149°F) oil temperature. Plus or minus 10% acceptable lifting or lowering.

Lowering speed is measured in meters/sec (inch/sec) with full open valve and 65°C (149°F) oil temperature.

**Table 7. Lift Truck Models S6.0FT(S135FT) (D024, E024)**

Engine	Mast	Lowering M/Sec (Inch/Sec)		Lifting M/Sec (Inch/Sec)	
		No Load	Rated Load	No Load	Rated Load
GM 4.3L	2-Stage LFL	0.53 (21.0)	0.58 (23.0)	0.54 (21.0)	0.53 (21.0)
	3-Stage FFL	0.41 (16.0)	0.53 (21.0)	0.52 (20.0)	0.51 (20.0)

**Table 8. Lift Truck Models S7.0FT (S155FT) (D024, E024)**

Engine	Mast	Lowering M/Sec (Inch/Sec)		Lifting M/Sec (Inch/Sec)	
		No Load	Rated Load	No Load	Rated Load
GM 4.3L	2-Stage LFL	0.53 (21.0)	0.58 (23.0)	0.54 (21.0)	0.53 (21.0)
	3-Stage FFL	0.41 (16.0)	0.55 (22.0)	0.52 (20.0)	0.51 (20.0)

**Table 9. Lift Truck Models S6.0FT(S135FT) (D024, E024)**

Engine	Mast	Lowering M/Sec (Inch/Sec)		Lifting M/Sec (Inch/Sec)	
		No Load	Rated Load	No Load	Rated Load
Cummins 4.5L and QSB 3.3L	2-Stage LFL	0.53 (21.0)	0.58 (23.0)	0.50 (20.0)	0.49 (19.0)
	3-Stage FFL	0.41 (16.0)	0.53 (21.0)	0.48 (19.0)	0.47 (19.0)

**Table 10. Lift Truck Models S7.0FT (S155FT) (D024, E024)**

Engine	Mast	Lowering M/Sec (Inch/Sec)		Lifting M/Sec (Inch/Sec)	
		No Load	Rated Load	No Load	Rated Load
Cummins 4.5L and QSB 3.3L	2-Stage LFL	0.53 (21.0)	0.58 (23.0)	0.46 (18.0)	0.45 (18.0)
	3-Stage FFL	0.41 (16.0)	0.55 (22.0)	0.44 (17.0)	0.43 (17.0)

**Table 11. Lift Truck Models H6.0FT (H135FT) (H006, J006)**

Engine	Mast	Lowering M/Sec (Inch/Sec)		Lifting M/Sec (Inch/Sec)	
		No Load	Rated Load	No Load	Rated Load
GM 4.3L	2-Stage LFL	0.53 (21.0)	0.58 (23.0)	0.54 (21.0)	0.53 (21.0)
	3-Stage FFL	0.41 (16.0)	0.53 (21.0)	0.52 (20.0)	0.51 (20.0)

**Table 12. Lift Truck Models H7.0FT (H155FT) (H006, J006)**

Engine	Mast	Lowering M/Sec (Inch/Sec)		Lifting M/Sec (Inch/Sec)	
		No Load	Rated Load	No Load	Rated Load
GM 4.3L	2-Stage LFL	0.53 (21.0)	0.58 (23.0)	0.54 (21.0)	0.53 (21.0)
	3-Stage FFL	0.41 (16.0)	0.55 (22.0)	0.52 (20.0)	0.51 (20.0)

**Table 13. Lift Truck Models H6.0FT (H135FT) (H006, J006)**

Engine	Mast	Lowering M/Sec (Inch/Sec)		Lifting M/Sec (Inch/Sec)	
		No Load	Rated Load	No Load	Rated Load
Cummins 4.5L	2-Stage LFL	0.53 (21.0)	0.58 (23.0)	0.50 (20.0)	0.49 (19.0)
	3-Stage FFL	0.41 (16.0)	0.53 (21.0)	0.48 (19.0)	0.47 (19.0)

**Table 14. Lift Truck Models H7.0FT (H155FT) (H006, J006)**

Engine	Mast	Lowering M/Sec (Inch/Sec)		Lifting M/Sec (Inch/Sec)	
		No Load	Rated Load	No Load	Rated Load
Cummins 4.5L	2-Stage LFL	0.53 (21.0)	0.58 (23.0)	0.46 (18.0)	0.45 (18.0)
	3-Stage FFL	0.41 (16.0)	0.55 (22.0)	0.44 (17.0)	0.43 (17.0)

## Tilt Angles

Lift truck should be on level ground and in unloaded condition.

**Table 15. S6.0FT, S7.0FT (S135FT, S155FT) (D024, E024) Lift Truck Models**

Mast Type	Forward	Tolerance	Back	Tolerance
2-Stage FFL, 3-Stage FFL, 3-Stage LFL	6°	+1°, -0.5°	6°	+0°, -0.5°
2-Stage LFL	6°	+1°, -0.5°	10°	+0°, -0.5°

**Table 16. H6.0FT, H7.0FT (H135FT, H155FT) (H006, J006) Lift Truck Models**

Mast Type	Forward	Tolerance	Back	Tolerance
2-Stage FFL, 3-Stage FFL, 3-Stage LFL	5°	+1°, -0.5°	6°	+0°, -0.5°
2-Stage LFL	5°	+1°, -0.5°	10°	+0°, -0.5°

## Front End Equipment - Mast Creep

### MAST CREEP

Measure with rated load at 2.5 m (8.0 ft) high and with the lift, tilt, and auxiliary control levers in neutral position.

**NOTE:** Mast should be 90° vertical prior to test.

**Table 17. S6.0FT, S7.0FT (S135FT, S155FT) (D024, E024) Lift Truck Models**

Hydraulic Oil Temperature		Maximum Vertical Creep at Carriage		Maximum Tilt Creep		
				Mast Angle	Cylinder Stroke	
°C	°F	mm/Min	in./Min	°/Min	mm/Min	in./Min
20	68	2.2	0.086	0.11	1.24	0.054
30	86	3.3	0.130	0.16	1.80	0.071
40	104	6.3	0.247	0.31	3.50	0.137
50	122	10.0	0.394	0.50	5.62	0.221
60	140	14.6	0.575	0.73	8.20	0.323

Table 18. H6.0FT, H7.0FT (H135FT, H155FT) (H006, J006) Lift Truck Models

Hydraulic Oil Temperature		Maximum Vertical Creep at Carriage		Maximum Tilt Creep		
				Mast Angle	Cylinder Stroke	
°C	°F	mm/Min	in./Min	°/Min	mm/Min	in./Min
20	68	2.2	0.086	0.11	1.30	0.051
30	86	3.3	0.130	0.16	1.90	0.075
40	104	6.3	0.247	0.31	3.67	0.145
50	122	10.0	0.394	0.50	5.92	0.233
60	140	14.6	0.575	0.73	8.65	0.341

## Engine Specifications

Item	GM 4.3L
No. of Cylinders	6
Firing Order	1-6-5-4-3-2
Bore	101.6 mm (3.9 in.)
Stroke	88.4 mm (3.48 in.)
Displacement	4.3 liter (262.4 in. <sup>3</sup> )
Horsepower (Gasoline)	100 @ 2400 rpm
Horsepower (LPG)	93 @ 2400 rpm
Engine Timing	Timing is controlled by the Electronic Control Module (ECM)
Compression Ratio	
Gas	9.4:1
LPG	9.4:1
Oil Pressure	207-380 ± 30 kPa (30-55 ± 4.4 psi) @ 2000 rpm 80°C (176°F)
Valve Clearance	
Intake	Not Adjustable
Exhaust	Not Adjustable
Idle Speed - Gas	750 ±25 rpm
Idle Speed - LPG	750 ±25 rpm
Governed Speed High Idle (No Load)	2400 ±25 rpm

Item	GM 4.3L
Thermostat Range	
STARTS TO OPEN	82 ±1.5°C (180 ±35°F)
FULL OPEN	128 ±1.5°C (260 ±35°F)
Cooling System Pressure	103 kPa (15 psi)

Item	Cummins 4.5L Diesel
No. of Cylinders	4
Firing Order	1-3-4-2
Bore and Stroke	102 mm × 138 mm (4.01 in. × 5.43 in.)
Displacement	4506 cc
Compression Ratio	17.6:1
Horsepower/rpm	78 @ 2050 rpm
Oil Pressure @ 80°C (176°F)	at low idle 69 kPa (10 psi) @ 800 rpm at high idle 207 kPa (30 psi) @ 2250 rpm
Valve Clearance	
Intake	0.254 mm (0.010 in.) (COLD)
Exhaust	0.508 mm (0.020 in.) (COLD)
Idle Speed (Cold Engine)	770 ±50 rpm
Idle Speed (Hot Engine)	800 ±50 rpm
Governed Speed High Idle (No Load)	2250 ±50 rpm
Thermostat Range	
STARTS TO OPEN	82°C (180°F)
FULL OPEN	95°C (203°F)
Cooling System Pressure	103 kPa (15 psi)

Item	Cummins QSB 3.3L Diesel
No. of Cylinders	4
Firing Order	1-3-4-2
Bore and Stroke	95 mm × 115 mm (3.74 in. × 4.53 in.)
Displacement	3261 cc
Compression Ratio	17.3:1
Horsepower/rpm (basic transmission)	80 @ 2200 rpm

Item	Cummins QSB 3.3L Diesel
Horsepower/rpm (Duramatch transmission)	99 @ 2200 rpm
Oil Pressure	49 kPa (7 psi)
Valve Clearance	
Intake	0.35 mm (0.014 in.)
Exhaust	0.50 mm (0.02 in.)
Idle Speed	800 ±25 rpm
Governed Speed High Idle (No Load)	2230 ±25 rpm
Thermostat Range	
START TO OPEN	82°C (180°F)
FULL OPEN	95°C (203°F)
Cooling System Pressure	103 kPa (15 psi)

## Torque Specifications

### FRAME

**Overhead Guard Mount Capscrews**  
66 N•m (49 lbf ft)

**Cowl-to-Overhead Guard Legs**  
66 N•m (49 lbf ft)

**Counterweight Capscrews**  
1020 N•m (750 lbf ft)

### MAST, LIFT TRUCK MODELS S6.0FT, S7.0FT (S135FT, S155FT) (D024, E024)

**Mast Mounting Capscrews**  
Mast to Drive Axle 320 N•m (236 lbf ft)  
Tilt/Cylinder Adjust 90 N•m (66 lbf ft)  
Pivot Pin Retainer 68 N•m (50 lbf ft)

### MAST, LIFT TRUCK MODELS H6.0FT, H7.0FT (H135FT, H155FT) (H006, J006)

**Mast Mounting Capscrews**  
Mast to Drive Axle 755 to 830 N•m (557 to 612 lbf ft)  
Tilt/Cylinder Adjust 90 to 99 N•m (66 to 73 lbf ft)  
Pivot Pin Retainer 68 N•m (50 lbf ft)

### STEERING SYSTEM

**Hub Nut (Slotted Nut), Lift Truck Models S6.0FT, S7.0FT (S135FT, S155FT) (D024, E024)**  
203 N•m (150 lbf ft) initial  
35 N•m (26 lbf in) final

**Hub Nut (Slotted Nut), Lift Truck Models H6.0FT, H7.0FT (H135FT, H155FT) (H006, J006)**  
203 N•m (150 lbf ft) initial  
34 N•m (25 lbf in) final

**Steering Axle Mounting Bolts and Nuts, Lift Truck Models S6.0FT, S7.0FT (S135FT, S155FT) (D024, E024)**  
250 to 275 N•m (184 to 203 lbf ft)

**Steering Axle Mounting Bolts and Nuts, Lift Truck Models H6.0FT, H7.0FT (H135FT, H155FT) (H006, J006)**  
270 N•m (199 lbf ft)

**Spindle Bearing Cap Capscrew, Lift Truck Models S6.0FT, S7.0FT (S135FT, S155FT) (D024, E024)**  
52 N•m (38 lbf ft)

**Spindle Bearing Cap Capscrew, Lift Truck Models H6.0FT, H7.0FT (H135FT, H155FT) (H006, J006)**  
47 N•m (35 lbf ft)

**Steering Cylinder Mounting Bolts**  
225 N•m (166 lbf ft)

## TRANSMISSION

**Transmission Mounting Bracket to Differential Housing Capscrew**  
225 to 255 N•m (166 to 188 lbf ft)

**Torque Converter Housing to Transmission Case Capscrews**  
38 N•m (28 lbf ft)

**Torque Converter Access Bolts**  
55 N•m (41 lbf ft)

**Drive Shaft to Output Yoke Capscrews**  
55 to 63 N•m (41 to 47 lbf ft)

**Control Valve Mounting Capscrews**  
20 to 25 N•m (15 to 18 lbf ft)

**Engine Mounting Bracket to Frame Bolts**  
320 N•m (236 lbf ft)

## ENGINE - GM 4.3L

**Alternator Pulley**  
61 N•m (45 lbf ft)

**Balance Shaft Gear Capscrew**  
20 N•m (177 lbf in) Plus 35 Degrees

**Balance Shaft Retainer Capscrews**  
12 N•m (106 lbf in)

**Camshaft Retainer Screws**  
12 N•m (106 lbf in)

**Camshaft Sprocket Capscrews**  
28 N•m (21 lbf ft)

**Camshaft Sprocket Nut**  
25 N•m (18 lbf ft)

**Chain Control Block for Hydraulic Pump Drive**  
19 N•m (168 lbf in) with Adhesive Sealant

**Connecting Rod Cap**  
27 N•m (240 lbf in)

After this step, tighten nuts an additional 70 degrees.

**Coolant Pump to Engine Block**  
41 N•m (30 lbf ft)

**Cooling Fan to Pulley**  
24 N•m (212 lbf in)

**Cylinder Head**  
See the section **GM Engines, 4.3 Liter V-6 600 SRM 1251** for torque value and tightening sequence to use.

**Distributor Mount Capscrew**  
25 N•m (18 lbf ft)

**Exhaust Manifold**  
15 N•m (133 lbf in) - first step  
30 N•m (22 lbf ft) - second step

**Flywheel**  
100 N•m (74 lbf ft)

**Flywheel Housing**  
48 N•m (35 lbf ft)

**Inlet Manifold to Cylinder Head**  
3 N•m (27 lbf in) - first step  
12 N•m (106 lbf ft) - second step  
15 N•m (133 lbf in) - third step (final)

**Main Bearing Cap**  
105 N•m (77 lbf ft)

**Motor Mount to Engine**  
31 N•m (23 lbf ft)

**Oil Pump Cover**  
12 N•m (106 lbf in)

**Oil Pump to Crankcase**  
90 N•m (66 lbf ft)

**Oil Pressure Switch**  
27 N•m (20 lbf ft)

**Oil Screen Support to Crankcase**  
50 N•m (37 lbf ft)

**Oil Pan to Crankcase**  
Capscrews 25 N•m (18 lbf ft)  
Nuts 25 N•m (18 lbf ft)

**Rear Oil Seal Retainer Screws and Nut**  
15 N•m (133 lbf in)

**Rocker Arm Cover**  
12 N•m (106 lbf in)

**Rocker Arm Nuts**  
25 N•m (18 lbf ft)

**Rocker Arm Studs**

47 N•m (35 lbf ft)

**Rocker Arm Bolts**

30 N•m (22 lbf ft)

**Thermostat Housing**

25 N•m (18 lbf ft)

**Timing Cover**

12 N•m (106 lbf in)

**Valve Lifter Retainer Capscrews**

16 N•m (142 lbf in)

**Vibration Damper**

95 N•m (70 lbf ft)

**ENGINE - CUMMINS 4.5L AND QSB 3.3L  
DIESEL**

For torque instructions for the Cummins 4.5L and QSB 3.3L diesel engine, contact your local **Hyster** dealer or see **Hyster Hypass Online**.





