

CAPACITIES AND SPECIFICATIONS

H8.00-12.00XM (H170-280HD) [F007, G007];
H13.00-16.00XM (H300-360HD) [E019, F019];
H10.00-12.00XM-12EC (H360HD-EC) [E019, F019]

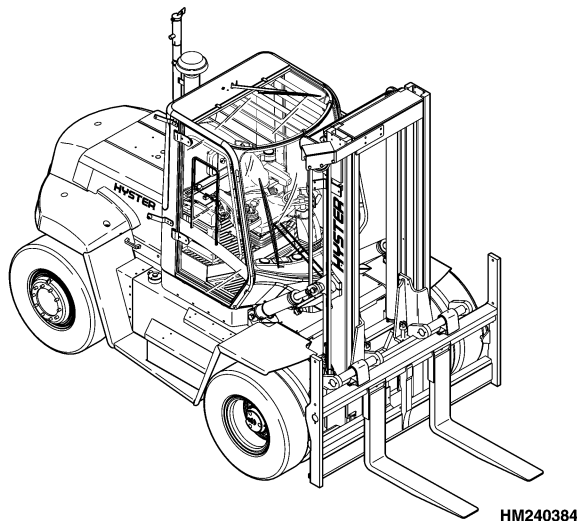

HM240384

HYSTER

TABLE OF CONTENTS

Lift Truck Weights 1

Capacities 1

Engine Specifications..... 2

 Perkins Diesel..... 2

 Cummins Diesel/LPG..... 3

Hydraulic System..... 4

Electrical System 5

Tire Sizes 5

Mast Speeds 5

 Perkins Diesel..... 5

 Cummins Diesel/LPG..... 6

Torque Specifications, Cummins Diesel..... 7

 Lubrication System 7

Torque Specifications, Perkins Diesel..... 7

 Engine 7

 Cylinder Head Assembly..... 7

 Piston and Connecting Rod Assemblies 7

 Crankshaft Assembly..... 7

 Timing Case and Drive Assembly 8

 Turbocharger 8

 Lubrication System 8

 Fuel System 8

 Cooling System 8

 Flywheel and Housing 8

 Aspiration System 9

 Electrical Equipment 9

 Auxiliary Equipment..... 9

Torque Specifications - Perkins, Tier 2 9

 Cylinder Head Assembly..... 9

 Piston and Connecting Rod Assemblies 9

 Crankshaft Assembly..... 9

 Timing Case and Drive Assembly..... 9

 Turbocharger..... 10

 Lubrication System 10

 Fuel System 10

 Cooling System 10

 Flywheel..... 10

 Auxiliary Equipment..... 10

Torque Specifications, General..... 11

 Transmission..... 11

 Driveline and Axle..... 11

 Differential..... 11

 Brakes - Wet..... 11

 Brakes - Dry..... 11

 Steering 11

 Hydraulic System 12

 Mast..... 12

 Carriage..... 12

 Tilt Cylinders 12

 Frame 12

 Wiper Arms, Front..... 12

TABLE OF CONTENTS (Continued)

Hyster T-50 Transmission Pressures (Powershift and Automatic).....	13
TE-10 Transmission Specifications.....	14
Electrical.....	14
Hydraulic Cooler Lines.....	14
Torque Specifications for Lubricated or Plated Screw Threads.....	15

This section is for the following models:

H8.00-12.00XM (H170-280HD) [F007, G007];
H13.00-16.00XM (H300-360HD) [E019, F019];
H10.00-12.00XM-12EC (H360HD-EC) [E019, F019]

Lift Truck Weights

Unit	kg	lb
H170HD	11,735	25,872
H8.00XM (H190HD)	11,928	26,296
H9.00XM (H210HD)	12,508	27,572
H10.00XM (H230HD)	14,144	31,178
H250HD	14,343	31,621
H12.00XM (H280HD)	15,787	34,800
H13.00XM (H300HD)	16,669	36,753
H14.00XM (H330HD)	17,826	39,303
H16.00XM (H360HD)	18,710	41,253
H10.00XM-12EC	21,198	46,734
H12.00XM-12EC (H360HD-EC)	24,695	54,443
H8.00-12.00XM (H170-280HD) models: 5335 mm (210 in.) mast, 2350 mm (92.5 in.) standard carriage, 65 [70] × 200 × 1220 mm (2.6 [2.76] × 8 × 48 in.) forks.		
H13.00-16.00XM (H300-360HD) models: 5310 mm (209 in.) mast, 2502 mm (98.5 in.) standard carriage, 90 × 200 × 1375 mm (3.5 × 8 × 54 in.) forks.		
H10.00XM-12EC models: 6806 mm (268 in.) lift height mast and attachment.		
H12.00XM-12EC (H360HD-EC) models: 9796 mm (386 in.) lift height mast and attachment.		

Capacities

Item	Quantity
Engine Oil, Perkins Diesel 1006-60, With Oil Filter	13.2 liter (13.9 qt)
Engine Oil, Perkins 1006-60T, With Oil Filter	14.2 liter (15 qt)
Engine Oil, Perkins 1106C-E60 TA Tier 2, With Oil Filter	14.2 liter (15 qt)
Engine Oil, Cummins QSB5.9-30 and B LPG Plus, With Oil Filter	16.3 liter (17.2 qt)
Cooling System, Perkins 1006-60	26 liter (27.5 qt)
Cooling System, Perkins 1006-60T	31 liter (32.8 qt)
Cooling System, Perkins 1106C-E60 TA Tier 2	25.5 liter (27 qt)
Cooling System, Cummins	25.5 liter (27 qt)
Hydraulic Tank (FULL mark)	
H8.00-12.00XM (H170-280HD)	109 liter (28.8 gal)
H13.00-16.00XM (H300-360HD); H10.00-12.00XM-12EC (H360HD-EC)	109 liter (28.8 gal)

(More Content includes: Brake system, Capacities, and specifications, Frame, Hydraulic, System, Industrial battery, Main control, Valve, Mast repair, Fasteners, Schematics diagrams, Steering axle, Steering system, Wire harness repair And more)

[Click Here](#)

**Get all the content
after purchase**

**Thank you very
much.**

Item	Quantity
Hydraulic System (Total Capacity)	
H8.00-12.00XM (H170-280HD)	139 liter (36.7 gal)
H13.00-16.00XM (H300-360HD); H10.00-12.00XM-12EC (H360HD-EC)	139 liter (36.7 gal)
Transmission	16.5 liter (17.4 qt)
Drive Axle and Differential	
Dry Brake System	
H8.00-12.00XM (H170-280HD)	19 liter (20 qt)
H13.00-16.00XM (H300-360HD); H10.00-12.00XM-12EC (H360HD-EC)	21 liter (21.1 qt)
Wet Brake System	
H8.00-12.00XM (H170-280HD)	19 liter (20 qt)
H13.00-16.00XM (H300-360HD); H10.00-12.00XM-12EC (H360HD-EC)	21 liter (21.1 qt)
Planetary Gears	
H8.00-12.00XM (H170-280HD)	2.8 liter (3.0 qt) each
H13.00-16.00XM (H300-360HD); H10.00-12.00XM-12EC (H360HD-EC)	2.4 liter (2.5 qt) each
Fuel Tank (Diesel Engines)	128 liter (33.8 gal)
LPG Tank	LPG HD-10 77 liter (20.3 gal)

Engine Specifications

PERKINS DIESEL

Item	Specification
Type	Perkins 1006-60, 1006-60T and 1106C-E60 TA, Tier 2
Numbers of Cylinders	6
Firing Order	1-5-3-6-2-4
Bore	100 mm (3.937 in.)
Stroke	127 mm (5.000 in.)
Displacement	6 liter (366 in. ³)
Compression Ratio	17.25:1
Oil Pressure (Minimum, at 2200 rpm and normal operating temperature)	280 kPa (40 psi)
Governed Speed (Full power and normal operating temperature)	
1006-60	2200 rpm with load, 2310 ±50 no load
1006-60T	2300 rpm with load, 2415 ±50 no load
Governed Speed (To high idle)	
1106C-E60 TA, Tier 2	2415 ±10

Item	Specification
Idle Speed	
1006-60	725 to 775 rpm
1006-60T	725 to 775 rpm
1106C-E60 TA, Tier 2	740 to 760 rpm
Stall Speed (Broken-in Engine)	
1006-60	1925 ±50 rpm
1006-60T/1106C-E60 TA, Tier 2	2095 ±50 rpm
Fuel Injection Timing	23° BTDC (Static)
Thermostat	
Begin to open	80 to 84°C (176 to 183°F)
Fully open	96°C (205°F)
Valve Clearance (Cold)	
Intake	0.20 mm (0.008 in.)
Exhaust	0.45 mm (0.018 in.)

CUMMINS DIESEL/LPG

Item	Specification	
Type	Cummins B LPG Plus	Cummins QSB5.9-30
Number of Cylinders	6	6
Firing Order	1-5-3-6-2-4	1-5-3-6-2-4
Bore	102 mm (4.02 in.)	102 mm (4.02 in.)
Stroke	120 mm (4.62 in.)	120 mm (4.62 in.)
Displacement	5.88 liter (359 in. ³)	5.88 liter (359 in. ³)
Compression Ratio	9.25:1	18:1
Oil Pressure (Minimum, at 2500 rpm and normal operating temperature)	345 kPa (50 psi)	345 kPa (50 psi)
Oil Pressure (At low idle)	69 kPa (10 psi)	69 kPa (10 psi)
Governed Speed (Full power at Normal Operating Temperature)		
H8.00-16.00XM, H10.00-12.00XM-12EC	2500 rpm with load 2600 ±50 no load	2300 rpm with load 2450±30 no load
H170-360HD, H360HD-EC	2500 rpm with load 2600 ±50 no load	2500 rpm with load 2600±50 no load
Idle Speed	850 rpm±2%	725 ±2%
Stall Speed (Broken-in Engine)	1950 to 2100 rpm	1950 to 2100 rpm

Item	Specification	
Thermostat		
Begin to open	83°C (181°F)	83°C (181°F)
Fully open	91°C (196°F)	91°C (196°F)
Valve Clearance (Cold)		
Intake	0.305 mm (0.012 in.)	0.25 mm (0.01 in.)
Exhaust	0.61 mm (0.024 in.)	0.51 mm (0.02 in.)

Hydraulic System

Item	Quantity
Perkins Hydraulic Pump Capacity @ 2300 rpm for turbo, 2200 rpm for nonturbo	
Main Section @ 21 MPa (3045 psi)	
1006-60T/1106C-E60 TA	192 liter/min (51 gal/min)
1006-60	160 liter/min (42.3 gal/min)
Steering/Aux Section @ 19.3 MPa (2800 psi)	
1006-60T/1106C-E60 TA	93 liter/min (24.6 gal/min)
1006-60	78 liter/min (20.6 gal/min)
Cummins Diesel Hydraulic Pump Capacity @ 2300 rpm	
Main Section @ 21 MPa (3045 psi)	192 liter/min (51 gal/min)
Steering/Aux Section @ 19.3 MPa (2800 psi)	93 liter/min (24.6 gal/min)
Cummins LPG Hydraulic Pump Capacity @ 2500 rpm	
Main Section @ 21 MPa (3045 psi)	183 liter/min (48.3 gal/min)
Steering/Aux Section @ 19.3 MPa (2800 psi)	89 liter/min (23.5 gal/min)
Relief Pressures *	
Main Control Valve	
Lift Circuit	21.0 MPa (3045 psi)
Tilt and Auxiliary Circuits	19.3 MPa (2800 psi)
Steering Circuit	16.5 MPa (2400 psi)
ECH Functions	14.0 MPa (2030 psi)
*Oil temperature 60°C (140°F)	

Electrical System

All Models 24 Volt, Negative Ground	
Alternator Output at 24°C (75°F)	
All Engines	21 amps at 750 rpm
	76 amps at 2200 rpm

Tire Sizes

Model	Tire Size
H8.00-9.00XM (H170-210HD)	9.00 × 20-12 ply
H10.00-12.00XM (H230-280HD)	10.00 × 20-14 ply
H13.00XM (H300HD)	11.00 × 20-14 ply
H13.00-16.00XM (H300-360HD)	12.00 × 20-16 ply
H10.00-12.00XM-12EC (H360HD-EC)	12.00 × 20-16 ply
Tire inflation pressure: 690 kPa (100 psi)	

Mast Speeds

PERKINS DIESEL

Unit	Lifting				Lifting				Lifting				Lowering			
	1006.60				1006.60T				1106C-E60 TA				1006.60, 1006.60T and 1106C-E60 TA			
	No Load		Rated Load		No Load		Rated Load		No Load		Rated Load		No Load		Rated Load	
	m/sec	ft/min	m/sec	ft/min	m/sec	ft/min	m/sec	ft/min	m/sec	ft/min	m/sec	ft/min	m/sec	ft/min	m/sec	ft/min
H170HD	0.63	124	0.41	80	0.73	143	0.48	96	0.73	143	0.48	96	0.48	95	0.50	98
H8.00XM (H190HD)	0.63	124	0.41	80	0.73	143	0.48	96	0.73	143	0.48	96	0.48	95	0.50	98
H9.00XM (H210HD)	0.63	124	0.41	80	0.73	143	0.48	96	0.73	143	0.48	96	0.48	95	0.50	98
H10.00XM (H230HD)	0.53	104	0.36	70	0.56	110	0.38	74	0.53	104	0.34	67	0.46	91	0.49	97
H250HD	0.53	104	0.36	70	0.56	110	0.38	74	0.53	104	0.34	67	0.46	91	0.49	97
H12.00XM (H280HD)	0.53	104	0.36	70	0.56	110	0.38	74	0.53	104	0.34	67	0.46	91	0.49	97
H13.00XM (H300HD)	-	-	-	-	0.46	91	0.30	59	0.44	87	0.29	57	0.44	87	0.48	95

Unit	Lifting				Lifting				Lifting				Lowering			
	1006.60				1006.60T				1106C-E60 TA				1006.60, 1006.60T and 1106C-E60 TA			
	No Load		Rated Load		No Load		Rated Load		No Load		Rated Load		No Load		Rated Load	
	m/sec	ft/min	m/sec	ft/min	m/sec	ft/min	m/sec	ft/min	m/sec	ft/min	m/sec	ft/min	m/sec	ft/min	m/sec	ft/min
H14.00XM (H330HD)	-	-	-	-	0.46	91	0.30	59	0.44	87	0.29	57	0.44	87	0.48	95
H16.00XM (H360HD)	-	-	-	-	0.46	91	0.30	59	0.44	87	0.29	57	0.44	87	0.48	95
H10.00XM-12EC	-	-	-	-	0.63	124	0.43	85	0.63	124	0.43	85	0.45	89	0.47	93
H12.00XM-12EC (H360HD-EC)	-	-	-	-	0.63	124	0.43	85	0.63	124	0.43	85	0.45	89	0.47	93

CUMMINS DIESEL/LPG

Unit	Lifting				Lifting				Lowering			
	B LPG Plus				QSB5.9-30				B LPG Plus/QSB5.9-30			
	NOTE: Cummins LPG Plus engine not available for H10.00-12.00XM-12EC (H360HD-EC) models.											
	No Load		Rated Load		No Load		Rated Load		No Load		Rated Load	
	m/sec	ft/min	m/sec	ft/min	m/sec	ft/min	m/sec	ft/min	m/sec	ft/min	m/sec	ft/min
H170HD	0.69	136	0.37	73	0.73	143	0.48	95	0.48	95	0.50	98
H8.00XM (H190HD)	0.69	136	0.37	73	0.73	143	0.48	95	0.48	95	0.50	98
H9.00XM (H210HD)	0.69	136	0.37	73	0.73	143	0.48	95	0.48	95	0.50	98
H10.00XM (H230HD)	0.50	98	0.26	51	0.53	104	0.46	91	0.46	91	0.49	97
H250HD	0.50	98	0.26	51	0.53	104	0.46	91	0.46	91	0.49	97
H12.00XM (H280HD)	0.50	98	0.26	51	0.53	104	0.46	91	0.46	91	0.49	97
H13.00XM (H300HD)	0.41	81	0.22	43	0.44	87	0.29	57	0.44	87	0.48	95
H14.00XM (H330HD)	0.41	81	0.22	43	0.44	87	0.29	57	0.44	87	0.48	95
H16.00XM (H360HD)	0.41	81	0.22	43	0.44	87	0.29	57	0.44	87	0.48	95

Unit	Lifting				Lifting				Lowering			
	B LPG Plus				QSB5.9-30				B LPG Plus/QSB5.9-30			
	NOTE: Cummins LPG Plus engine not available for H10.00-12.00XM-12EC (H360HD-EC) models.											
	No Load		Rated Load		No Load		Rated Load		No Load		Rated Load	
	m/ sec	ft/ min	m/ sec	ft/ min	m/ sec	ft/ min	m/ sec	ft/ min	m/ sec	ft/ min	m/ sec	ft/ min
H10.00XM-12EC	N/A	N/A	N/A	N/A	0.63	124	0.43	84	0.45	89	0.47	93
H12.00XM-12EC (H360HD-EC)	N/A	N/A	N/A	N/A	0.63	124	0.43	84	0.45	89	0.47	93

Torque Specifications, Cummins Diesel

LUBRICATION SYSTEM

Plug, Oil Sump, Steel Oil Pan
80 N•m (59 lbf ft)

Plug, Oil Sump, Aluminum Oil Pan
60 N•m (44 lbf ft)

All other Torque Specifications are found in Cummins Engine Manual. Contact Cummins Engine for any torque specifications not listed for this engine.

Torque Specifications, Perkins Diesel

ENGINE

Capscrews, Engine Lift Brackets
44 N•m (32 lbf ft)

Cylinder Head Assembly

Piston and Connecting Rod Assemblies

Capscrews, Cylinder Head Special Procedure
(See the section **Perkins Diesel Engines, 1004-42 (AR), 1006-60 (YG), 1006-60T (YH) 600 SRM 705**)

Nuts, Connecting Rods
125 N•m (92 lbf ft)

Fasteners, Rocker Arm Brackets
Aluminum 40 N•m (30 lbf ft)
Cast Iron 75 N•m (55 lbf ft)

Capscrews, Connecting Rods
155 N•m (114 lbf ft)

Cap Nuts, Valve Cover
20 N•m (15 lbf ft)

Banjo Bolts, Piston Cooling Jets
27 N•m (20 lbf ft)

Capscrews, Inlet Manifold to Cylinder Head
44 N•m (32 lbf ft)

Crankshaft Assembly

Nuts (cadmium plated) Exhaust Manifold to Cylinder Head
44 N•m (32 lbf ft)

Capscrews, Main Bearings
265 N•m (195 lbf ft)

Capscrews, Crankshaft Pulley
115 N•m (85 lbf ft)

Capscrews, Viscous Damper to Crankshaft Pulley

75 N•m (55 lbf ft)

Capscrews, Damper to Crankshaft Pulley

35 N•m (26 lbf ft)

Capscrews, Rear Oil Seal Housing to Engine Block

22 N•m (16 lbf ft)

Capscrews, Bridge Piece to Cylinder Block

16 N•m (12 lbf ft)

Capscrews, Rear Oil Seal Housing to Bridge Piece

13 N•m (10 lbf ft)

Torx-head screw, Rear Oil Seal Housing to Engine Block

18 N•m (13 lbf ft)

Timing Case and Drive Assembly**Capscrews, Timing Case to Engine Block**

M8 22 N•m (16 lbf ft)

M10 44 N•m (32 lbf ft)

Capscrews, Hub of Idler Gear

44 N•m (32 lbf ft)

Capscrew, Camshaft Gear

95 N•m (70 lbf ft)

Capscrews, Timing Case Cover to Timing Case

22 N•m (16 lbf ft)

Nuts, Timing Case Cover to Timing Case

22 N•m (16 lbf ft)

Turbocharger**Nuts, Turbocharger to Manifold**

44 N•m (32 lbf ft)

Lubrication System**Plug, Oil Sump**

34 N•m (25 lbf ft)

Capscrews, Oil Pump to Front Bearing Cap

22 N•m (16 lbf ft)

Capscrews, Cover for Oil Pump

28 N•m (21 lbf ft)

Fasteners, Oil Sump

22 N•m (16 lbf ft)

Fuel System**Nuts, High-pressure Fuel Lines**

22 N•m (16 lbf ft)

Bolt Leak-off Connection

9 N•m (7 lbf ft)

Capscrews, Fuel Lift Pump

22 N•m (16 lbf ft)

Nut for Fuel Injector Body

40 N•m (30 lbf ft)

Capscrews for Gear of Fuel Injection Pump

28 N•m (21 lbf ft)

Special (Torx-head) Screws for the Gear of the Fuel Injection Pump

22 N•m (16 lbf ft)

Nuts for Flange of Fuel Injection Pump

22 N•m (16 lbf ft)

Locking Screw of Lucas DP 200 Fuel Injection Pump

10 N•m (7 lbf ft)

Cooling System**Capscrews for Fan Drive Housing to Timing Case**

44 N•m (32 lbf ft)

Capscrews, Fan Drive Pulley to Hub M8

22 N•m (16 lbf ft)

Capscrews, Fan Drive Pulley to Hub M10

44 N•m (32 lbf ft)

Capscrews, Fan

22 N•m (16 lbf ft)

Flywheel and Housing**Capscrews, Flywheel to Crankshaft**

105 N•m (77 lbf ft)

Capscrews, Cast Iron Flywheel Housing to Cylinder Block:

Head Stamped 8.8 (M10) 44 N•m (32 lbf ft)

Head Stamped 8.8 (M12) 75 N•m (55 lbf ft)

Head Stamped 10.9 (M10) 63 N•m (46 lbf ft)

Head Stamped 10.9 (M12) 115 N•m (85 lbf ft)

Capscrews, Aluminum Flywheel Housing to Cylinder Block

70 N•m (52 lbf ft)

Capscrews, Flywheel Housing to Cylinder Block (Paper Joint)
70 N•m (52 lbf ft)

Aspiration System

Nuts, Turbocharger to Manifold
44 N•m (32 lbf ft)

Electrical Equipment

Nut, Alternator Pulley:
Lucas CAV AC5RA and AC4RS 55 N•m (41 lbf ft)
Thin nut A127 and Motorola pulley 22 mm A/F 60 N•m (44 lbf ft)
Thick nut A127 and Motorola pulley 22 mm A/F 80 N•m (59 lbf ft)

Fueled Start Aid to Induction Manifold
31 N•m (23 lbf ft)

Nut/screw, Starter Motor
31 N•m (23 lbf ft)

Auxiliary Equipment

Nut, Air Compressor Drive Gear to Compressor Drive Shaft
120 N•m (89 lbf ft)

Nut, (30mm A/F) Air Compressor Gears
130 N•m (96 lbf ft)

Capscrew, Bracket to Idler Hub
60 N•m (44 lbf ft)

Capscrew, Bracket to Timing Case
35 N•m (26 lbf ft)

Torque Specifications - Perkins, Tier 2

CYLINDER HEAD ASSEMBLY

Capscrews, Cylinder Head 1/2 UNF (Special Procedure, see the section **Perkins Tier 2 Diesel Engines, 1100 (VK)** 600 SRM 1068, Install, Cylinder Head Assembly Repair.)

Fasteners, Rocker Arm Brackets
Cast Iron M12 75 N•m (55 lbf ft)

Cap Nuts, Valve Cover
M6 9 N•m (7 lbf ft)

Capscrews, Inlet Manifold to Cylinder Head
M8 22 N•m (16 lbf ft)

Nuts (Non-plated), Exhaust Manifold to Cylinder Head
M8 25 N•m (18 lbf ft)

Capscrews, Engine Lift Brackets
M10 44 N•m (33 lbf ft)

PISTON AND CONNECTING ROD ASSEMBLIES

Nuts, Connecting Rods
1/2 UNF 125 N•m (92 lbf ft)

Banjo Bolts, Piston Cooling Jets
3/8 UNF 27 N•m (20 lbf ft)

CRANKSHAFT ASSEMBLY

Capscrews, Main Bearings
5/8 UNF 265 N•m (195 lbf ft)

Capscrews, Crankshaft Pulley
7/16 UNF 115 N•m (85 lbf ft)

Capscrews, Engine Front Mounting Bracket to Cylinder Block
M16 190 N•m (140 lbf ft)

Capscrews, Viscous Damper to Crankshaft Pulley
M12 75 N•m (55 lbf ft)

Capscrews, Damper to Crankshaft Pulley
M8 35 N•m (26 lbf ft)

Capscrews, Rear Oil Seal Housing to Engine Block
M8 22 N•m (16 lbf ft)

Capscrews, Bridge Piece to Cylinder Block
M6 16 N•m (12 lbf ft)

Capscrews, Rear Oil Seal Housing to Bridge Piece
M6 13 N•m (10 lbf ft)

TIMING CASE AND DRIVE ASSEMBLY

Capscrews, Timing Case to Engine Block
M8 22 N•m (16 lbf ft)

Capscrews, Hub of Idler Gear

M10 44 N•m (32 lbf ft)

Capscrew, Camshaft Gear

M12 95 N•m (70 lbf ft)

Capscrews, Timing Case Cover to Timing Case

M8 22 N•m (16 lbf ft)

Nuts, Timing Case Cover to Timing Case

M8 22 N•m (16 lbf ft)

TURBOCHARGER**Nuts, Turbocharger to Manifold**

M10 44 N•m (32 lbf ft)

LUBRICATION SYSTEM**Plug, Oil Sump**

3/4 UNF 34 N•m (25 lbf ft)

Capscrews, Oil Pump to Front Bearing Cap

M8 22 N•m (16 lbf ft)

Capscrews, Cover for Oil Pump

M8 28 N•m (21 lbf ft)

Fasteners, Oil Sump

M8 22 N•m (16 lbf ft)

FUEL SYSTEM**Nuts, High to Pressure Fuel Lines**

M12 27.5 N•m (20 lbf ft)

Bolt, Leak-Off Connection

M8 9 N•m (7 lbf ft)

Capscrews, Fuel Lift Pump

M8 22 N•m (16 lbf ft)

Nut for Fuel Injector Body

40 N•m (30 lbf ft)

Capscrews for Gear of Fuel Injection Pump

M10 28 N•m (20 lbf ft)

Special (Torx) Screws for Gear of Fuel Injection Pump

M10 22 N•m (16 lbf ft)

Nuts for Flange of Fuel Injection Pump

M8 22 N•m (16 lbf ft)

COOLING SYSTEM**Capscrews for Fan Drive Housing to Timing Case**

M10 44 N•m (32 lbf ft)

Capscrews, Thermostat Housing to Cylinder Head

M8 22 N•m (16 lbf ft)

Capscrews, Fan Drive Pulley to Hub

M10 44 N•m (32 lbf ft)

Capscrews, Fan

M8 22 N•m (16 lbf ft)

FLYWHEEL**Capscrews, Flywheel to Crankshaft**

1/2 UNF 107 N•m (79 lbf ft)

AUXILIARY EQUIPMENT**Nut, Air Compressor Drive Gear to Compressor Drive Shaft**

5/8 UNF 120 N•m (88 lbf ft)

Capscrew, Bracket to Compressor

M10 22 N•m (16 lbf ft)

Capscrew, Bracket to Cylinder Block

M8 44 N•m (32 lbf ft)

Torque Specifications, General

TRANSMISSION

Nuts, Mount Bolts for Isolator

155 N•m (114 lbf ft)

Capscrews, Mount Bracket to Transmission

270 N•m (200 lbf ft)

Capscrews, Transmission to Flywheel Housing

Perkins 31 N•m (23 lbf ft)

Cummins 25 N•m (19 lbf ft)

Capscrews, Drive Plate to Flywheel

36 N•m (26.5 lbf ft)

Nut, Output Yoke

270 to 339 N•m (200 to 250 lbf ft)

Capscrews, Drive Plate to Torque Convertor

50 N•m (37 lbf ft)

Oil Screen Assembly

14 to 20 N•m (10 to 15 lbf ft)

Oil Filter

27 to 34 N•m (20 to 25 lbf ft)

See the sections **Three-Speed Powershift Transmission, Repairs (Hyster Model T-50)** 1300 SRM 931 and **Transmission** 1300 SRM 1082 for other torque values.

DRIVELINE AND AXLE

Capscrews, Universal Yoke

50 N•m (37 lbf ft)

Bolts, Axle to Frame

920 N•m (679 lbf ft)

Nuts, Wheel (Front and Rear)

640 to 680 N•m (472 to 502 lbf ft)

DIFFERENTIAL

See the section **Differential** 1400 SRM 46.

BRAKES - WET

See the sections **Planetary Drive Axle, (Wet System)** 1400 SRM 944 and **Wet Brake System** 1800 SRM 951.

BRAKES - DRY

Air Fittings in Air Chambers

34 N•m (25 lbf ft)

Nuts Air Chamber Ring Clamps

H8.00-12.00XM (H170-280HD) 27 to

34 N•m (20 to 25 lbf ft)

H13.00-16.00XM (H300-360HD) 34 to

47 N•m (25 to 35 lbf ft)

Jam Nut, Clevis

47 to 68 N•m (35 to 50 lbf ft)

Lock Nuts, Air Chamber Studs

135 to 156 N•m (100 to 115 lbf ft)

Capscrew, Brake Anchor Pin

14 N•m (10 lbf ft)

Capscrew, Spider See the section **Dry Brake System** 1800 SRM 937.

STEERING

Nut, Steering Wheel

68 N•m (50 lbf ft)

Capscrews, Steer Cylinder Mount

435 N•m (321 lbf ft)

Capscrews, Bearing Cap

75 N•m (55 lbf ft)

Nut, Wheel Bearing

Initial 203 N•m (150 lbf ft)

Final 34 N•m (25 lbf ft)

Note: Torque lock nut to Initial torque while rotating wheel hub. Back off lock nut until wheel hub turns freely with no end play. (Torque at this point should be less than 27 N•m (20 lbf ft)). Retorque to Final torque and lock in place at first alignment position which occurs at or above final torque spec.

Nuts, Wheel (Front and Rear)

640 to 680 N•m (472 to 502 lbf ft)

Capscrews, Steer Axle Mount

270 N•m (199 lbf ft)

HYDRAULIC SYSTEM**Nuts, Hydraulic Pump Assembly**

271 N•m (200 lbf ft)

Capscrews, High-pressure Hose Flange

71 N•m (52 lbf ft)

Capscrews, Suction Hose Flange

110 N•m (81 lbf ft)

Nuts, Control Valve Assembly

7/16 in. 65 N•m (48 lbf ft)

1/2 in. 100 N•m (74 lbf ft)

Jam Nut, Relief Valve Adjustment

55 to 67 N•m (41 to 49 lbf ft)

Capscrews, Pump Mount

110 N•m (81 lbf ft)

MAST**Capscrews, Pivot Pin**

435 N•m (321 lbf ft)

Capscrew, Bearing Block

9 N•m (7 lbf ft)

Capscrews, Bearing Block Bracket

44 N•m (32 lbf ft)

Nuts, Wear Plate

53 N•m (39 lbf ft)

Retainer, Lift CylinderH8.00-9.00XM (H170-210HD) 400 to 475 N•m
(295 to 350 lbf ft)H10.00-12.00XM (H230-280HD) 475 to
550 N•m (350 to 406 lbf ft)H13.00-16.00XM (H300-360HD) 550 to
625 N•m (406 to 461 lbf ft)**CARRIAGE****Capscrew, Bearing Block**

9 N•m (7 lbf ft)

Capscrews, Bearing Block Bracket

44 N•m (32 lbf ft)

Nut, Sideshift Cylinder Rod

675 N•m (498 lbf ft)

TILT CYLINDERS**Nut, Cylinder Rod**

H8.00-12.00XM (H170-280HD) 950 to

983 N•m (701 to 725 lbf ft)

H13.00-16.00XM (H300-360HD) 1105 to

1140 N•m (815 to 841 lbf ft)

Retainer

H8.00-12.00XM (H170-280HD) 542 to

610 N•m (400 to 450 lbf ft)

H13.00-16.00XM (H300-360HD) 610 to

675 N•m (450 to 498 lbf ft)

Lock Nut, Rod End

66 N•m (49 lbf ft)

Capscrew, Pin Anchor

165 N•m (122 lbf ft)

FRAME**Capscrew, Rear Counterweight, Lubricated**

1900 N•m (1401 lbf ft)

Nuts, Fender Counterweight, Lubricated

320 N•m (236 lbf ft)

Capscrews, Frame Counterweight, Lubricated

640 N•m (472 lbf ft)

WIPER ARMS, FRONT**Capscrews, Bracket to Cab**

20 to 25 N•m (14.7 to 18.4 lbf ft)

Capscrews, Arm to Bracket

22 to 27 N•m (16.2 to 19.9 lbf ft)

Capscrews, Blade to Arm

8 to 10 N•m (6 to 7.4 lbf ft)

Capscrew, Arm Set

35 to 45 N•m (25.8 to 33.2 lbf ft)

Hyster T-50 Transmission Pressures (Powershift and Automatic)

A	System Pressure	1100 to 1310 kPa (160 to 190 psi)	
H	Torque Converter Supply (Port H is on the right-hand side of the transmission pump)	827 to 1034 kPa (120 to 150 psi)	
G	Lubrication System Pressure	55 to 103 kPa (8 to 15 psi)	
C	Reverse Clutch Pressure*	1100 to 1310 kPa (160 to 190 psi)**	
E	Forward Clutch Pressure*	1100 to 1310 kPa (160 to 190 psi)**	
F	1st Speed Clutch Pressure	1100 to 1310 kPa (160 to 190 psi)**	
D	2nd Speed Clutch Pressure	1100 to 1310 kPa (160 to 190 psi)**	
B	3rd Speed Clutch Pressure	1100 to 1310 kPa (160 to 190 psi)**	
J	Forward Pilot Pressure	1100 to 1310 kPa (160 to 190 psi)	

*Inching pressures 0 to 310 ±34 kPa (0 to 45 ±5 psi)

Modulator pressure increases 414 to 758 kPa (60 to 110 psi) in 1.2 to 1.6 seconds.

**The difference in clutch pressures for all clutches cannot be greater than 70 kPa (10 psi).

HM240401

TE-10 Transmission Specifications

ELECTRICAL

Electronic-controlled modulation solenoids

VFS 2nd - VFS 1st/3rd - VFS Fwd - VFS Rev

Coil resistance - $4.35 \pm 0.35\Omega$ at 25°C (77°F)

On/Off solenoids

Total neutral and selector solenoids

Coil resistance - 12V - $28 \pm 2\Omega$ at 20°C (68°F)

Coil resistance - 24V - $28 \pm 2\Omega$ at 20°C (68°F)

Speed sensor

Type - Magneto resistive sensor.

Sensing distance - 0 to 1.8 mm (0 to 0.07 in.)

Sensor signal - Generates a square current with a fixed amplitude changing between 7 and 14 mA.

Table 1. Temperature Sensor (In Speed Sensor) Resistance vs Temperature

Ambient Temperature	Resistance Ω
-55°C (-67°F)	980
-50°C (-58°F)	1030
-40°C (-40°F)	1135
-30°C (-22°F)	1247
-20°C (-4°F)	1367
-10°C (14°F)	1496
0°C (32°F)	1630
10°C (50°F)	1772
20°C (68°F)	1922
25°C (77°F)	2000

Table 1. Temperature Sensor (In Speed Sensor) Resistance vs Temperature (Continued)

Ambient Temperature	Resistance Ω
30°C (86°F)	2080
40°C (104°F)	2245
50°C (122°F)	2417
60°C (140°F)	2597
70°C (158°F)	2785
80°C (176°F)	2980
90°C (194°F)	3182
100°C (212°F)	3392
110°C (230°F)	3607
120°C (248°F)	3817
125°C (257°F)	3915
130°C (266°F)	4008
140°C (284°F)	4166
150°C (302°F)	4280

HYDRAULIC COOLER LINES

There is a minimum 19 mm (0.75 in.) internal diameter for lines and fittings. They must be suitable for operation from ambient temperature to 120°C (248°F) continuous operating temperature. They must withstand 30 bar (435 psi) continuous pressure and 45 bar (652 psi) intermittent surges. Conform SAE J1019 and SAE J517, 100RI.

TORQUE SPECIFICATIONS FOR LUBRICATED OR PLATED SCREW THREADS

Table 2. Grade 5

Nom. Size	Fine Thread	Coarse Thread
0.2500	12.2 to 14.9 N•m (9 to 11 lbf ft)	10.8 to 13.6 N•m (8 to 10 lbf ft)
0.3125	21.7 to 27.1 N•m (16 to 20 lbf ft)	16.3 to 21.7 N•m (12 to 16 lbf ft)
0.3750	35.2 to 39.3 N•m (26 to 29 lbf ft)	31.2 to 33.9 N•m (23 to 25 lbf ft)
0.4375	55.6 to 61 N•m (41 to 45 lbf ft)	50.2 to 55.6 N•m (37 to 41 lbf ft)
0.5000	86.8 to 94.9 N•m (64 to 70 lbf ft)	77.3 to 85.4 N•m (57 to 63 lbf ft)
0.5625	123.4 to 135.6 N•m (91 to 100 lbf ft)	111.2 to 122 N•m (82 to 90 lbf ft)
0.6250	173.5 to 191.1 N•m (128 to 141 lbf ft)	153.2 to 168.1 N•m (113 to 124 lbf ft)
0.7500	302.3 to 332.1 N•m (223 to 245 lbf ft)	271.1 to 298.2 N•m (200 to 220 lbf ft)

Table 3. Grade 8

Nom. Size	Fine Thread	Coarse Thread
0.2500	14.9 to 17.6 N•m (11 to 13 lbf ft)	12.2 to 14.9 N•m (9 to 11 lbf ft)
0.3125	38 to 43.4 N•m (28 to 32 lbf ft)	35.2 to 40.7 N•m (26 to 30 lbf ft)
0.3750	50.2 to 55.6 N•m (37 to 41 lbf ft)	44.7 to 48.8 N•m (33 to 36 lbf ft)
0.4375	78.6 to 86.8 N•m (58 to 64 lbf ft)	70.5 to 77.3 N•m (52 to 57 lbf ft)
0.5000	122 to 134.2 N•m (90 to 99 lbf ft)	108.4 to 119.3 N•m (80 to 88 lbf ft)
0.5625	173.5 to 191.1 N•m (128 to 141 lbf ft)	155.9 to 172.2 N•m (115 to 127 lbf ft)
0.6250	244 to 268.4 N•m (180 to 198 lbf ft)	215.5 to 237.2 N•m (159 to 175 lbf ft)
0.7500	427 to 470.4 N•m (315 to 347 lbf ft)	382.3 to 420.2 N•m (282 to 310 lbf ft)

Table 4. Grades 8.8, 10.9, and 12.9

Nom. Size	Grade 8.8	Grade 10.9	Grade 12.9
	Coarse Thread	Coarse Thread	Coarse Thread
M5	5 to 6 N•m (3.7 to 4.4 lbf ft)	7 to 8 N•m (5.2 to 5.9 lbf ft)	8 to 10 N•m (5.9 to 7.4 lbf ft)
M6	8 to 10 N•m (5.9 to 7.4 lbf ft)	12 to 15 N•m (8.9 to 11.1 lbf ft)	13 to 16 N•m (9.6 to 11.8 lbf ft)
M8	20 to 25 N•m (14.8 to 18.4 lbf ft)	30 to 35 N•m (22.1 to 25.8 lbf ft)	35 to 40 N•m (25.8 to 29.5 lbf ft)
M10	40 to 50 N•m (29.5 to 36.9 lbf ft)	60 to 65 N•m (44.3 to 47.9 lbf ft)	65 to 75 N•m (47.9 to 55.3 lbf ft)

Table 4. Grades 8.8, 10.9, and 12.9 (Continued)

Nom. Size	Grade 8.8	Grade 10.9	Grade 12.9
	Coarse Thread	Coarse Thread	Coarse Thread
M12	68 to 75 N•m (50.2 to 55.3 lbf ft)	100 to 110 N•m (73.8 to 81.1 lbf ft)	115 to 130 N•m (84.8 to 95.9 lbf ft)
M14	110 to 125 N•m (81.1 to 92.2 lbf ft)	150 to 175 N•m (110.6 to 129.1 lbf ft)	180 to 210 N•m (132.8 to 154.9 lbf ft)
M16	170 to 190 N•m (125.4 to 140.1 lbf ft)	240 to 275 N•m (177 to 202.8 lbf ft)	280 to 320 N•m (206.5 to 236 lbf ft)
M20	320 to 360 N•m (236 to 265.5 lbf ft)	450 to 500 N•m (331.9 to 368.8 lbf ft)	525 to 600 N•m (387.2 to 442.5 lbf ft)
M24	570 to 650 N•m (420.4 to 479.4 lbf ft)	800 to 900 N•m (590.1 to 663.8 lbf ft)	900 to 1050 N•m (663.8 to 774.4 lbf ft)
M30	1150 to 1300 N•m (848.2 to 958.8 lbf ft)	1600 to 1800 N•m (1180.1 to 1327.6 lbf ft)	1850 to 2100 N•m (1364.5 to 1548.9 lbf ft)
M36	2000 to 2250 N•m (1475.1 to 1659.5 lbf ft)	2749 to 3149 N•m (2027.6 to 2322.6 lbf ft)	3249 to 3699 N•m (2396.3 to 2728.2 lbf ft)

Table 5. O-ring Port Plug Torque Chart

Thread Size NPTF	Torque
1/16 × 27	7 to 9 N•m (5 to 7 lbf ft)
1/8 × 27	9 to 14 N•m (7 to 10 lbf ft)
1/4 × 18	20 to 27 N•m (15 to 20 lbf ft)
3/8 × 18	34 to 41 N•m (25 to 30 lbf ft)
1/2 × 14	41 to 47 N•m (30 to 35 lbf ft)
3/4 × 10 or 14	54 to 61 N•m (40 to 45 lbf ft)
1 × 11 1/2	68 to 75 N•m (50 to 55 lbf ft)
1 1/4 × 11 1/2	81 to 88 N•m (60 to 65 lbf ft)
M10 × 1	8 to 10 N•m (6 to 7 lbf ft)
M14 × 1.5	10 to 12 N•m (7 to 9 lbf ft)
M18 × 1.5	34 to 41 N•m (25 to 30 lbf ft)

Table 5. O-ring Port Plug Torque Chart (Continued)

Thread Size NPTF	Torque
M22 × 1.5	48 to 60 N•m (35 to 44 lbf ft)
M33 × 2	112 to 140 N•m (83 to 103 lbf ft)

Table 6. Pipe Plug Torque Chart

Nom. Size	Plugs (Permanent Plugs)
	Torque
M18 × 1.5 6H	34 to 41 N•m (25 to 30 lbf ft)
M26 × 1.5 6H	61 to 68 N•m (45 to 50 lbf ft)

