

PARTS MANUAL

ELECTRIC

**J1.60-2.00XMT
(G160)**

CUSTOMER EDITION

HYSTER

SECTIONS

1	FRAME
2	ELECTRICAL SYSTEM
3	DRIVE UNIT
4	STEERING SYSTEM
5	BRAKE/ACCELERATOR SYSTEM
6	HYDRAULIC SYSTEM
7	MAST-TWO STAGE LIMITED FREE-LIFT
8	MAST-THREE STAGE FULL FREE-LIFT
9	MAST-TWO STAGE FULL FREE-LIFT
10	OPTIONS
11	NUMERICAL INDEX

This Parts Manual is divided into 11 major sections which are listed above. Quick reference to these sections can be made by placing the right thumb on the tab of the desired section, bending the book back and thumbing the pages to the corresponding tab.

1

FRAME

SECTION 1
FRAME

DESCRIPTION	PAGE
BATTERY COMPARTMENT	1-2
COUNTERWEIGHT	1-6
DECAL AND PLATE LOCATION	1-14
FORK ASSEMBLY	
D/B 10/2001⇒	1-18
⇒D/B 10/2001	1-17
LOAD BACKREST EXTENSION.....	1-16
NON-SUSPENSION SEAT	1-10
OVERHEAD GUARD.....	1-8
SUSPENSION SEAT	1-12

BATTERY COMPARTMENT (Figure 1-1)

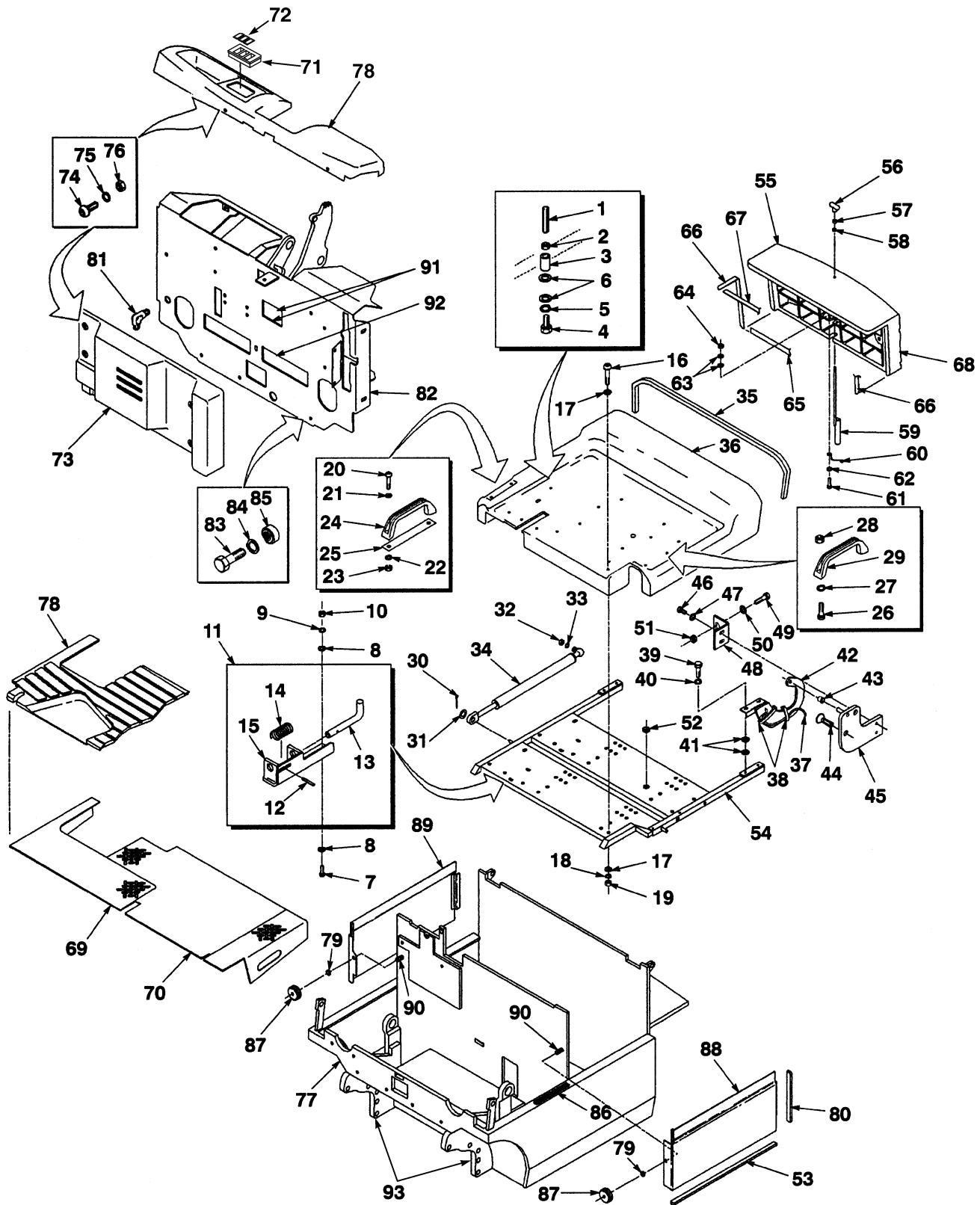

BP120037

BATTERY COMPARTMENT**KEY:****A: 1495 mm Wheel Base (J1.80-2.00XMT)****B: 1385 mm Wheel Base (J1.60XMT)**

ITEM	PART NO.	DESCRIPTION	QTY	
			A	B
1	2309936	Stud	1	1
2	15026	Nut	1	1
3	2309977	Bushing.....	1	1
4	16634	Capscrew.....	1	1
5	15156	Lockwasher.....	1	1
6	15176	Washer	2	2
7	136749	Capscrew.....	2	2
8	320157	Washer	4	4
9	292681	Lockwasher.....	2	2
10	239503	Nut	2	2
11	2311028	Latch.....	1	1
12	19981	Pin	1	1
13	2305068	Pin	1	1
14	2307799	Spring	1	1
15	2305209	Guide	1	1
16	296166	Capscrew.....	5	5
17	320158	Washer	10	10
18	292681	Lockwasher.....	5	5
19	292654	Nut	5	5
20	292502	Capscrew.....	2	2
21	320156	Washer	2	2
22	292680	Lockwasher.....	2	2
23	136687	Nut	4	4
24	362030	Handle	1	1
25	2310622	Plate	1	1
26	293796	Capscrew.....	2	2
27	292680	Lockwasher.....	2	2
28	136687	Nut	2	2
29	362030	Handle	1	1
30	15223	Cotter Pin.....	2	2
31	320158	Washer	2	2
32	239503	Nut	2	2
33	292681	Lockwasher.....	2	2
34	c 1467476	Gas Spring.....	2	2
34	b 2031138	Gas Spring.....	2	2
35	261164	Seal	1	1
36	2013604	Battery Cover.....	1	..
36	2032486	Battery Cover.....	..	1
37	1463490	Wire Harness.....	1	1
38	137852	Strap Clamp.....	3	2
39	136749	Capscrew.....	4	4
40	292681	Lockwasher.....	4	4
41	320158	Washer	8	8
42	2013627	Hinge (LH)	1	1
42	2013626	Hinge (RH).....	1	1
43	2310972	Bearing	2	2

BATTERY COMPARTMENT

ITEM	PART NO.	DESCRIPTION	QTY	
			A	B
44	296252	Bolt	4	4
45	2013630	Pivot (LH).....	1	1
45	2013629	Pivot (RH).....	1	1
46	267851	Bolt (Hex Head).....	4	4
47	292681	Lockwasher.....	4	4
48	2013631	Spacer	2	2
49	2311598	Screw.....	2	2
50	15176	Washer	2	2
51	269200	Nut	2	2
52	143413	Grommet.....	1	1
53	261158	Foam Tape.....	AR	AR
54	2032006	Frame	1	..
54	2032007	Frame	1
55	2013642	Cover Assembly.....	1	1
56	2014534	Knob	1	1
57	15086	Nut	1	1
58	216735	Grommet.....	1	1
59	1452304	Tow Pin	1	1
60	2013847	Retainer	1	1
61	293603	Capscrew.....	2	2
62	292680	Lockwasher.....	2	2
63	296417	Lockwasher.....	6	6
64	136687	Nut	2	2
65	283259	Foam Tape.....	AR	AR
66	2013646	Seal Strip	2	2
67	2013644	Seal Strip	1	1
68	2013576	Cover	1	1
69	2033783	Floorplate (RH).....	1	1
69	a 878803	Floorplate (RH).....	1	1
70	2033076	Floorplate (LH).....	1	1
71	376947	Bezel.....	1	1
72	376949	Cover	3	3
73	2307691	Cover (Front).....	1	1
74	302047	Screw.....	4	4
75	320156	Washer	6	6
76	136687	Nut	6	6
77	1462453	Frame J1.60XMT).....	..	1
77	1462454	Frame (J1.80XMT).....	1	..
77	1462455	Frame (J2.00XMT).....	1	..
78	1462623	Cowl Cover Assembly.....	1	1
78	1462622	Cowl Cover (Front)	1	1
79	279737	Grommet.....	2	2
80	261156	Foam Tape.....	AR	AR
81	16458	Fitting.....	1	1
82	1462649	Cowl.....	1	1
83	292515	Capscrew.....	2	2
84	320159	Washer	2	2
85	2307638	Fastener.....	2	2
86	2309317	Anti-Slip Pad (Anti-Slip)	1	1
87	2014993	Nut	2	2
88	2015005	Side Plate (LH)	1	..

BATTERY COMPARTMENT

ITEM	PART NO.	DESCRIPTION	QTY	
			A	B
88	2032103	Side Plate (LH)	1
89	2014981	Side Plate (RH).....	1	..
89	2014980	Side Plate (RH).....	..	1
90	2302961	Stud	2	2
90	136687	Nut	2	2
90	320156	Washer	2	2
91	2034115	Trim	2	2
92	2034116	Trim	1	1
93	2034899	Bracket (Tilt Cylinder)	2	2
94	2033110	Floor Mat	1	1

FOOTNOTES:

- a** Used with Motor Cooling Fan Option
- b** ⇒ D/B 06/2000
- c** D/B 06/2000 ⇒

COUNTERWEIGHT (Figure 1-2)

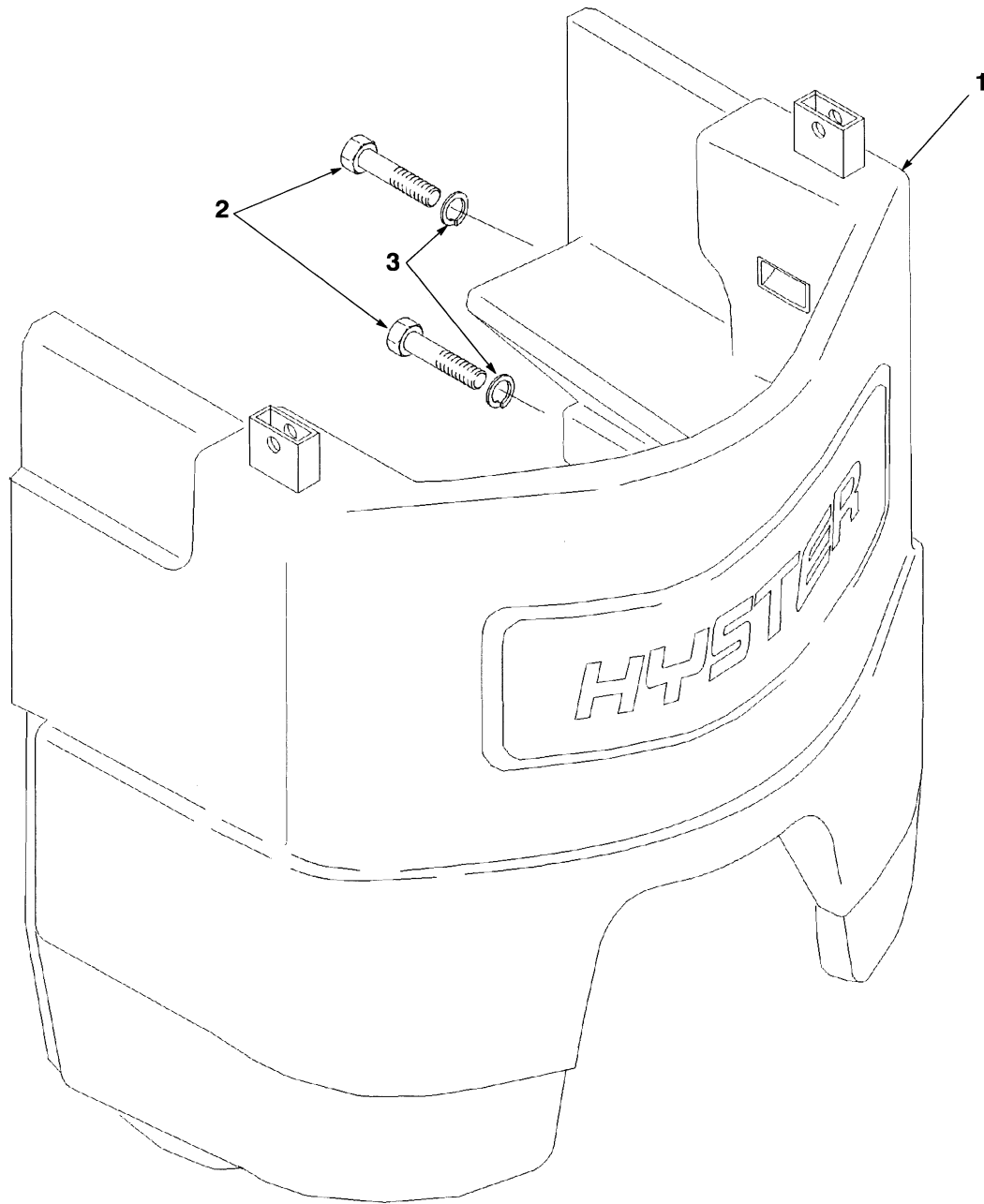

HP120521

ITEM	PART NO.	DESCRIPTION	QTY
1	2013485	Counterweight	1
2	293706	Capscrew	4
3	296431	Washer	4

OVERHEAD GUARD (Figure 1-3)

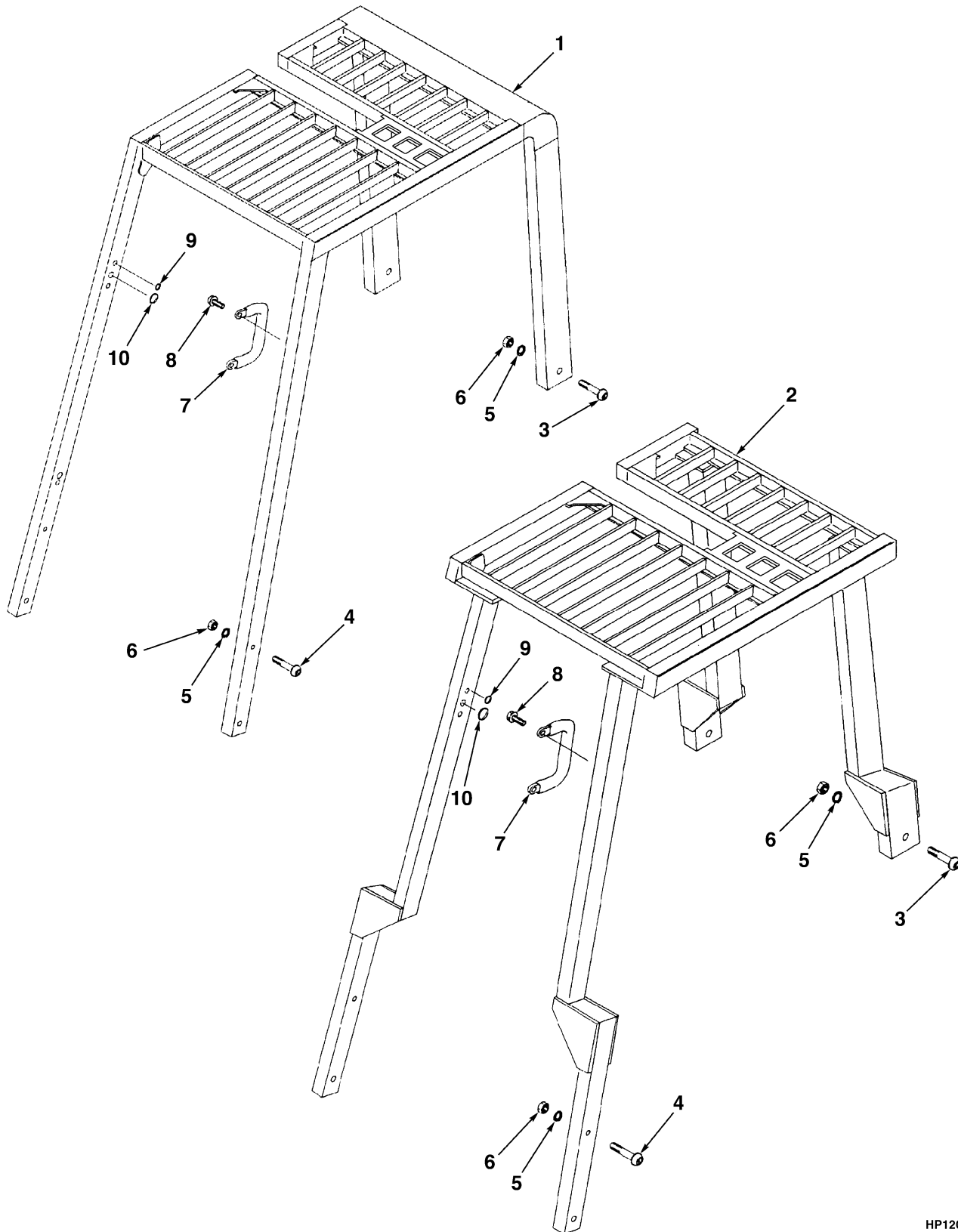

HP120522

OVERHEAD GUARD**KEY:****A: Standard****B: Drive-in Rack Option**

ITEM	PART NO.	DESCRIPTION	QTY	
			A	B
1	a 1493931	Overhead Guard (1385 Wheel Base) (2060MM OAH)	1	..
1	b 1493930	Overhead Guard (1495 Wheel Base) (2060MM OAH)	1	..
2	b 1469940	Overhead Guard (1495 Wheel Base) (Raised) (2060MM OAH)	1
2	a 1469941	Overhead Guard (1385 Wheel Base) (Raised) (2060MM OAH)	1
3	1353533	Capscrew.....	5	5
4	1343990	Capscrew.....	1	1
5	320162	Washer	12	12
6	216877	Nut	6	6
7	1343647	Handle	1	1
8	316678	Screw.....	2	2
9	1363916	Plug	13	15
10	1363917	Plug	7	7

FOOTNOTES:**a** J1.60XMT**b** J1.80-2.00XMT

NON-SUSPENSION SEAT (Figure 1-4)

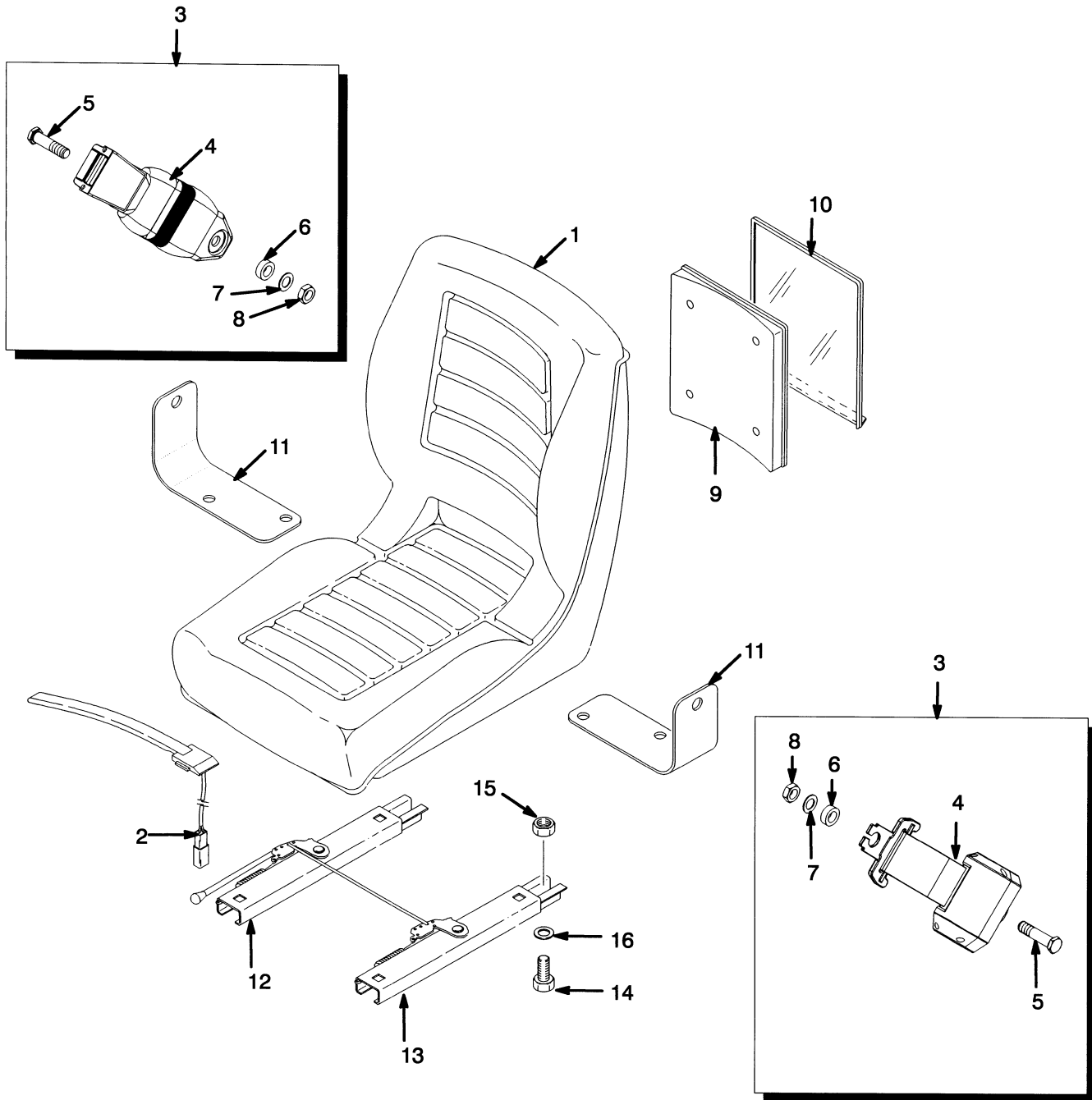

BP000036

NON-SUSPENSION SEAT

ITEM	PART NO.	DESCRIPTION	QTY
	1460231	Non-Suspension Seat.....	1
1	364911	Seat.....	1
2	2037311	Switch Assembly	1
3	1461081	Seat Belt Kit.....	1
4	Seat Belt	1
5	Screw	2
6	Washer.....	2
7	Washer.....	2
8	Nut	2
9	335988	Base (Information Case)	1
10	335991	Cover (Information Case).....	1
11	1470175	Bracket	1
12	1470176	Seat Rail.....	1
13	1470177	Seat Rail.....	1
14	16836	Capscrew.....	4
15	145639	Nut	4
16	15175	Washer	4

SUSPENSION SEAT (Figure 1-5)

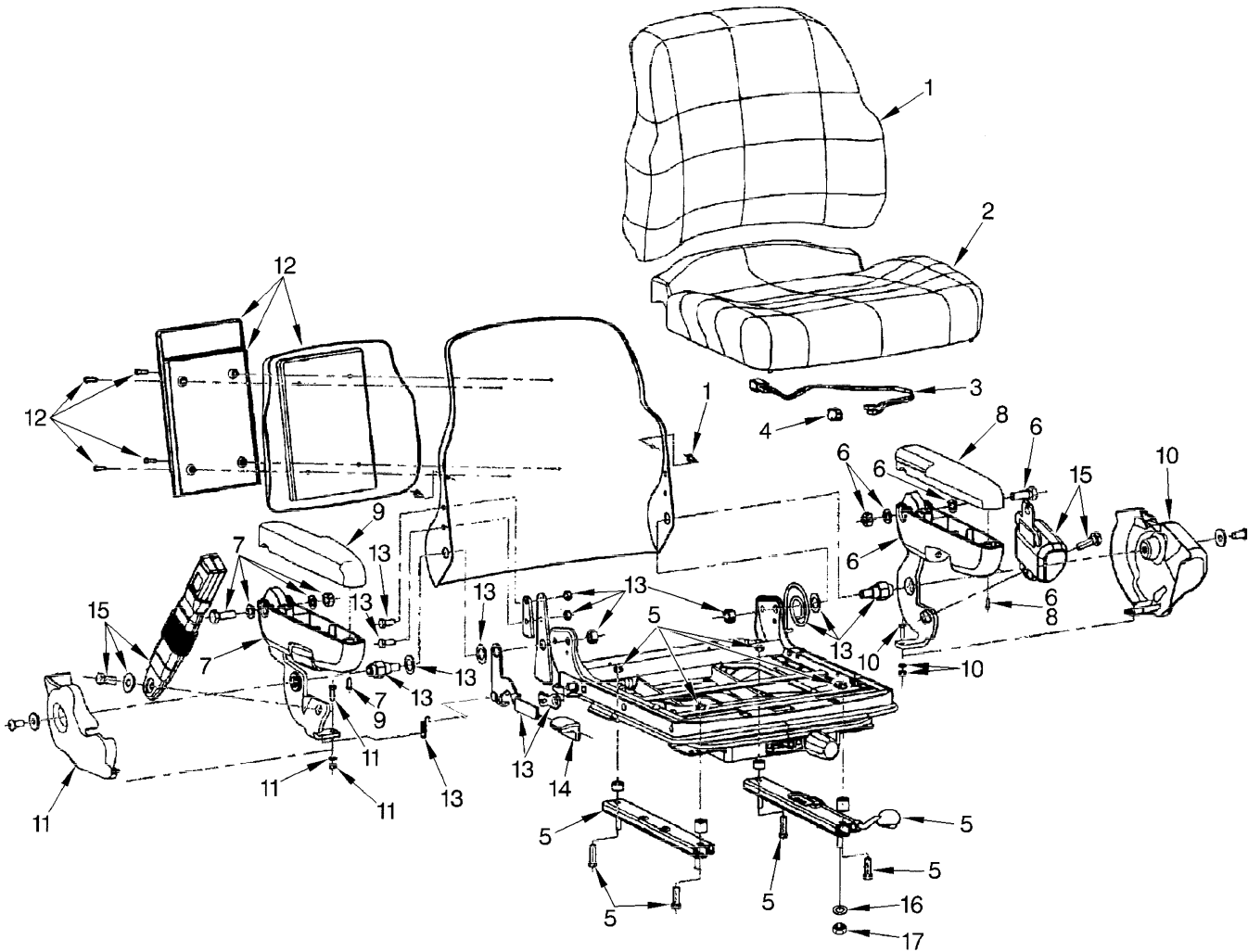

YP120121

SUSPENSION SEAT

ITEM	PART NO.	DESCRIPTION	QTY
	1466006	Full Suspension Seat.....	1
	1466007	Full Suspension Seat.....	1
1	1467533	Back Cushion (Vinyl)	1
1	1467535	Back Cushion (Fabric)	1
2	1494076	Seat Cushion (Vinyl).....	1
2	1467536	Seat Cushion (Fabric)	1
3	1467515	Wire Harness	1
3	1330409	Connector	1
3	1330414	Secondary Lock.....	1
4	1467514	Switch	1
5	1467513	Slider Kit.....	1
6	1467516	Armrest (LH) (LH).....	1
7	1467517	Armrest (RH) (RH)	1
8	1467518	Cap (LH).....	1
9	1467519	Cap (RH)	1
10	1467520	Cover (LH).....	1
11	1467521	Cover (RH)	1
12	1467522	Holder Kit.....	1
13	1467530	Recliner Kit.....	1
14	1467531	Recliner Knob.....	1
15	1467532	Seat Belt Kit.....	1
16	15175	Washer	4
17	145639	Nut	4
	a 893818	Ground Wire	1

FOOTNOTES:

a Not Illustrated

BUY NOW

**Then Instant Download
the Complete Manual
Thank you very much!**