

1842GV & 1842HV SABRE YARD TRACTORS



TECHNICAL MANUAL

John Deere
Worldwide Commercial And
Consumer Products Divison
TM1740 (01Jan98)



M89683

Sabre 1842HV Yard Tractor

Safety



Specifications and Information



Engine—Briggs & Stratton



Electrical



Power Train (Gear)



Power Train (Hydrostatic)



Steering



Brakes



Attachments



Miscellaneous





RECOGNIZE SAFETY INFORMATION



This is the safety-alert symbol. When you see this symbol on your machine or in this manual, be alert to the potential for personal injury.

Follow recommended precautions and safe servicing practices.

• UNDERSTAND SIGNAL WORDS

A signal word—DANGER, WARNING, or CAUTION—is used with the safety-alert symbol.

- **DANGER** identifies the most serious hazards. Danger or Warning safety signs are located near specific hazards.
- **CAUTION** safety signs are used where general precautions should be used. CAUTION also calls attention to safety messages in this manual.

REPLACE SAFETY SIGNS

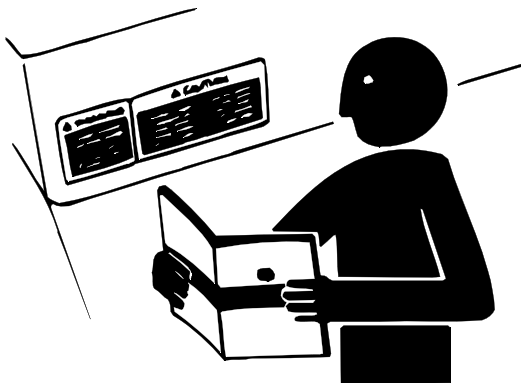

Replace missing or damaged safety signs. See the machine operator's manual for correct safety sign placement.

HANDLE FLUIDS SAFELY-AVOID FIRES

• BE PREPARED FOR EMERGENCIES

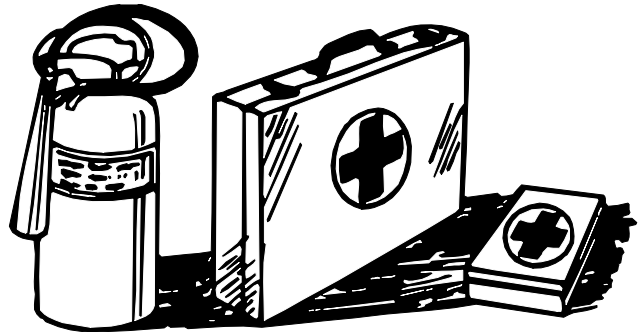

When you work around fuel, do not smoke or work near heaters or other fire hazards.

Store flammable fluids away from fire hazards. Do not incinerate or puncture pressurized containers.

Make sure machine is clean of trash, grease, and debris.

Do not store oily rags; they can ignite and burn spontaneously.

Be prepared if a fire starts.

Keep a first aid kit and fire extinguisher handy.

Keep emergency numbers for doctors, ambulance service, hospital, and fire department near your telephone.

USE SAFE SERVICE PROCEDURES

• WEAR PROTECTIVE CLOTHING

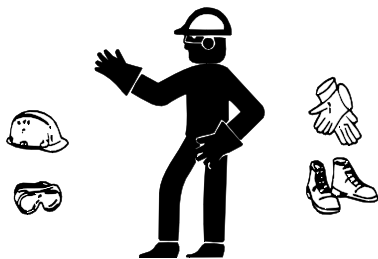

Wear close fitting clothing and safety equipment appropriate to the job.

Prolonged exposure to loud noise can cause impairment or loss of hearing. Wear a suitable hearing protective device such as earmuffs or earplugs to protect against objectionable or uncomfortable loud noises.

Operating equipment safely requires the full attention of the operator. Do not wear radio or music headphones while operating machine.

• SERVICE MACHINES SAFELY

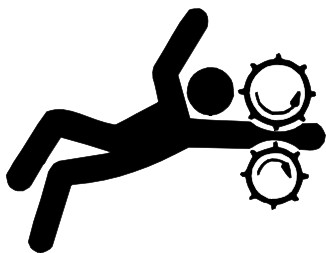

Tie long hair behind your head. Do not wear a necktie, scarf, loose clothing, or necklace when you work near machine tools or moving parts. If these items were to get caught, severe injury could result.

Remove rings and other jewelry to prevent electrical shorts and entanglement in moving parts.

• USE PROPER TOOLS

Use tools appropriate to the work. Makeshift tools and procedures can create safety hazards. Use power tools only to loosen threaded parts and fasteners. For loosening and tightening hardware, use the correct size tools. **DO NOT** use U.S. measurement tools on metric fasteners. Avoid bodily injury caused by slipping wrenches. Use only service parts meeting John Deere specifications.

• PARK MACHINE SAFELY

Before working on the machine:

1. Be sure all equipment is resting firmly on the ground.
1. Stop the engine.
1. Disconnect the spark plug.
1. Hang a "DO NOT OPERATE" tag in operator station.

• SUPPORT MACHINE PROPERLY AND USE PROPER LIFTING EQUIPMENT

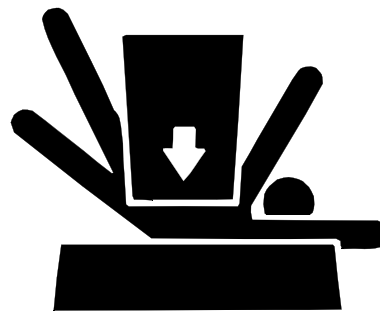

If you must work on a lifted machine or attachment, securely support the machine or attachment.

Do not support the machine on cinder blocks, hollow tiles, or props that may crumble under continuous load. Do not work under a machine that is supported solely by a jack. Follow recommended procedures in this manual.

Lifting heavy components incorrectly can cause severe injury or machine damage. Follow recommended procedure for removal and installation of components in the manual.

• WORK IN A CLEAN AREA

Before starting a job:

1. Clean work area and machine.
1. Make sure you have all necessary tools to do your job.
1. Have the right parts on hand.
1. Read all instructions thoroughly; do not attempt shortcuts.

• USING HIGH PRESSURE WASHERS

Directing pressurized water at electronic/electrical components or connectors, bearings, hydraulic seals, fuel injection pumps or other sensitive parts and components may cause product malfunctions. Reduce pressure and spray at a 45 to 90 degree angle.





- **Illuminate Work Area Safely**

Illuminate your work area adequately but safely. Use a portable safety light for working inside or under the machine. Make sure the bulb is enclosed by a wire cage. The hot filament of an accidentally broken bulb can ignite spilled fuel or oil.

- **Work In Ventilated Area**

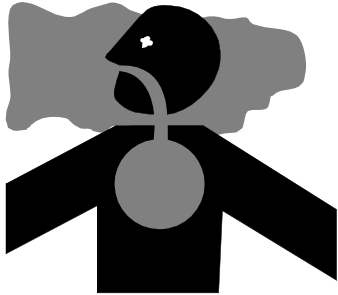

Engine exhaust fumes can cause sickness or death. If it is necessary to run an engine in an enclosed area, remove the exhaust fumes from the area with an exhaust pipe extension.

If you do not have an exhaust pipe extension, open the doors and get outside air into the area.

WARNING: California Proposition 65

Gasoline engine exhaust from this product contains chemicals known to the State of California to cause cancer, birth defects, or other reproductive harm.

- **Remove Paint Before Welding Or Heating**

Avoid potentially toxic fumes and dust. Hazardous fumes can be generated when paint is heated by welding, soldering, or using a torch. Do all work outside or in a well ventilated area. Dispose of paint and solvent properly. Remove paint before welding or heating: If you sand or grind paint, avoid breathing the dust. Wear an approved respirator. If you use solvent or paint stripper, remove stripper with soap and water before welding. Remove solvent or paint stripper containers and other flammable material from area. Allow fumes to disperse at least 15 minutes before welding or heating.

- **Avoid Harmful Asbestos Dust**

Avoid breathing dust that may be generated when handling components containing asbestos fibers. Inhaled asbestos fibers may cause lung cancer.

Components in products that may contain asbestos fibers are brake pads, brake band and lining assemblies, clutch plates, and some gaskets. The asbestos used in these components is usually found in a resin or sealed in some way. Normal handling is not hazardous as long as airborne dust containing asbestos is not generated.

Avoid creating dust. Never use compressed air for cleaning. Avoid brushing or grinding material containing asbestos. When servicing, wear an approved respirator. A special vacuum cleaner is recommended to clean asbestos. If not available, apply a mist of oil or water on the material containing asbestos. Keep bystanders away from the area.

SERVICE TIRES SAFELY



Explosive separation of a tire and rim parts can cause serious injury or death.

Do not attempt to mount a tire unless you have the proper equipment and experience to perform the job. Always maintain the correct tire pressure. Do not inflate the tires above the recommended pressure. Never weld or heat a wheel and tire assembly. The heat can cause an increase in air pressure resulting in a tire explosion. Welding can structurally weaken or deform the wheel.

When inflating tires, use a clip-on chuck and extension hose long enough to allow you to stand to one side and NOT in front of or over the tire assembly. Use a safety cage if available.

Check wheels for low pressure, cuts, bubbles, damaged rims or missing lug bolts and nuts.

AVOID INJURY FROM ROTATING TINES

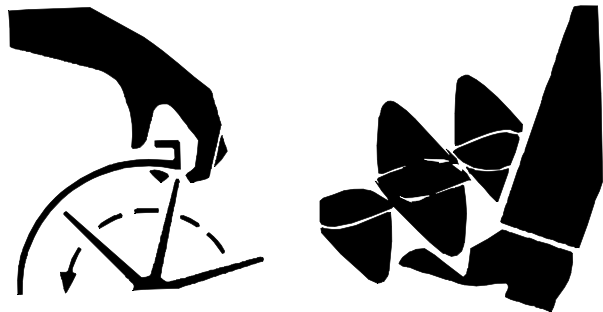

Keep hands and feet away while machine is running. Shut off engine before starting service. Do not defeat safety systems to allow machine to operate unattended.

HANDLE CHEMICAL PRODUCTS SAFELY

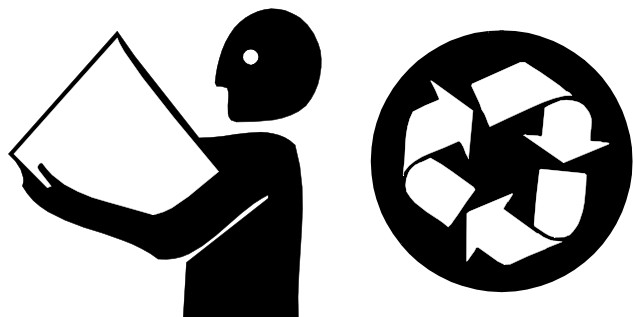

Direct exposure to hazardous chemicals can cause serious injury. Potentially hazardous chemicals used with John Deere equipment include such items as lubricants, coolants, paints, and adhesives.

A Material Safety Data Sheet (MSDS) provides specific details on chemical products: physical and health hazards, safety procedures, and emergency response techniques. Check the MSDS before you start any job using a hazardous chemical. That way you will know exactly what the risks are and how to do the job safely. Then follow procedures and recommended equipment.

• Dispose of Waste Properly

Improperly disposing of waste can threaten the environment and ecology. Potentially harmful waste used with John Deere equipment include such items as oil, fuel, coolant, brake fluid, filters, and batteries. Use leakproof containers when draining fluids. Do not use food or beverage containers that may mislead someone into drinking from them. Do not pour waste onto the ground, down a drain, or into any water source. Inquire on the proper way to recycle or dispose of waste from your local environmental or recycling center, or from your John Deere dealer.

LIVE WITH SAFETY



Before returning machine to customer, make sure machine is functioning properly, especially the safety systems. Install all guards and shields.



CONTENTS

	Page
GENERAL VEHICLE SPECIFICATIONS	3
METRIC FASTENER TORQUE VALUES	5
INCH FASTENER TORQUE VALUES	6
GASOLINE— NORTH AMERICA	7
GASOLINE STORAGE— NORTH AMERICA	7
GASOLINE—EUROPE	8
GASOLINE STORAGE—EUROPE	8
ENGINE OIL—NORTH AMERICA	9
ENGINE OIL—EUROPE	9
ENGINE BREAK-IN OIL— NORTH AMERICA	10
ENGINE BREAK-IN OIL— EUROPE	11
ANTI-CORROSION GREASE	12
ALTERNATIVE LUBRICANTS	12
SYNTHETIC LUBRICANTS	12
LUBRICANT STORAGE	12
MIXING OF LUBRICANTS	12
CHASSIS GREASE—NORTH AMERICA	13
CHASSIS GREASE—EUROPE	13
HYDROSTATIC TRANSMISSION OIL—NORTH AMERICA	14
HYDROSTATIC TRANSMISSION OIL—EUROPE	14
GEAR TRANSMISSION GREASE—NORTH AMERICA	15
GEAR TRANSMISSION GREASE—EUROPE	15
PRODUCT IDENTIFICATION LOCATIONS	16
PRODUCT IDENTIFICATION NUMBER (PIN)	16
ENGINE IDENTIFICATION NUMBER—BRIGGS & STRATTON	16
HYDROSTATIC TRANSAXLE IDENTIFICATION NUMBER	16
GEAR TRANSAXLE IDENTIFICATION NUMBER	16





GENERAL VEHICLE SPECIFICATIONS

ENGINE

Make Briggs & Stratton
 Model Name Vanguard V-Twin
 Model Number 350777
 Horsepower 13.42 kW (18 hp)
 Displacement 570 mL (34.7 cu. in.)
 Oil Capacity
 w/o Oil Filter 1.42 L (1.5 qt.)
 w/ Oil Filter 1.65 L (1.7 qt.)
 Cylinders 2
 Stroke/Cycle 4
 Valves Overhead Valves
 Lubrication Fully Pressurized
 Oil Filter Single Element, Full Flow, Spin-On Filter
 Cooling System Air Cooled
 Air Cleaner Dual Stage (Paper Element w/Replaceable Outer Foam Pre-cleaner)
 Muffler Horizontal Discharge Below Frame



FUEL SYSTEM

Aspiration Natural
 Fuel Tank Location Rear
 Fuel Tank Capacity 11 L (3 U.S. gal)
 Fuel (Minimum Octane) Unleaded Gasoline, 87 Octane
 Fuel Delivery Float-Type Side Draft Carburetor
 Fuel Filter Replaceable In-Line

ELECTRICAL

Ignition Electronic Capacitor Discharge Ignition (CDI)
 Type of Starter Solenoid Shift
 Charging System Flywheel Alternator
 Charging Capacity 10 amp, Regulated
 Battery Type BCI Group, U1
 Battery Voltage 12 VDC
 Battery Reserve Capacity at 25 Amp 38 minutes
 Battery Cold Cranking Amps at -18° C (0° F) 295 amps

STEERING

Type Sector and Pinion

BRAKES

Location Transaxle
 Type External Band, Single Pedal
 Park Brake Right Pedal, Clutch Interlock

IMPLEMENT LIFT

Lift System Manual with Lift-Assist Spring
 Lift Lever Location Left-hand side of hood



TRANSAXLE (GEAR-MODEL NUMBER 1842GV)

Model Peerless 820
 Speeds Forward 6
 Speeds Reverse 1
 Gear Speed Range
 Forward 1st 2.1 km/h (1.3 mph)
 2nd 3.0 km/h (1.9 mph)
 3rd 4.3 km/h (2.7 mph)
 4th 5.3 km/h (3.3 mph)
 5th 7.0 km/h (4.4 mph)
 6th 9.8 km/h (6.1 mph)
 Reverse 4.6 km/h (2.9 mph)

TRANSAXLE (HYDROSTATIC-MODEL NUMBER 1842HV)

Drive Train Belt Drive Transaxle with foot-controlled variable speed drive
 Transaxle Torq Model K-61
 Travel Speed-Forward 0-8.5 km/h (0-5.3 mph)
 Travel Speed-Reverse 0-3.5 km/h (0-2.5 mph)

PTO DRIVE

Type V-Belt
 Clutch Type Engine-Mounted, Electric
 Control Switch on dash

DIMENSIONS

Overall Height 112 cm (44.1 in.)
 Overall Length 181.6 cm (71.5 in.)
 Vehicle Weight (Gear Model Number 1842GV) 240 kg (528 lb)
 Vehicle Weight (Hydrostatic Model Number 1842HV) 241 kg (530 lb)



















TIRES

Size-Front 16 X 6.5
 Size-Rear 23 X 9.5

MOWER DECK (42-INCH)

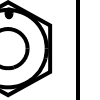
Blades-Rotary 2
 Cutting Height-Approx. 25 – 102 mm (1 – 4 in.)
 Blade Length 545.2 mm (21.46 in.)
 Cutting Width 1067 mm (42 in.)

METRIC FASTENER TORQUE VALUES

Property Class and Head Markings	4.8		8.8		9.8		10.9		12.9	
										
Property Class and Nut Markings	5		10		10		10		12	
										

TS1163

SIZE	Class 4.8				Class 8.8 or 9.8				Class 10.9				Class 12.9			
	Lubricated ^a		Dry ^a		Lubricated ^a		Dry ^a		Lubricated ^a		Dry ^a		Lubricated ^a		Dry ^a	
	N•m	lb-ft	N•m	lb-ft	N•m	lb-ft	N•m	lb-ft	N•m	lb-ft	N•m	lb-ft	N•m	lb-ft	N•m	lb-ft
M6	4.8	3.5	6	4.5	9	6.5	11	8.5	13	9.5	17	12	15	11.5	19	14.5
M8	12	8.5	15	11	22	16	28	20	32	24	40	30	37	28	47	35
M10	23	17	29	21	43	32	55	40	63	47	80	60	75	55	95	70
M12	40	29	50	37	75	55	95	70	110	80	140	105	130	95	165	120
M14	63	47	80	60	120	88	150	110	175	130	225	165	205	150	260	109
M16	100	73	125	92	190	140	240	175	275	200	350	225	320	240	400	300
M18	135	100	175	125	260	195	330	250	375	275	475	350	440	325	560	410
M20	190	140	240	180	375	275	475	350	530	400	675	500	625	460	800	580
M22	260	190	330	250	510	375	650	475	725	540	925	675	850	625	1075	800
M24	330	250	425	310	650	475	825	600	925	675	1150	850	1075	800	1350	1000
M27	490	360	625	450	950	700	1200	875	1350	1000	1700	1250	1600	1150	2000	1500
M30	675	490	850	625	1300	950	1650	1200	1850	1350	2300	1700	2150	1600	2700	2000
M33	900	675	1150	850	1750	1300	2200	1650	2500	1850	3150	2350	2900	2150	3700	2750
M36	1150	850	1450	1075	2250	1650	2850	2100	3200	2350	4050	3000	3750	2750	4750	3500

DO NOT use these hand torque values if a different torque value or tightening procedure is given for a specific application. Torque values listed are for general use only and include a ±10% variance factor. Check tightness of fasteners periodically. DO NOT use air powered wrenches.

Shear bolts are designed to fail under predetermined loads. Always replace shear bolts with identical grade.

Fasteners should be replaced with the same class. Make sure fastener threads are clean and that you properly start thread engagement. This will prevent them from failing when tightening.







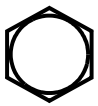

When bolt and nut combination fasteners are used, torque values should be applied to the **NUT** instead of the bolt head.

Tighten toothed or serrated-type lock nuts to the full torque value.

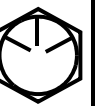
^a "Lubricated" means coated with a lubricant such as engine oil, or fasteners with phosphate and oil coatings. "Dry" means plain or zinc plated (yellow dichromate - Specification JDS117) without any lubrication.

Reference: JDS—G200.

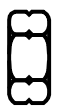
INCH FASTENER TORQUE VALUES

SAE Grade and Head Markings	1 or 2 ^b No Marks 	5  5.1  5.2 	8  8.2 
	2 No Marks 	5  	8  

TS1162

SIZE	Grade 1		Grade 2 ^b				Grade 5, 5.1 or 5.2				Grade 8 or 8.2					
	Lubricated ^a		Dry ^a		Lubricated ^a		Dry ^a		Lubricated ^a		Dry ^a		Lubricated ^a		Dry ^a	
	N•m	lb-ft	N•m	lb-ft	N•m	lb-ft	N•m	lb-ft	N•m	lb-ft	N•m	lb-ft	N•m	lb-ft	N•m	lb-ft
1/4	3.7	2.8	4.7	3.5	6	4.5	7.5	5.5	9.5	7	12	9	13.5	10	17	12.5
5/16	7.7	5.5	10	7	12	9	15	11	20	15	25	18	28	21	35	26
3/8	14	10	17	13	22	16	27	20	35	26	44	33	50	36	63	46
7/16	22	16	28	20	35	26	44	32	55	41	70	52	80	58	100	75
1/2	33	25	42	31	53	39	67	50	85	63	110	80	120	90	150	115
9/16	48	36	60	45	75	56	95	70	125	90	155	115	175	130	225	160
5/8	67	50	85	62	105	78	135	100	170	125	215	160	215	160	300	225
3/4	120	87	150	110	190	140	240	175	300	225	375	280	425	310	550	400
7/8	190	140	240	175	190	140	240	175	490	360	625	450	700	500	875	650
1	290	210	360	270	290	210	360	270	725	540	925	675	1050	750	1300	975
1-1/8	470	300	510	375	470	300	510	375	900	675	1150	850	1450	1075	1850	1350
1-1/4	570	425	725	530	570	425	725	530	1300	950	1650	1200	2050	1500	2600	1950
1-3/8	750	550	950	700	750	550	950	700	1700	1250	2150	1550	2700	2000	3400	2550
1-1/2	1000	725	1250	925	990	725	1250	930	2250	1650	2850	2100	3600	2650	4550	3350

DO NOT use these hand torque values if a different torque value or tightening procedure is given for a specific application. Torque values listed are for general use only and include a ±10% variance factor. Check tightness of fasteners periodically. DO NOT use air powered wrenches.

Shear bolts are designed to fail under predetermined loads. Always replace shear bolts with identical grade.

Fasteners should be replaced with the same grade. Make sure fastener threads are clean and that you properly start thread engagement. This will prevent them from failing when tightening.

When bolt and nut combination fasteners are used, torque values should be applied to the **NUT** instead of the bolt head.

Tighten toothed or serrated-type lock nuts to the full torque value.

^a "Lubricated" means coated with a lubricant such as engine oil, or fasteners with phosphate and oil coatings. "Dry" means plain or zinc plated (yellow dichromate - Specification JDS117) without any lubrication.

^b "Grade 2" applies for hex cap screws (not hex bolts) up to 152 mm (6-in.) long. "Grade 1" applies for hex cap screws over 152 mm (6-in.) long, and for all other types of bolts and screws of any length.

Reference: JDS—G200.

BUY NOW

**Then Instant Download
the Complete Manual
Thank you very much!**