

# T M

## Technical Manual

### John Deere JD670 Motor Grader

TM-1134



## SECTION AND GROUP CONTENTS OF THIS MANUAL

### SECTION I - GENERAL INFORMATION

- Group I - Contents, Index and Page List
- Group II - Introduction and Safety Information
- Group III - General Specifications
- Group IV - Predelivery, Delivery and After-Sale Services
- Group V - Lubrication

### SECTION 1 - WHEELS AND TIRES

- Group 0110 - Powered Wheels, Tires and Fastenings
- Group 0120 - Non-Powered Wheels, Tires and Fastenings
- Group 0199 - Specifications and Special Tools

### SECTION 2 - AXLES AND SUSPENSION SYSTEMS

- Group 0201 - Drive Axle Housings
- Group 0210 - Differential
- Group 0230 - Non-Powered Wheel Axles
- Group 0250 - Axle Shaft, Bearings and Reduction Gears
- Group 0299 - Specifications and Special Tools

### SECTION 3 - TRANSMISSION

- Group 0315 - Controls
- Group 0341 - Housings and Covers
- Group 0350 - Gears, Shafts, Bearings and Power Shift Clutch
- Group 0360 - Transmission Hydraulics
- Group 0370 - Clutch Disconnect and Controls
- Group 0399 - Specifications and Special Tools

### SECTION 4 - ENGINES

- Group 0400 - Removal and Installation
- Group 0401 - Crankshaft and Main Bearings
- Group 0402 - Camshafts and Valve Actuating Means
- Group 0403 - Connecting Rods and Pistons
- Group 0404 - Cylinder Block
- Group 0407 - Engine Oiling System
- Group 0408 - Ventilating System
- Group 0409 - Cylinder Head and Valves
- Group 0410 - Exhaust Manifold
- Group 0413 - Fuel Injection System
- Group 0414 - Intake Manifold
- Group 0416 - Turbocharger
- Group 0417 - Water Pump
- Group 0418 - Thermostats, Housings and Piping
- Group 0419 - Engine Oil Cooler
- Group 0420 - Fuel Filter and Primer Pump
- Group 0421 - Fuel Transfer Pump
- Group 0422 - Starting System
- Group 0433 - Flywheel, Housing and Fasteners
- Group 0499 - Specifications and Special Tools

### SECTION 5 - ENGINE AUXILIARY SYSTEMS

- Group 0505 - Cold Weather Starting Aids
- Group 0510 - Engine Cooling Systems
- Group 0515 - Speed Controls
- Group 0520 - Intake System
- Group 0560 - External Fuel Supply Systems
- Group 0599 - Specifications and Special Tools

### SECTION 8 - TRANSFER DRIVE

- Group 0841 - Housings and Covers
- Group 0851 - Gears, Shafts and Bearings
- Group 0899 - Specifications and Special Tools

### SECTION 9 - STEERING SYSTEM

- Group 0960 - Power Steering
- Group 0999 - Specifications and Special Tools

### SECTION 10 - SERVICE BRAKES

- Group 1011 - Service Brakes Active Elements
- Group 1015 - Controls Linkage
- Group 1066 - Brakes Hydraulics
- Group 1099 - Specifications and Special Tools

### SECTION 11 - PARKING-EMERGENCY BRAKES

- Group 1111 - Parking Brake Active Elements
- Group 1115 - Controls Linkage
- Group 1199 - Specifications and Special Tools

### SECTION 15 - EQUIPMENT ATTACHING

- Group 1511 - Drawbar

### SECTION 16 - ELECTRICAL SYSTEMS

- Group 1671 - Batteries, Support and Cables
- Group 1672 - Alternator, Regulator and Charging System Wiring
- Group 1673 - Vehicle Lighting System
- Group 1674 - Wiring Harness and Switches
- Group 1675 - Automatic Control Systems and Controls
- Group 1676 - Instrument and Indicators
- Group 1699 - Specifications and Special Tools

### SECTION 17 - FRAME, CHASSIS OR SUPPORTING STRUCTURE

- Group 1740 - Frame Installation
- Group 1746 - Bottom Guards
- Group 1799 - Specifications and Special Tools

## **SECTION AND GROUP CONTENTS OF THIS MANUAL—Continued**

### **SECTION 18 - OPERATOR'S STATION**

- Group 1806 - Safety Equipment
- Group 1808 - Comfort and Convenience Items
- Group 1810 - Operator Enclosure
- Group 1821 - Seat
- Group 1830 - Heating
- Group 1899 - Specifications and Special Tools

### **SECTION 19 - SHEET METAL**

- Group 1910 - Hood or Engine Enclosure
- Group 1921 - Grille and Grille Housing

### **SECTION 21 - MAIN HYDRAULIC SYSTEM**

- Group 2160 - Hydraulic System
- Group 2199 - Specifications and Special Tools

### **SECTION 34 - GRADING DEVICE**

- Group 3401 - Blade
- Group 3415 - Controls Linkage
- Group 3440 - Grading Device Frames
- Group 3450 - Circle Gear Box
- Group 3460 - Hydraulic System
- Group 3499 - Specifications and Special Tools

### **SECTION 42 - GROUND CONDITIONING TOOLS**

- Group 4201 - Teeth and Shanks
- Group 4215 - Controls Linkage
- Group 4240 - Frames
- Group 4260 - Hydraulic System
- Group 4299 - Specifications and Special Tools

### **SECTION 90 - SYSTEM TESTING**

- Group 9005 - General Information - Seven Basic Steps of Testing and Diagnosis
- Group 9010 - Engine
- Group 9015 - Electrical System
- Group 9020 - Power Train
- Group 9025 - Hydraulic System
- Group 9030 - Miscellaneous Components
- Group 9032 - Automatic Blade Control
- Group 9035 - Specifications and Special Tools

## MAINTENANCE WITHOUT ACCIDENT WORK SAFELY



T27999N

 This safety alert symbol identifies important safety messages in this manual and on the motor grader. When you see this symbol, be alert to the possibility of personal injury and carefully read the message that follows.

**EVERY EMPLOYER HAS A  
SAFETY PROGRAM. KNOW  
WHAT IT IS!**

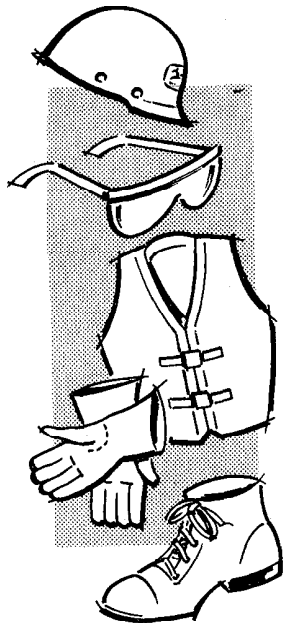

T27501

Consult your shop foreman for specific instructions on a job, and the safety equipment required.

For instance, you may need: Hard hat, safety shoes, safety goggles, heavy gloves, reflector vests, ear protectors, respirators.

Litho in U.S.A.



T27502N

### BE ALERT!

Plan ahead—work safely—know how to use a first-aid kit and a fire extinguisher—and where to get aid and assistance.

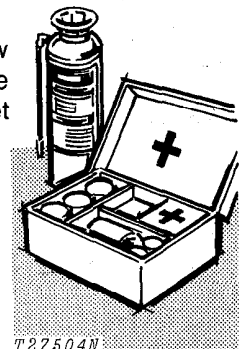

T27504N

### Maintenance Area

Make sure the maintenance area is adequately vented.

Keep maintenance area **CLEAN AND DRY**. Oily and wet floors are slippery; greasy rags are a fire hazard; wet spots are dangerous when working with electrical equipment.

Store starting aids in a cool and well-ventilated place, out of the reach of unauthorized personnel.

## MAINTENANCE WITHOUT ACCIDENT

### AVOID FIRE HAZARDS—

#### Fuel Is Dangerous!

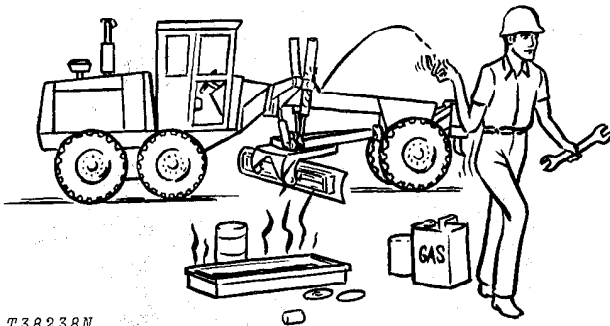

T38238N

Don't smoke while refueling.

Don't smoke while handling highly flammable material.

Engine should be shut off when refueling.

Use care in refueling if the engine is hot.

Don't use open pans of gasoline or diesel fuel for cleaning parts. Good commercial, nonflammable solvents are preferred.

#### Battery Gas Is Highly Flammable!

Provide adequate ventilation when charging batteries.

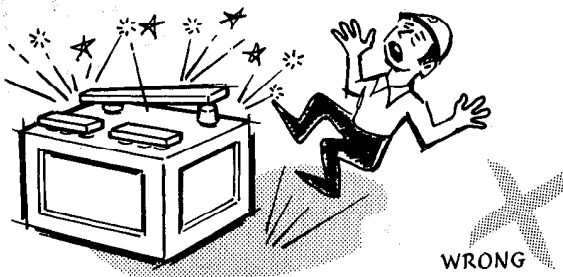

T27506N

Don't check battery charge by placing metal objects across the posts.

Don't allow sparks or open flame near batteries.

Don't smoke near battery.

#### Flame Is Not a Flashlight!

**NEVER USE OPEN FLAME AROUND THE MACHINE.**

**KNOW WHERE FIRE EXTINGUISHERS ARE KEPT!**

Litho in U.S.A.

### UNDER ALL MAINTENANCE CONDITIONS—

Do not perform any work on the equipment unless authorized to do so. Then be sure you know the safe and proper procedure.

Follow recommended procedures.

Never service the equipment while it is being operated.

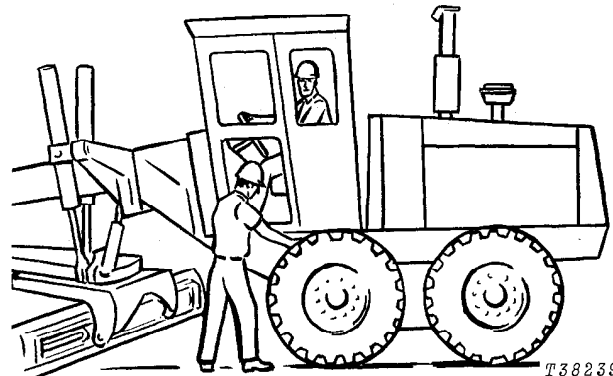

T38239N

Avoid working on equipment with the engine running.

If it is necessary to make checks with the engine running, **ALWAYS USE TWO** service technicians—one, the operator, at the controls, the other checking within sight of the operator.

#### KEEP HANDS AWAY FROM MOVING PARTS

Support all raised equipment.

Never work under raised blade, ripper, or scarifier.

Lower all equipment to ground.

If the machine is on an incline, block it securely.

Use hoisting equipment for lifting heavy parts.

#### TAKE CARE! WATCH OUT FOR OTHER PEOPLE IN THE VICINITY

Wear safety glasses when drilling, grinding, or hammering metal.

## SERVICING PRECAUTIONS

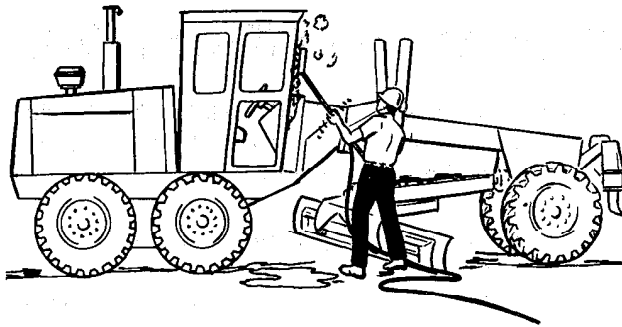

T38242N

Keep ALL equipment free of dirt and oil.

Be sure to clean any oil, grease, mud, ice, or snow from floor of operator's compartment, stepping points, and grab rails.

When preparing the engine for storage, remember that inhibitor is volatile and therefore dangerous. Seal and tape openings after adding the inhibitor. Keep container tightly closed when not in use.

Don't remove the radiator cap until coolant temperature is below the boiling point. Then turn cap slightly to relieve pressure before removing.

Periodically check exhaust system for excessive leakage.

Relieve hydraulic pressure before working on hydraulic system: shut off engine, lower all equipment to ground, and move control levers until no response is felt.

When checking hydraulic pressure, be sure to use the correct test gauge.

## PRECAUTIONS DURING REPAIR

Before working on hydraulic system relieve hydraulic pressure.

Before repairing the electrical system, or performing a major overhaul, disconnect batteries.

## KNOW EQUIPMENT IS READY!

Check guards, safety bars—all protective devices installed on the grader. Every one should be in place and secure.

## CHECK IT OUT!

- GUARDS
- SHIELDS
- PROTECTIVE DEVICES
- SEAT BELTS, ETC.

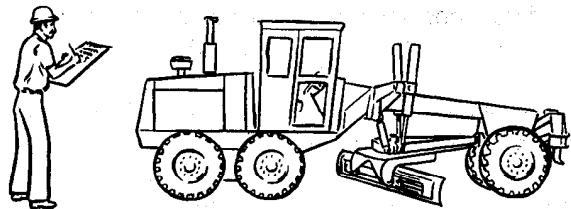

T38243N

Carefully inspect equipment for visual defects—leaks in fuel, lubrication, and hydraulic systems. Do not search for pressurized fluid leaks with your hands. Use cardboard or wood to search for leaks.

## Group III

# GENERAL SPECIFICATIONS

(Specifications and design subject to change without notice. Wherever applicable, specifications are in accordance with SAE Standards. Except where otherwise noted, these specifications are based on a unit equipped with 13.00-24, 8 ply rating, tubeless tires, 12 ft. (3.66 m) moldboard and standard equipment.)

Power @ 2300  
 engine rpm:           **SAE**  
 Gross ..... 135 (100.7 kW\*)  
 Net ..... 125 (93.2 kW\*)           126.7 PS

Net engine flywheel power is for an engine equipped with fan, air cleaner, water pump, lubricating-oil pump, fuel pump, alternator, and muffler. Gross engine power is without fan. Gross and net flywheel power ratings are under SAE standard conditions of 500 ft. (152 m) altitude and 85°F (29°C) temperature and DIN 70 020 standard conditions (non-corrected). No derating is required up to 10,000 ft. (3000 m).

\*In the international system of units (SI), power is expressed in kilowatts (kW).

Engine: John Deere turbocharged diesel, vertical 6-cylinder, valve-in-head, 4-stroke cycle.  
 Bore and stroke... 4.19 x 5 in. (106.5 x 127 mm)  
 Piston displacement ..... 414 cu. in. (6 784 cm<sup>3</sup>)  
 Compression ratio ..... 16.2 to 1  
 Maximum torque @ 1300 rpm ..... 372 lb-ft (504 Nm)  
 NACC or AMA (U.S. Tax) horsepower ..... 42.1  
 Main bearings ..... 7  
 Lubrication ..... Pressure system with full-flow filter  
 Cooling ..... Pressurized with thermostat and fixed bypass  
 Fan ..... Suction  
 Air cleaner with restriction indicator ..... Dry  
 Electrical system .... 24 volt (24 V) with alternator  
 Batteries (2) 12 volt ..... Reserve capacity: 180 minutes each  
 Transmission ..... Power Shift, 8 forward and 4 reverse selections  
 Differential Lock ..... Foot-operated, hydraulically-actuated  
 Final Drives ..... Inboard planetary

Travel Speeds (2,300 engine rpm, no tire slip):

| Shift Lever Position | mph  | km/h |
|----------------------|------|------|
| Forward 1            | 2.3  | 3.6  |
| 2                    | 3.2  | 5.1  |
| 3                    | 4.8  | 7.8  |
| 4                    | 6.3  | 10.1 |
| 5                    | 8.2  | 13.2 |
| 6                    | 10.5 | 17.0 |
| 7                    | 14.1 | 22.8 |
| 8                    | 23.9 | 38.4 |
| Reverse 1            | 2.8  | 4.5  |
| 2                    | 3.9  | 6.3  |
| 3                    | 5.9  | 9.5  |
| 4                    | 7.6  | 12.3 |

Brakes:

Service ..... Foot-operated, hydraulically actuated, wet-disk, effective on 4 tandem wheels  
 Parking ..... Foot-operated, mechanical, dry-disk effective on 4 tandem wheels

Steering:

Front ..... Full hydraulic power system  
 Range ..... 47.5 deg. left or right  
 Rear ..... Hydraulically-articulated frame steering (25 deg. left or right)  
 Turning radius ..... 22 ft. (6.7 m)

Hydraulic System: Closed-center

Standby pressure ..... 2,250 psi (155 bar)  
 Pump ..... Variable-displacement, 35 gpm (132 L/min.) @ 2,300 engine rpm  
 Circle: Welded angle, 4 ft. 10 in. (1.47 m) dia.  
 Rotation ..... 360 deg.  
 Drive ..... Hydraulic motor and worm gear  
 Drawbar ..... Welded box, 3.5x7x0.38 in. (89x178x10 mm) wall, with ball and socket pivot

Blade:  
 Length ..... 12 ft. (3.66 m)  
 Height ..... 24 in. (610 mm)  
 Thickness ..... 0.88 in. (22 mm)

Blade Lifting Mechanism:  
 Control ..... Dual lever, hydraulic  
 with float position  
 Cylinders (2) ..... 3.25 in. (82.6 mm) dia. bore;  
 44.87 in. (1.14 m) stroke

Blade Range:  
 Lift above ground ..... 1 ft. 4.10 in. (409 mm)  
 Blade side-shift:  
 Right or left ..... 2 ft. 2.9 in. (683 mm)

Shoulder reach outside wheels:  
 Right or left ..... 7 ft. (2.13 m)  
 Pitch ..... 35 deg. total

Lift arms:  
 Positions ..... 7  
 Control ..... Hydraulic, foot operated

Frame:  
 Rear main frame .. Welded box section from articu-  
 lation joint to main frame arch  
 Top and bottom plate, width ..... 8.25 in. (210 mm)  
 thickness 0.625 in. (15.9 mm)  
 Side plates, minimum height .... 13.15 in. (334 mm)  
 thickness 0.625 in. (15.9 mm)  
 Weight per ft., min. .... 93 lb. (42.2 kg)  
 Minimum vertical-section modulus .... 104.52 cu. in.  
 (1 713 cm<sup>3</sup>)  
 Front main frame .... Formed box section from main  
 frame arch to front hood  
 Width ..... 8.25 in. (210 mm)  
 Height, min. .... 12.3 in. (312 mm)  
 Thickness ..... 0.625 in. (15.9 mm)  
 Weight per ft., min. .... 75.6 lb. (34.3 kg)  
 Minimum vertical section modulus ..... 69.44 cu. in.  
 (1 138 cm<sup>3</sup>)

Tandems: Welded steel box section 27 in. (686 mm) x  
 7.56 in. (192 mm)  
 Drive ..... 2.00 in. (51 mm) pitch roller chain  
 Axle dia. at bearings ..... 3.63 in. (92.2 mm)  
 3.35 in. (85.1 mm)

Front Axle: Fabricated steel box-frame with steel spin-  
 dles, tapered roller bearings  
 Diameter at bearing seats ..... 3.54 in. (90 mm)  
 1.87 in. (48 mm)  
 Total oscillation ..... 30 deg.  
 Wheel lean (either direction) ..... 20 deg.

Rear Drive Axle: Full floating with tapered roller bear-  
 ings  
 Diameter at bearings ..... 3.35 in. (85 mm)  
 Tires ..... 13.00 - 24, 8, 10 and 12 ply-rating  
 8 in. (203 mm) rim  
 14.00 - 24, 10 and 12 ply-rating  
 8 or 10 in. (203 or 254 mm) rim  
 17.5 - 25 and 12 ply-rating  
 14 in. (356 mm) rim

Scarifier (Special Equipment): V-type for 4 ft. (1.22  
 m) cut with 3 manual pitch positions  
 Number of teeth ..... 5, 9 (possible)  
 Lift above ground ..... 22 in. (559 mm)  
 Penetration ..... 12 in. (305 mm)  
 Shank size ..... 1.25x4.0 in. (31.7x102 mm)

Ripper (Special Equipment): 8 ft. (2.44 m) cut width,  
 parallelogram linkage, 2 manual shank vertical posi-  
 tions.  
 Number of shank pockets ..... 5  
 Number of shanks ..... 3  
 Lift above ground ..... 14.5 in. (368 mm)  
 Penetration ..... 14 in. (356 mm)  
 Shank size ..... 2x5 in. (51x127 mm)  
 Lift above ground  
 (shank in upper position) ..... 23.5 in. (597 mm)

| Capacities:                             | U.S.    | Liters |
|---|---------|--------|
| Fuel tank                               | 60 gal. | 227    |
| Cooling system                          | 7 gal.  | 26.5   |
| Engine lubrication,<br>Including filter | 5 gal.  | 18.9   |
| Transmission-hydraulic<br>system        | 22 gal. | 83.3   |
| Tandem housings (each)                  | 4 gal.  | 15     |
| Worm gearbox                            | 3 qt.   | 2.8    |

| SAE<br>Operating<br>Weight                           | On Front<br>Wheels      | On Rear<br>Wheels        | Total                     |
|--|-------------------------|--------------------------|---------------------------|
| Standard<br>equipment ..                             | 7,653 lb.<br>(3 471 kg) | 18,177 lb.<br>(8 245 kg) | 25,830 lb.<br>(11 716 kg) |
| Standard<br>equipment<br>and<br>scarifier ....       | 8,687 lb.<br>(3 940 kg) | 18,177 lb.<br>(8 245 kg) | 26,944 lb.<br>(12 221 kg) |
| Standard<br>equipment,<br>scarifier<br>and ripper .. | 7,970 lb.<br>(3 615 kg) | 21,474 lb.<br>(9 740 kg) | 29,444 lb.<br>(13 356 kg) |



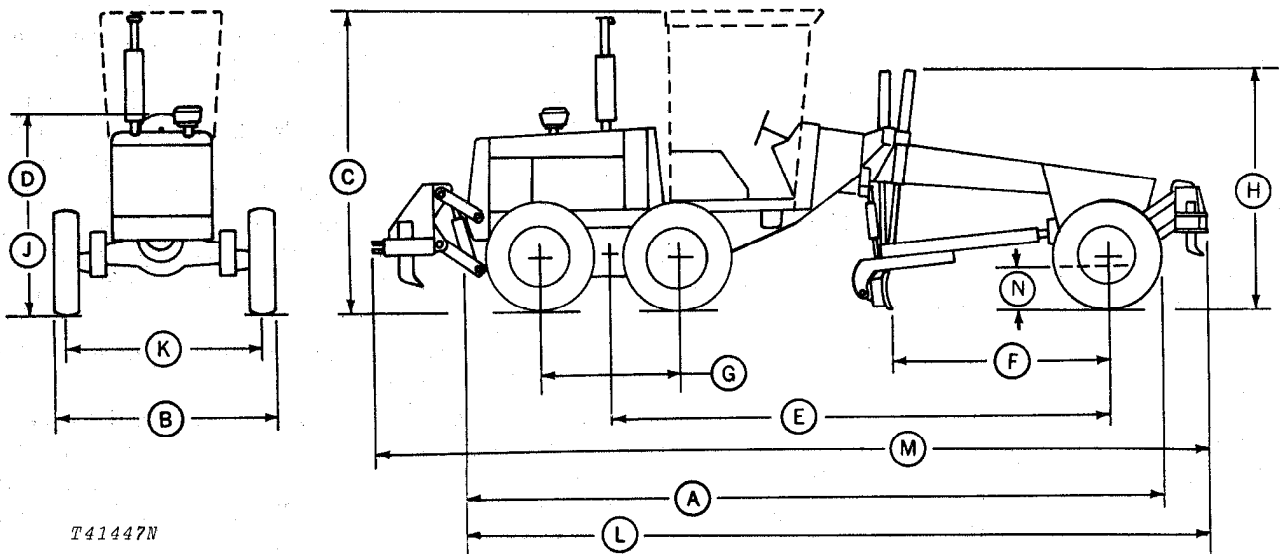

T41447N

**OVER-ALL DIMENSIONS**

- A. Length ..... 27 ft. 3.2 in. (8.31 m)
- B. Width (13.00 - 24 tires)  
 (Front and rear) ..... 7 ft. 10 in. (2.34 m)  
 Width (17.5 - 25 tires)  
 (Front and rear) ..... 8 ft. 6 in. (2.59 m)  
 Width (14.00 - 24 tires)  
 (Front and rear) ..... 8 ft. (2.44 m)
- C. Height (with Cab) ..... 10 ft. 6 in. (3.2 m)
- D. Height (without Cab - To  
 Top of Steering Wheel) .... 88.4 in. (2.24 m)
- E. Wheelbase ..... 19 ft. 7 in. (5.97 m)
- F. Blade base ..... 8 ft. 4 in. (2.54 m)
- G. Tandems (Center Line) .. 5 ft. 0.71 in. (1.54 m)
- H. Height (Top Lift Cylinders) .. 8 ft. 9.3 in. (2.67 m)
- J. Height (Top Pre-Cleaner) .... 93.75 in. (2.38 m)

**Additional Standard Equipment:**

- |  |                             |
|--|-----------------------------|
| Transistorized voltage regulator               | Gauges:                     |
| Lights (2 white front with stop and taillight) | Transmission pressure       |
| Mechanical hour meter                          | Water temperature           |
| Cigar lighter                                  | Transmission temperature    |
| Horn   | Engine oil pressure         |
| Deluxe seat                                    | Transmission lube           |
| Front windshield wiper                         | Fuel                        |
| Rear windshield wiper                          | Pre-cleaner                 |
| Work lights (2 front and 2 rear floods)        | ROPS with cab and seat belt |
| Turn signals                                   | 12 ft. (3.66 m) moldboard   |
| Cold weather starting aid                      | Engine side shields         |
| Vandal protection                              | Air filter indicator        |
|  | Floor mat                   |

**OVER-ALL DIMENSIONS**

- K. Tread  
 (Front) (13.00 - 24 tires) ... 76.6 in. (1.94 m)  
 (Front) (17.5 - 25 tires) ... 79.36 in. (2.01 m)  
 (Front) (14.00 - 24 tires) ... 76.6 in. (1.94 m)  
 (Rear) (13.00 - 24 tires) .. 79.61 in. (2.02 m)  
 (Rear) (17.5 - 25 tires) ... 82.37 in. (2.09 m)  
 (Rear) (14.00 - 24 tires) .. 79.61 in. (2.02 m)
- L. Length with Scarifier (In Up Position) ..... 29 ft. 2.6 in. (8.9 m)
- M. Length of Scarifier and Ripper (both in up position) ..... 31 ft. 8.2 in. (9.66 m)
- N. Front axle ground clearance  
 with 13.00 - 24 tires ..... 22 in. (559 mm)  
 with 17.5 - 25 tires ..... 23.2 in. (589 mm)  
 with 14.00 - 24 tires ..... 22.5 in. (571 mm)

- |  |  |
|--|--|
| Special Equipment:                     | Coolant heater                                 |
| Scarifier                              | Bench seat                                     |
| Cab heater                             | 2 ft. (610 mm)                                 |
| Cab defroster fan                      | moldboard extensions, right or left            |
| ROPS with canopy and seat belt         | Engine disconnect                              |
| Rear-mounted ripper with drawbar hitch | Overlay end bits                               |
| Below-cab blade lights (2)             | Transmission bottom guard                      |
| Reverse warning alarm                  | Drawbar hitch                                  |
| Tool box                               | 3 in. (76 mm) seat belt                        |
| Sound baffles for engine side shields  | 13 ft. (3.96 m) and 14 ft. (4.27 m) moldboards |
| Heavy-duty cutting edges               | Articulation indicator                         |

**BUY NOW**

**Then Instant Download  
the Complete Manual  
Thank you very much!**