

# **MITSUBISHI FORKLIFT TRUCKS**

---

## **SERVICE MANUAL**

<b>FG15K</b>	EF31A-60001-up
<b>FD15K</b>	EF16B-65001-up
<b>FG18K</b>	EF31A-85001-up
<b>FD18K</b>	EF16B-85001-up
<b>FG20K</b>	EF17B-15001-up
<b>FD20K</b>	EF18B-15001-up
<b>FG25K</b>	EF17B-65001-up
<b>FD25K</b>	EF18B-65001-up
<b>FG30K</b>	EF13D-45001-up
<b>FD30K</b>	EF14C-45001-up
<b>FG35K</b>	EF13D-65001-up
<b>FD35K</b>	EF14C-65001-up

### **NOTE**

For use with the 4G63/4G64  
Gasoline Engine Service Manual.

For use with the S4Q2/S4S  
Diesel Engine Service Manual.

**AC  
CHASSIS  
MAST**

## GROUP INDEX

Group	Items
<b>GENERAL INFORMATION</b>	Vehicle Exterior, Models, Serial Number Locations, Dimensions, Technical Data
<b>COOLING SYSTEM</b>	Fan Belt Removal, Fan Belt Inspection, Fan Belt Adjustment
<b>ELECTRICAL SYSTEM</b>	Console Box, Combination Meter, Starter Switch (with Anti-restart Lock), Lighting Switch, Fuse Box, Spare Terminals, Battery Maintenance, Light Bulb Specifications, Electrical System Schematics
<b>POWER TRAIN</b>	Engine and Transmission
<b>POWERSHIFT TRANSMISSION</b>	Hydraulic Circuit, Control, Transmission Assembly, Pump Assembly, Control Valve, Testing Hydraulic Pressure, Adjusting Inching Pedal, Testing Clutch Valve, 10-m (33-ft) Start Acceleration Test
<b>FRONT AXLE AND REDUCTION DIFFERENTIAL</b>	Front Wheels, Front Axle and Reduction Differential, Tooth Contact Patterns and Adjustment
<b>REAR AXLE</b>	Rear Axle, Steering Cylinder, Rear Wheels, Rear Axle, Steering Cylinder, Minimum Turning Radius Adjustment
<b>BRAKE SYSTEM</b>	Automatic Adjusting Device, Brake Pedal and Assembly, Master Cylinder, Wheel Brakes, Wheel Cylinders, Brake Pedal Adjustment, Bleeding Air Out of the Brake Fluid Line, Brake Test
<b>STEERING SYSTEM</b>	Steering System, Steering Control Valve, Tilt Steering Assembly
<b>HYDRAULIC SYSTEM</b>	Hydraulic Line, Hydraulic Tank, Hydraulic Pump, Control Valve, Lift and Tilt Cylinders, Down Safety Valve
<b>MAST AND FORK</b>	Simplex Mast, Duplex Mast, Triplex Mast
<b>SERVICE DATA</b>	Tightening Torques for Standard Bolts and Nuts, Periodic Replacement Parts, Fuel and Lubricant Specifications, Recommended Brands of Lubricants, Refill Capacities (Approximate)
<b>OPTIONS</b>	Plate Fin Type Radiator Kit, Fan Speed Up Kit, Radiator Coolant Level, Warning Kit, Torque Converter Oil Filter Kit, Radiator Net Kit, Combination Lamp and Turn Signal Switch Kit, Back Buzzer Kit, etc.

**1**

**2**

**3**

**4**

**5**

**6**

**7**

**8**

**9**

**10**

**11**

**12**

**13**

## GENERAL INFORMATION

Vehicle Exterior .....	1 - 1
Models .....	1 - 1
Serial Number Locations .....	1 - 2
Dimensions.....	1 - 4
Technical Data (Standard Models) .....	1 - 6

## Vehicle Exterior

- This Service Manual deals with all components or systems of the Mitsubishi Forklift Trucks; except for the engine and attachment, which are covered in the respective manuals.

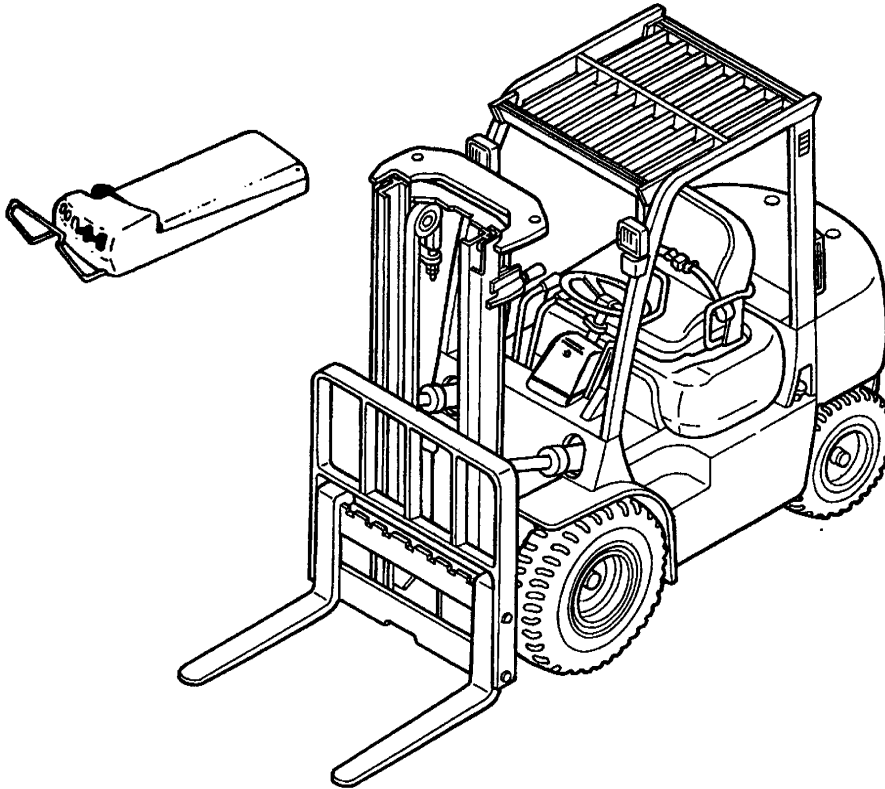

207151A

## Models

- This Service Manual furnishes servicing and maintenance information for the following trucks:

Truck Model	Serial Number	Engine Mounted
FG15K	EF31A-60001-up	Mitsubishi 4G63 Gasoline Engine
FD15K	EF16B-65001-up	Mitsubishi S4Q2 Diesel Engine
FG18K	EF31A-85001-up	Mitsubishi 4G63 Gasoline Engine
FD18K	EF16B-85001-up	Mitsubishi S4Q2 Diesel Engine
FG20K	EF17B-15001-up	Mitsubishi 4G63 Gasoline Engine
FD20K	EF18B-15001-up	Mitsubishi S4S Diesel Engine
FG25K	EF17B-65001-up	Mitsubishi 4G63 Gasoline Engine
FD25K	EF18B-65001-up	Mitsubishi S4S Diesel Engine
FG30K	EF13D-45001-up	Mitsubishi 4G64 Gasoline Engine
FD30K	EF14C-45001-up	Mitsubishi S4S Diesel Engine
FG35K	EF13D-65001-up	Mitsubishi 4G64 Gasoline Engine
FD35K	EF14C-65001-up	Mitsubishi S4S Diesel Engine

GENERAL INFORMATION

Serial Number Locations

Nameplate

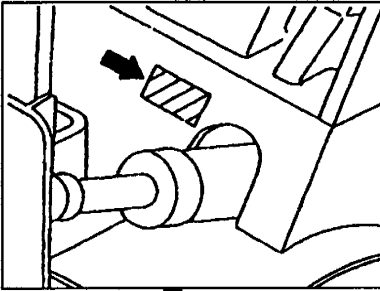

Chassis Serial Number

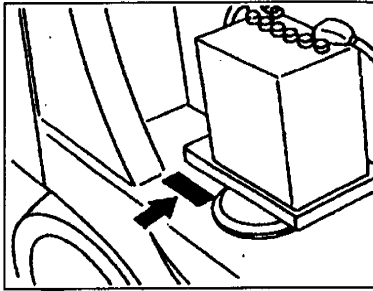

Engine Serial Number  
(gasoline models)

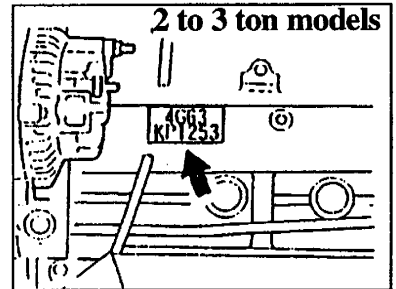
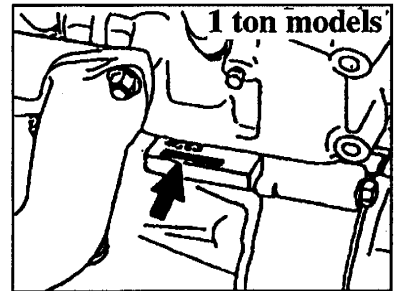

Engine Serial Number  
(diesel models)

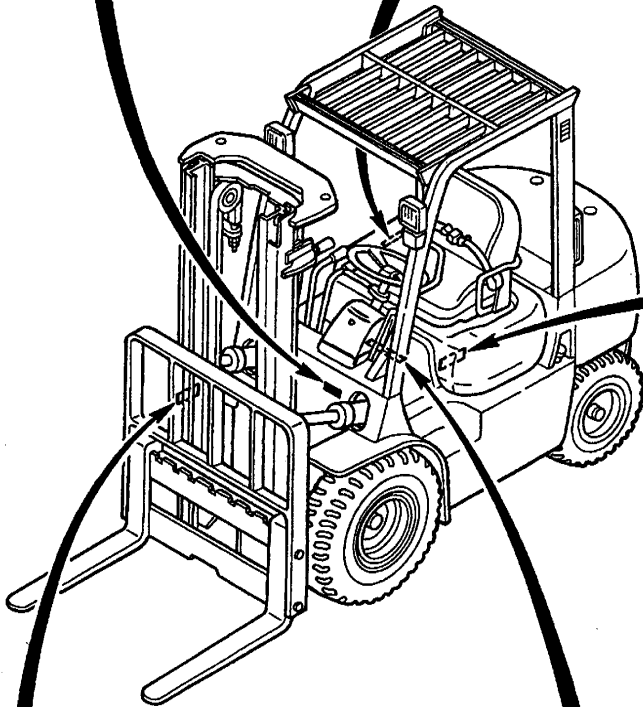
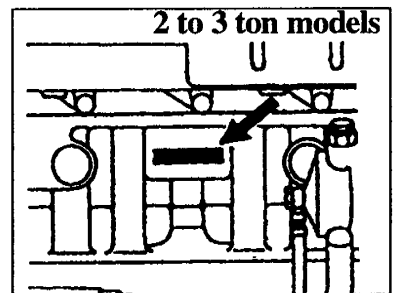
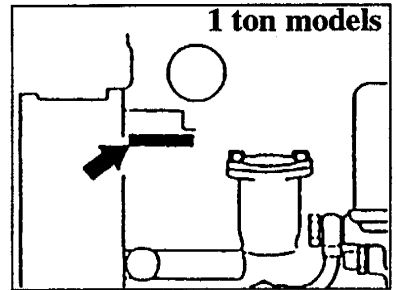

Mast Serial Number

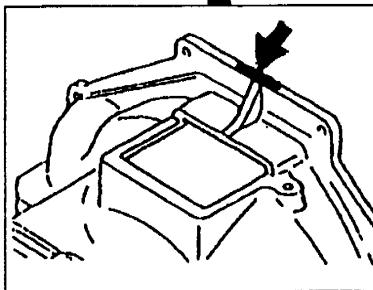
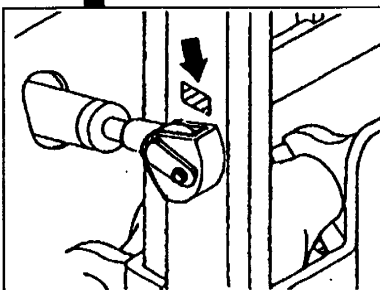

Transmission Serial Number

207236

### Chassis and Mast Model Identification

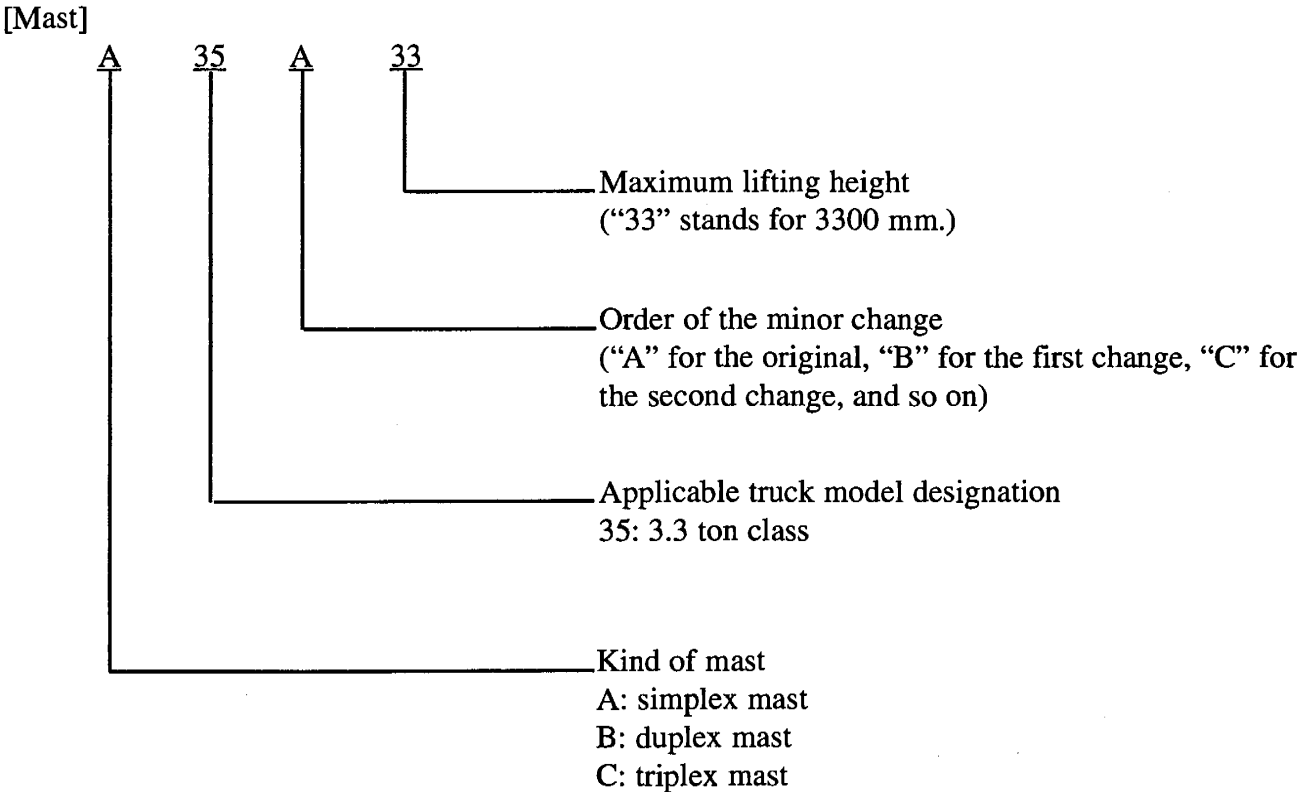
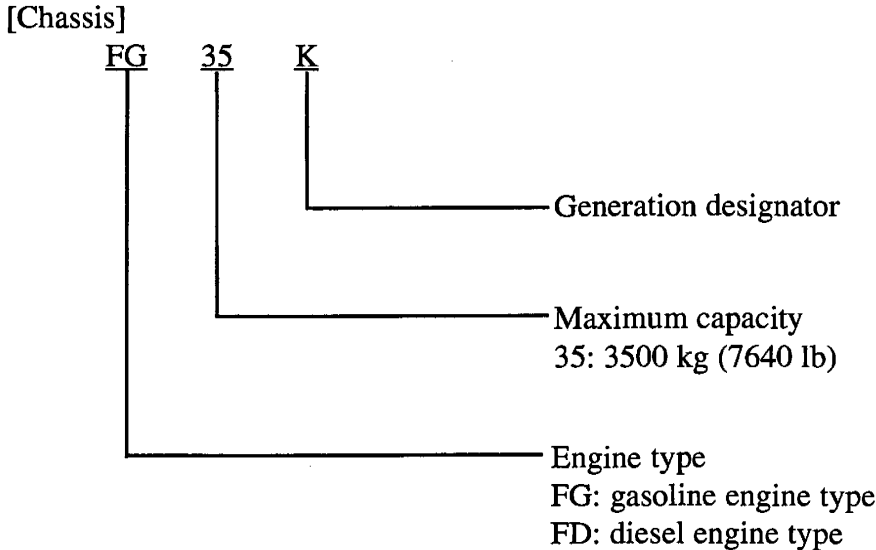

GENERAL INFORMATION

Dimensions

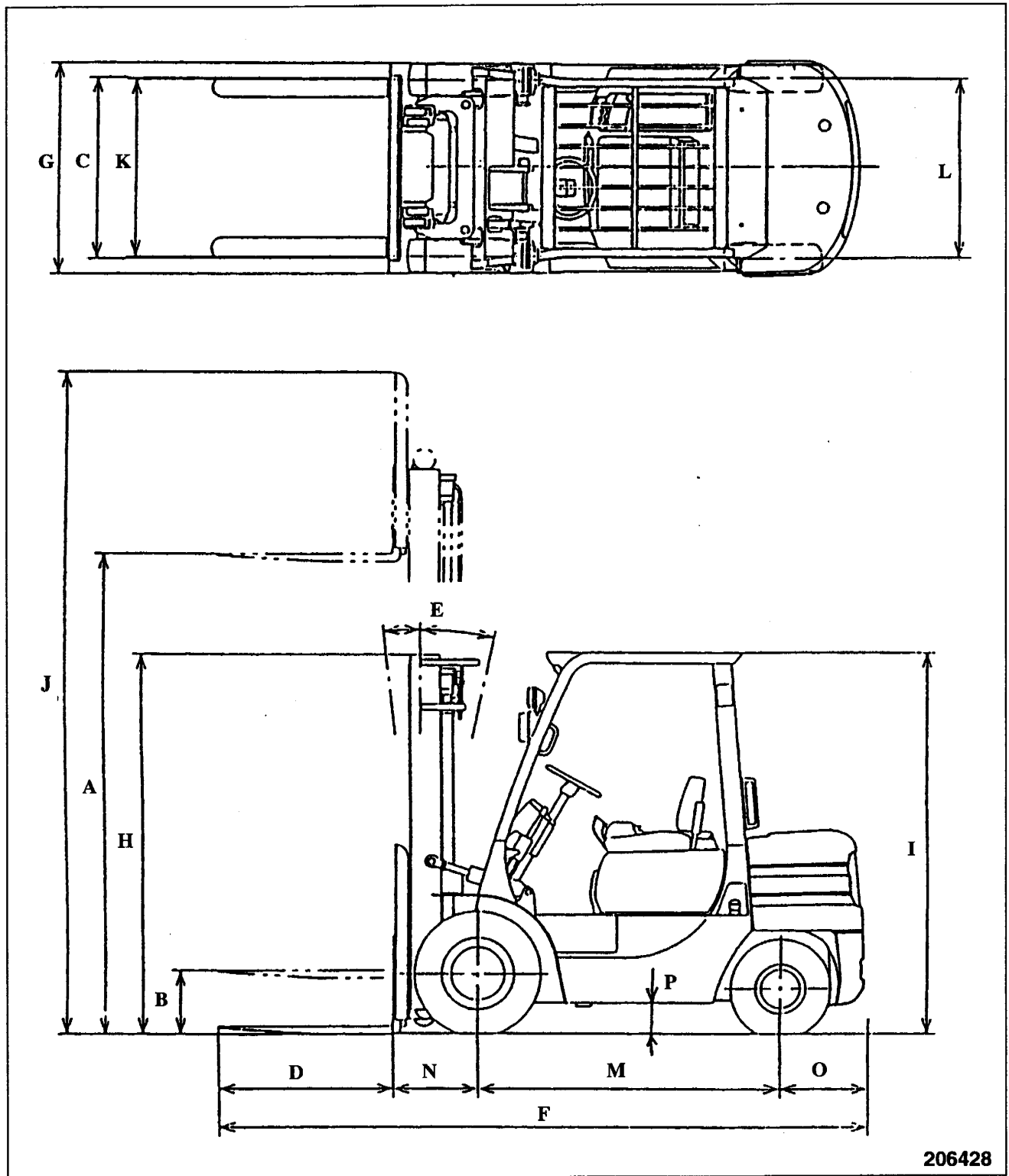

GENERAL INFORMATION

Unit: mm (in.)

Ref. No.	Truck Models		FG15K	FG18K	FG20K	FG25K	FG30K	FG35K
	Items		FD15K	FD18K	FD20K	FD25K	FD30K	FD35K
A	Maximum lift		3300 (130)		3300 (130)		3300 (130)	
B	Free lift (floor to fork top)	Simplex mast	110 (4.3)		140 (5.5)		150 (5.9)	
		Duplex mast	1120 (44.1)	1125 (44.3)	1125 (44.3)	1130 (44.5)	1160 (45.7)	1295 (51)
		Triplex mast						
C	Fork spread		220 to 920 (8.7 to 36.2)		250 to 1000 (9.8 to 39.4)		250 to 1000 (9.8 to 39.4)	
D	Fork length		1070 (42)		1070 (42)		1070 (42)	
E	Tilt angle (forward – backward)		6° – 10°		6° – 10°		6° – 10°	
F	Overall length		3280/3315 (129.1/130.5)		3515/3585 (138.4/141.1)		3775/3830 (143/150.8)	
G	Overall width (w/single tires)		1065 (41.9)		1150 (45.3)		1275/1290 (50.2/50.8)	
	Overall width (w/double tires) (outside)		1330 (52.4)		1480 (58.3)		1490 (58.7)	
H	Overall height (to top of mast lowered)		2145 (84.4)		2210 (87)		2210/2320 (87/91.3)	
I	Overall height (to top of overhead guard)		2055 (80.9)		2070 (81.5)		2095/2105 (82.5/82.9)	
J	Overall height (mast extended)	Simplex mast	4030 (158.7)		4030 (158.7)		4135 (180.1)	
		Duplex mast	4350 (171.3)		4355 (171.5)		4305 (169.5)	4355 (171.5)
		Triplex mast	5805 (228.5)		5805 (228.5)		5755 (226.6)	
K	Tread (front-single tires)		890 (35.0)		960 (37.8)		1060 (41.7)	
	Tread (front-double tires)		1025 (40.4)		1140 (44.9)		1140 (44.9)	
L	Tread (rear)		450 (17.7)		980 (38.6)		980 (38.6)	
M	Wheelbase		1390 (54.7)		1600 (63.0)		1750 (68.9)	
N	Front overhang		402 (15.8)		457 (18)		490 (19.3)	
O	Rear overhang		418/453 (16.5/17.8)		388/458 (15.3/18)		465/520 (18.3/20.5)	
P	Underclearance (at frame)		150 (5.9)		160 (6.3)		190 (7.5)	200 (7.9)



GENERAL INFORMATION

Technical Data (Standard Models)

Truck Model			FG15K	FD15K	FG18K	FD18K	FG20K	FD20K		
Designation			EF31A	EF16B	EF31A	EF16B	EF17B	EF18B		
Work performance	Capacity/load center		kg/mm (lb/in.)	1500/500 (3000/24)		1750/500 (3500/24)		2000/500 (4000/24)		
	Maximum lift height		mm (in.)	3300 (130)		3300 (130)		3300 (130)		
	Lift speed (rated load)		mm/sec	490 (96)	600 (118)	490 (96)	600 (118)	510 (100)	640 (126)	
	Lowering speed (rated load)		(fpm)	500 (98)		500 (98)		500 (98)		
	Mast tilt (forward – backward)		degree	6 – 10		6 – 10		6 – 10		
	Free lift	Simplex mast		mm (in.)	110 (4.3)		110 (4.3)		140 (5.5)	
Duplex mast		1120 (44.1)			1125 (44.3)		1125 (44.3)			
Triplex mast		1120 (44.1)			1125 (44.3)		1125 (44.3)			
Traveling performance	Travel speed	Powershift transmission models	Forward	km/h (mph)	0 to 19 (0 to 11.8)		0 to 19 (0 to 11.8)		0 to 18 (0 to 11.2)	
			Reverse		0 to 19 (0 to 11.8)		0 to 19 (0 to 11.8)		0 to 18 (0 to 11.2)	0 to 19 (0 to 11.8)
	Minimum turning radius		mm (in.)	1990 (78.3)		2020 (79.5)		2185 (86)		
	Minimum intersecting isle	Single wheels		1780 (70.1)		1800 (70.9)		1900 (74.8)		
		Double wheels	1880 (74.0)		1900 (74.8)		2020 (79.5)			
	Gradeability (reted load)	Powershift transmission models		% (tan)	30	28	28	25	28	35
Dimensions	Overall length		mm (in.)	3280 (129.1)		3315 (130.5)		3515 (138.4)		
	Overall width	Single wheels		1065 (41.9)		1065 (41.9)		1150 (45.3)		
		Double wheels		1330 (52.4)		1330 (52.4)		1480 (58.3)		
	Overall height	To top of mast lowered		2145 (84.4)		2145 (84.4)		2210 (87)		
		To top of mast extended		4030 (158.7)		4030 (158.7)		4030 (158.7)		
		To top of overhead guard		2055 (80.9)		2055 (80.9)		2070 (81.5)		
	Wheel base			1390 (54.7)		1390 (54.7)		1600 (63.0)		
	Tread	Front		Single wheels	890 (35.0)		890 (35.0)		960 (37.8)	
				Double wheels	1025 (40.4)		1025 (40.4)		1140 (44.9)	
	Rear			900 (35.4)		900 (35.4)		980 (38.6)		
	Overhang	Front		402 (15.8)		402 (15.8)		457 (18)		
		Rear		418 (16.5)		453 (17.8)		388 (15.3)		
	Underclearance (at frame)			150 (5.9)		150 (5.9)		160 (6.3)		
	Tire size and pressure	Front		Single wheels	6.50 – 10 – 10 686 (7) [100]		6.50 – 10 – 10 686 (7) [100]		7.00 – 12 – 12 686 (7) [100]	
Double wheels			4.50 – 12 – 8 686 (7) [100]		4.50 – 12 – 8 686 (7) [100]		5.00 – 15 – 8 686 (7) [100]			
Rear		5.00 – 8 – 8 686 (7) [100]		5.00 – 8 – 8 686 (7) [100]		6.00 – 9 – 10 686 (7) [100]				
Weight	Service weight		kg (lb)	2470 (5450)	2550 (5620)	2640 (5820)	2720 (6000)	3260 (7190)	3380 (7450)	
	Load distribution	Front axle		1040 (2290)	1070 (2360)	1000 (2210)	1030 (2270)	1460 (3220)	1500 (3310)	
		Rear axle		1430 (3150)	1480 (3260)	1640 (3620)	1690 (3730)	1770 (3900)	1850 (4080)	

GENERAL INFORMATION

FG25K	FD25K	FG30K	FD30K	FG35K	FD35K
EF17B	EF18B	EF13D	EF14C	EF13D	EF14C
2500/500 (5000/24)		3000/500 (6000/24)		3500/500 (7000/24)	
3300 (130)		3300 (130)		3300 (130)	
550 (108)	660 (130)	470 (93)	510 (100)	400 (79)	430 (85)
500 (98)		530 (104)		440 (87)	
6 - 10		6 - 10		6 - 10	
140 (5.5)		150 (5.9)		150 (5.9)	
1130 (44.5)		1160 (45.7)		1295 (51)	
1130 (44.5)		1160 (45.7)		1295 (51)	
0 to 18 (0 to 11.2)		0 to 19 (0 to 11.8)		0 to 19 (0 to 11.8)	0 to 18 (0 to 11.2)
0 to 18 (0 to 11.2)	0 to 19 (0 to 11.8)	0 to 19 (0 to 11.8) (0 to 11.8)		0 to 19 (0 to 11.8)	0 to 19 (0 to 11.8)
2245 (88.4)		2445 (96.2)		2485 (97.8)	
1970 (77.6)		2090 (82.3)		2120 (83.5)	
2090 (82.3)		2170 (85.4)		2190 (86.2)	
23	29	23	24	19	20
3585 (141.1)		3775 (143)		3830 (150.8)	
1150 (45.3)		1275 (50.2)		1290 (50.8)	
1480 (58.3)		1490 (58.7)		1490 (58.7)	
2210 (87)		2210 (87)		2320 (91.3)	
4030 (158.7)		4135 (162.8)		4135 (162.8)	
2070 (81.5)		2095 (82.5)		2105 (82.9)	
1600 (63.0)		1750 (68.9)		1750 (68.9)	
960 (37.8)		1060 (41.7)		1060 (41.7)	
1140 (44.9)		1140 (44.9)		1140 (44.9)	
980 (38.6)		980 (38.6)		980 (38.6)	
457 (18)		490 (19.3)		490 (19.3)	
458 (18)		465 (18.3)		520 (20.5)	
160 (6.3)		190 (7.5)		200 (7.9)	
7.00 - 12 - 12 686 (7) [100]		28 x 9 - 15 - 12 686 (7) [100]		250 - 15 - 16 834 (8.5) [120]	
5.00 - 15 - 8 686 (7) [100]		6.50 - 10 - 10 686 (7) [100]		6.50 - 10 - 10 686 (7) [100]	
6.00 - 9 - 10 686 (7) [100]		6.50 - 10 - 10 686 (7) [100]		6.50 - 10 - 12 883 (9.0) [128]	
3620 (7990)	3740 (8250)	4220 (9310)	4340 (9570)	4600 (10140)	4720 (10410)
1400 (3090)	1440 (3180)	1760 (3880)	1710 (3770)	1790 (3950)	1830 (4040)
2220 (4900)	2300 (5070)	2460 (5420)	2530 (5580)	2810 (6200)	2890 (6370)

GENERAL INFORMATION

Truck Model				FG15K	FD15K	FG18K	FD18K	FG20K	FD20K
Weight	Double wheels (without load)	Service weight		2500 (5510)	2580 (5690)	2670 (5890)	2750 (6060)	3330 (7340)	3450 (7610)
		Load distribution	Front axle	1070 (2360)	1100 (2430)	1030 (2270)	1060 (2340)	1530 (3370)	1570 (3460)
			Rear axle	1430 (3150)	1480 (3260)	1640 (3620)	1690 (3730)	1770 (3900)	1850 (4080)
kg (lb)									
Engine model				4G63	S4Q2	4G63	S4Q2	4G63	S4S
Manufacturer				Mitsubishi Motors	MHI	Mitsubishi Motors	MHI	Mitsubishi Motors	MHI
Type				Gasoline	Diesel	Gasoline	Diesel	Gasoline	Diesel
Cooling System				Water		Water		Water	
No. of cylinders - arrangement				4 -in-line		4 -in-line		4 -in-line	
No. of strokes				4		4		4	
Types of combustion chambers				Semi-spherical	Swirl	Semi-spherical	Swirl	Semi-spherical	Swirl
Valve arrangement				OHC	OHV	OHC	OHV	OHC	OHV
Type of cylinder liners				Integral with cylinder block	Dry	Integral with cylinder block	Dry	Integral with cylinder block	Dry
Cylinder bore × stroke			mm (in.)	85 × 88 (3.346 × 3.465)	88 × 103 (3.465 × 4.055)	85 × 88 (3.346 × 3.465)	88 × 103 (3.465 × 4.055)	85 × 88 (3.346 × 3.465)	94 × 120 (3.701 × 4.724)
Displacement			cc (cu. in.)	1997 (121.8)	2505 (152.8)	1997 (121.8)	2505 (152.8)	1997 (121.8)	3331 (203.2)
Compression ratio				8.5 : 1	22 : 1	8.5 : 1	22 : 1	8.5 : 1	22 : 1
Rated output			PS/rpm	42/2400	40/2200	42/2400	40/2200	42/2400	60/2200
Maximum torque			N·m (kgf·m) [lbf·ft]/rpm	134 (13.7) [99]/1600	136 (13.9) [101]/1600	134 (13.7) [99]/1600	136 (13.9) [101]/1600	134 (13.7) [99]/1600	201 (20.5) [148]/1400
Dimensions (length × width × height)			mm (in.)	653 × 604 × 759 (25.7 × 23.8 × 29.9)	686 × 493 × 623 (27.0 × 19.4 × 24.5)	653 × 604 × 759 (25.7 × 23.8 × 29.9)	686 × 493 × 623 (27.0 × 19.4 × 24.5)	653 × 604 × 759 (25.7 × 23.8 × 29.9)	647 × 552 × 712 (25.5 × 21.7 × 28)
Weight (service)			kg (lb)	150 (330)	180 (397)	150 (330)	180 (397)	150 (330)	260 (570)
Location				Rear		Rear		Rear	
Intake valves		Open BTDC	degree	12	30	12	30	12	30
		Close ABDC		40	50	40	50	40	50
Exhaust valves		Open BBDC		54	74	54	74	54	74
		Close ATDC		6	30	6	30	6	30
Valve clearance		Intake valves	mm (in.)	0.00 (hot)	0.25 (0.0098) (cold)	0.00 (hot)	0.25 (0.0098) (cold)	0.00 (hot)	0.25 (0.0098) (cold)
		Exhaust valves		0.00 (hot)	0.25 (0.0098) (cold)	0.00 (hot)	0.25 (0.0098) (cold)	0.00 (hot)	0.25 (0.0098) (cold)
Ignition				Spark	Compression	Spark	Compression	Spark	Compression
Firing order				1 - 3 - 4 - 2		1 - 3 - 4 - 2		1 - 3 - 4 - 2	
Ignition timing BTDC			degree/rpm	6/650	-	6/650	-	6/650	-
Injection timing BTDC			degree	-	18	-	18	-	20
Fuel tank rated capacity			liter (U.S. gal)	53 (14)		53 (14)		76 (20)	

GENERAL INFORMATION

FG25K	FD25K	FG30K	FD35K	FG35K	FD35K
3690 (8140)	3810 (8400)	4240 (9350)	4360 (9610)	4620 (10190)	4740 (10450)
1470 (3240)	1520 (3550)	1780 (3920)	1830 (4040)	1810 (3990)	1850 (4080)
2220 (4900)	2290 (5050)	2460 (5420)	2530 (5580)	2810 (6200)	2890 (6870)
4G63	S4S	4G64	S4S	4G64	S4S
Mitsubishi Motors	MHI	Mitsubishi Motors	MHI	Mitsubishi Motors	MHI
Gasoline	Diesel	Gasoline	Diesel	Gasoline	Diesel
Water		Water		Water	
4 -in-line		4 -in-line		4 -in-line	
4		4		4	
Semi- spherical	Swirl	Semi- spherical	Swirl	Semi- spherical	Swirl
OHC	OHV	OHC	OHV	OHC	OHV
Integral with cylinder block	Dry	Integral with cylinder block	Dry	Integral with cylinder block	Dry
85 × 88 (3.346 × 3.465)	94 × 120 (3.701 × 4.724)	86.5 × 100 (3.406 × 3.937)	94 × 120 (3.701 × 4.724)	86.5 × 100 (3.406 × 3.937)	94 × 120 (3.701 × 4.724)
1997 (121.8)	3331 (203.2)	2350 (143.4)	3331 (203.2)	2350 (143.4)	3331 (203.2)
8.5 : 1	22 : 1	8.6 : 1	22 : 1	8.6 : 1	22 : 1
42/2400	60/2200	50/2400	60/2200	50/2400	60/2200
134 (13.7) [99]/1600	201 (20.5) [148]/1400	167 (17) [123]/1600	201 (20.5) [148]/1400	167 (17) [123]/1600	201 (20.5) [148]/1400
653 × 604 × 759 (25.7 × 23.8 × 29.9)	647 × 552 × 712 (25.5 × 21.7 × 28)	653 × 604 × 759 (25.7 × 23.8 × 29.9)	647 × 552 × 712 (25.5 × 21.7 × 28)	653 × 604 × 759 (25.7 × 23.8 × 29.9)	647 × 552 × 712 (25.5 × 21.7 × 28)
150 (330)	260 (570)	150 (330)	260 (570)	150 (330)	260 (570)
Rear		Rear		Rear	
12	30	12	30	12	30
40	50	40	50	40	50
54	74	54	74	54	74
6	30	6	30	6	30
0.00 (hot)	0.25 (0.0098) (cold)	0.00 (hot)	0.25 (0.0098) (cold)	0.00 (hot)	0.25 (0.0098) (cold)
0.00 (hot)	0.25 (0.0098) (cold)	0.00 (hot)	0.25 (0.0098) (cold)	0.00 (hot)	0.25 (0.0098) (cold)
Spark	Compression	Spark	Compression	Spark	Compression
1 - 3 - 4 - 2		1 - 3 - 4 - 2		1 - 3 - 4 - 2	
6/650	-	6/650	-	6/650	-
-	20	-	20	-	20
76 (20)		76 (20)		76 (20)	

GENERAL INFORMATION

Truck Model			FG15K	FD15K	FG18K	FD18K	FG20K	FD20K	
Ignition system (gasoline models)	Ignition coil	Type	With external resistor	-	With external resistor	-	With external resistor	-	
		Manufacturer	Mitsubishi Electric	-	Mitsubishi Electric	-	Mitsubishi Electric	-	
	Distributor	Type	Non-contact point type (C.E.I.)	-	Non-contact point type (C.E.I.)	-	Non-contact point type (C.E.I.)	-	
		Manufacturer	Mitsubishi Electric	-	Mitsubishi Electric	-	Mitsubishi Electric	-	
		Spark advancer	Centrifugal pneumatic type	-	Centrifugal pneumatic type	-	Centrifugal pneumatic type	-	
	Spark plugs	Type	W14EX-U	-	W14EX-U	-	W14EX-U	-	
		Manufacturer	Nippon Denso	-	Nippon Denso	-	Nippon Denso	-	
		Size	mm (in.)	14 × 1.25 (0.55 × 0.049)	-	14 × 1.25 (0.55 × 0.049)	-	14 × 1.25 (0.55 × 0.049)	-
		Gap		0.7 to 0.8 (0.028 to 0.031)	-	0.7 to 0.8 (0.028 to 0.031)	-	0.7 to 0.8 (0.028 to 0.031)	-
	Fuel system (gasoline models)	Carburetor	Type	Down-draft type	-	Down-draft type	-	Down-draft type	-
Manufacturer			Mikuni Kogyo	-	Mikuni Kogyo	-	Mikuni Kogyo	-	
Governor		Type	Pneumatic type	-	Pneumatic type	-	Pneumatic type	-	
		Manufacturer	Mikuni Kogyo	-	Mikuni Kogyo	-	Mikuni Kogyo	-	
Fuel pump		Type	Diaphragm type	-	Diaphragm type	-	Diaphragm type	-	
		Manufacturer	Kyosan Electric	-	Kyosan Electric	-	Kyosan Electric	-	
Air cleaner		Type × number	Cyclone-paper element × 1	-	Cyclone-paper element × 1	-	Cyclone-paper element × 1	-	
		Manufacturer	Nippon Rokaki	-	Nippon Rokaki	-	Nippon Rokaki	-	
Fuel system (diesel models)	Fuel injection pump	Type	-	Distributor type (DPK)	-	Distributor type (DPK)	-	Distributor type (DPK)	
		Manufacturer	-	Mikuni Precision	-	Mikuni Precision	-	Mikuni Precision	
		Plunger diam.	mm (in.)	-	6.5 (0.256)	-	6.5 (0.256)	-	7.0 (0.275)
		Cam lift (one side)		-	1.5 (0.059)	-	1.5 (0.059)	-	1.5 (0.059)
	Fuel injection nozzle	Type	-	Throttle type	-	Throttle type	-	Throttle type	
		Spray holes, diam. × number	mm (in.)	-	1.00 (0.0394) × 1	-	1.00 (0.0394) × 1	-	1.00 (0.0394) × 1
		Injection pressure	kPa (kgf/cm <sup>2</sup> ) [psi]	-	11768 <sup>+981</sup> <sub>0</sub> (120 <sup>+10</sup> <sub>0</sub> ) [1706 <sup>+142</sup> <sub>0</sub> ]	-	11768 <sup>+981</sup> <sub>0</sub> (120 <sup>+10</sup> <sub>0</sub> ) [1706 <sup>+142</sup> <sub>0</sub> ]	-	13729 <sup>+1079</sup> <sub>0</sub> (140 <sup>+11</sup> <sub>5</sub> ) [1990 <sup>+156</sup> <sub>71</sub> ]

GENERAL INFORMATION

FG25K	FD25K	FG30K	FD30K	FG35K	FD35K
With external resistor	-	With external resistor	-	With external resistor	-
Mitsubishi Electric	-	Mitsubishi Electric	-	Mitsubishi Electric	-
Non-contact point type (C.E.I.)	-	Non-contact point type (C.E.I.)	-	Non-contact point type (C.E.I.)	-
Mitsubishi Electric	-	Mitsubishi Electric	-	Mitsubishi Electric	-
Centrifugal pneumatic type	-	Centrifugal pneumatic type	-	Centrifugal pneumatic type	-
W14EX-U	-	W14EX-U	-	W14EX-U	-
Nippon Denso	-	Nippon Denso	-	Nippon Denso	-
14 × 1.25 (0.55 × 0.049)	-	14 × 1.25 (0.55 × 0.049)	-	14 × 1.25 (0.55 × 0.049)	-
0.7 to 0.8 (0.028 to 0.031)	-	0.7 to 0.8 (0.028 to 0.031)	-	0.7 to 0.8 (0.028 to 0.031)	-
Down-draft type	-	Down-draft type	-	Down-draft type	-
Mikuni Kogyo	-	Mikuni Kogyo	-	Mikuni Kogyo	-
Pneumatic type	-	Pneumatic type	-	Pneumatic type	-
Mikuni Kogyo	-	Mikuni Kogyo	-	Mikuni Kogyo	-
Diaphragm type	-	Diaphragm type	-	Diaphragm type	-
Kyosan Electric	-	Kyosan Electric	-	Kyosan Electric	-
Cyclone-paper element × 1	-	Cyclone-paper element × 1	-	Cyclone-paper element × 1	-
Nippon Rokaki	-	Nippon Rokaki	-	Nippon Rokaki	-
-	Distributor type (DPK)	-	Distributor type (DPK)	-	Distributor type (DPK)
-	Mikuni Precision	-	Mikuni Precision	-	Mikuni Precision
-	7.0 (0.256)	-	7.0 (0.256)	-	7.0 (0.275)
-	1.5 (0.059)	-	1.5 (0.059)	-	1.5 (0.059)
-	Throttle type	-	Throttle type	-	Throttle type
-	1.00 (0.0394) × 1	-	1.00 (0.0394) × 1	-	1.00 (0.0394) × 1
-	13729 <sup>+1 079</sup> <sub>+ 490</sub> (140 <sup>+11</sup> <sub>+ 5</sub> ) [1990 <sup>+156</sup> <sub>+ 71</sub> ]	-	13729 <sup>+1 079</sup> <sub>+ 490</sub> (140 <sup>+11</sup> <sub>+ 5</sub> ) [1990 <sup>+156</sup> <sub>+ 71</sub> ]	-	13729 <sup>+1 079</sup> <sub>+ 490</sub> (140 <sup>+11</sup> <sub>+ 5</sub> ) [1990 <sup>+156</sup> <sub>+ 71</sub> ]

GENERAL INFORMATION

Truck Model			FG15K	FD15K	FG18K	FD18K	FG20K	FD20K	
Air and fuel (diesel model)	Heater plugs	Type	-	Sheathed type	-	Sheathed type	-	Sheathed type	
		Voltage-current	V - A	-	22 - 5.4	-	22 - 5.4	-	22 - 5.4
	Fuel feed pump	Type	-	Vane type	-	Vane type	-	Vane type	
		Manufacturer	-	Lusus CAV	-	Lusus CAV	-	Lusus CAV	
	Air cleaner	Type x number	-	Cyclone-paper element x 1	-	Cyclone-paper element x 1	-	Cyclone-paper element x 1	
		Manufacturer	-	Nippon Rokaki	-	Nippon Rokaki	-	Nippon Rokaki	
Lubrication system	Type		Pressure feed type		Pressure feed type		Pressure feed type		
	Oil pump		Trochoid type		Trochoid type		Trochoid type		
	Oil filter		Paper-element		Paper-element		Paper-element		
	Refill capacities	Oil pan	liter (U.S.gal)	4.5 (1.2)	6.0 (2.4)	4.5 (1.2)	6.0 (2.4)	4.5 (1.2)	9.0 (2.4)
		Oil filter		0.3 (0.1)	0.7 (0.3)	0.3 (0.1)	0.7 (0.3)	0.3 (0.1)	1.0 (0.3)
Total		4.8 (1.3)		6.7 (1.8)	4.8 (1.3)	6.7 (1.8)	4.8 (1.3)	10.0 (2.7)	
Cooling system	Type		Forced circulation		Forced circulation		Forced circulation		
	Radiator		Corrugated fin (pressure) type		Corrugated fin (pressure) type		Corrugated fin (pressure) type		
	Refill capacity	liter (U.S.gal)	7.65 (2.0)	8.55 (2.3)	7.65 (2.0)	8.55 (2.3)	8.9 (2.3)	9.6 (2.5)	
	Water pump		Centrifugal type		Centrifugal type		Centrifugal type		
	Thermostat		Wax type		Wax type		Wax type		
Battery	Voltage	V	12	12	12	12	12	12	
	Capacity	Ah	30	65	30	65	40	80	
Alternator and regulator	Alternator type		3-phase AC		3-phase AC		3-phase AC		
	Manufacturer		Mitsubishi Electric		Mitsubishi Electric		Mitsubishi Electric		
	Capacity	V - A	12 - 50	12 - 50	12 - 50	12 - 50	12 - 50	12 - 50	
	Regulator		Built-in IC type		Built-in IC type		Built-in IC type		
Starter	Type		Lever-shift type		Lever-shift type		Lever-shift type		
	Manufacturer		Mitsubishi Electric		Mitsubishi Electric		Mitsubishi Electric		
	Voltage - output	V - kW	12 - 1.2	12 - 2.2	12 - 1.2	12 - 2.2	12 - 1.2	12 - 2.2	
Power train	Clutch	Type	Dry, single-disc type (Op. wet type)		Dry, single-disc type (Op. wet type)		Dry, single-disc type (Op. wet type)		
		Size (OD x ID)	mm (in.)	275 x 180 (10.8 x 7.1)	275 x 175 (10.8 x 6.9)	275 x 180 (10.8 x 7.1)	275 x 175 (10.8 x 6.9)	275 x 180 (10.8 x 7.1)	275 x 175 (10.8 x 6.9)
		Material		DR-8	Special	DR-8	Special	DR-8	Special
	Clutch booster (wet)	Type		Master VAC		Master VAC		Master VAC	
		Master cylinder ID	mm (in.)	15.87 (0.6248)		15.87 (0.6248)		15.87 (0.6248)	
		Release cylinder ID		19.05 (0.7500)		19.05 (0.7500)		19.05 (0.7500)	
	Torque converter	Type		3-element, 1-stage, 2-phase		3-element, 1-stage, 2-phase		3-element, 1-stage, 2-phase	
		Manufacturer's type		Daikin 66H7		Daikin 66H7		Daikin 66H8	
Stall torque ratio			2.8		2.8		3.0		

GENERAL INFORMATION

FG25K	FD25K	FG30K	FD30K	FG35K	FD35K
–	Sheathed type	–	Sheathed type	–	Sheathed type
–	22 – 5.4	–	22 – 5.4	–	22 – 5.4
–	Vane type	–	Vane type	–	Vane type
–	Lusus CAV	–	Lusus CAV	–	Lusus CAV
–	Cyclone-paper element × 1	–	Cyclone-paper element × 1	–	Cyclone-paper element × 1
–	Nippon Rokaki	–	Nippon Rokaki	–	Nippon Rokaki
Pressure feed type		Pressure feed type		Pressure feed type	
Trochoid type		Trochoid type		Trochoid type	
Paper-element		Paper-element		Paper-element	
4.5 (1.2)	9.0 (2.4)	4.5 (1.2)	9.0 (2.4)	4.5 (1.2)	9.0 (2.4)
0.3 (0.1)	1.0 (0.3)	0.3 (0.1)	1.0 (0.3)	0.3 (0.1)	1.0 (0.3)
4.8 (1.3)	10.0 (2.7)	4.8 (1.3)	10.0 (2.7)	4.8 (1.3)	10.0 (2.7)
Forced circulation		Forced circulation		Forced circulation	
Corrugated fin (pressure) type		Corrugated fin (pressure) type		Corrugated fin (pressure) type	
8.9 (2.3)	9.6 (2.5)	8.9 (2.3)	9.6 (2.5)	8.9 (2.3)	9.6 (2.5)
Centrifugal type		Centrifugal type		Centrifugal type	
Wax type		Wax type		Wax type	
12	12	12	12	12	12
40	80	40	80	40	80
3-phase AC		3-phase AC		3-phase AC	
Mitsubishi Electric		Mitsubishi Electric		Mitsubishi Electric	
12 – 50	12 – 50	12 – 50	12 – 50	12 – 50	12 – 50
Built-in IC type		Built-in IC type		Built-in IC type	
Lever-shift type		Lever-shift type		Lever-shift type	
Mitsubishi Electric		Mitsubishi Electric		Mitsubishi Electric	
12 – 1.2	12 – 2.2	12 – 1.2	12 – 2.2	12 – 1.2	12 – 2.2
Dry, single-disc type (Op. wet type)		Dry, single-disc type (Op. wet type)		Dry, single-disc type (Op. wet type)	
275 × 180 (10.8 × 7.1)	275 × 175 (10.8 × 6.9)	275 × 180 (10.8 × 7.1)	275 × 175 (10.8 × 6.9)	275 × 180 (10.8 × 7.1)	275 × 175 (10.8 × 6.9)
DR-8	Special	DR-8	Special	DR-8	Special
Master VAC		Master VAC		Master VAC	
15.87 (0.6248)		15.87 (0.6248)		15.87 (0.6248)	
19.05 (0.7500)		19.05 (0.7500)		19.05 (0.7500)	
3-element, 1-stage, 2-phase		3-element, 1-stage, 2-phase		3-element, 1-stage, 2-phase	
Daikin 66H8		Daikin 66H8		Daikin 66H8	
3.0		3.0		3.0	



# GENERAL INFORMATION

Truck Model				FG15K	FD15K	FG18K	FD18K	FG20K	FD20K
Power train	Transmission	Control and shift		Hydraulic column shift		Hydraulic column shift		Hydraulic column shift	
		Power-shaft	Ratios	Forward	2.195	2.195	2.195	2.195	
				Reverse	2.258	2.258	2.258		
	Transfer	Type of gears		Spur		Spur		Spur	
		Gear ratio	Manual transmission	1.257	1.167	1.257	1.167	1.257	1.135
			Powershift transmission	1.394	1.257	1.394	1.257	1.394	1.167
	Reduction gear	Type of gears		Spiral bevel		Spiral bevel		Spiral bevel	
		Ratio		4.571		4.571		5.667	
	Differential	Axle housing		Banjo		Banjo		Banjo	
		Type of gears-number	Gears	Straight bevel - 2		Straight bevel - 2		Straight bevel - 2	
Pinions			Straight bevel - 2		Straight bevel - 2		Straight bevel - 2		
Steering system	Type			Full Hydrostatic power steering		Full Hydrostatic power steering		Full Hydrostatic power steering	
	Turning angle	Inside	degree	82°		82°		83°	
		Outside		55°		55°		56°	
	Steering wheel diameter		mm (in.)	330 (13)		330 (13)		330 (13)	
	Steering cylinder	Steering cylinder ID × rod OD	mm (in.)	63 × 40 (2.48 × 1.575)		63 × 40 (2.48 × 1.575)		75 × 50 (2.953 × 1.068)	
		Effective stroke		215 (8.46)		215 (8.46)		210 (8.27)	
		Relief pressure	kPa (kgf/cm <sup>2</sup> )[psi]	7.355 (75) [1066]		7.355 (75) [1066]		7.355 (75) [1066]	
Flow rate		liter (cu. in.)/min	10.5 ± 0.5 (640.1 ± 30.5)		10.5 ± 0.5 (640.1 ± 30.5)		10.5 ± 0.5 (640.1 ± 30.5)		
Traveling system	Front axle			Full-floating tubular type		Full-floating tubular type		Full-floating tubular type	
	Rear axle			Elliott type		Elliott type		Elliott type	
	Mounting	Front wheels		Fixed type		Fixed type		Fixed type	
		Rear wheels		Center-pivot type		Center-pivot type		Center-pivot type	
	Wheel alignment	Toe-in	mm (in.)	0		0		0	
		Camber	degree	1		1		1	
		Caster		0		0		0	
Kingpin inclination		0		0		0			
Brake system	Service brake	Type		Hydraulic, duo-servo, mounted on front wheels		Hydraulic, duo-servo, mounted on front wheels		Hydraulic, duo-servo, mounted on front wheels	
		Drum diameter	mm (in.)	254 (10.00)		254 (10.00)		310 (12.20)	
		Lining (lgth × width × thk × number)		274.2 × 48.5 × 4.78 × 2 (10.80 × 1.91 × 0.19 × 2)		274.2 × 48.5 × 4.78 × 2 (10.80 × 1.91 × 0.19 × 2)		344 × 60.0 × 6.4 × 2 (13.54 × 2.36 × 0.24 × 2)	
		Master cylinder ID		19.05 (0.7500)		19.05 (0.7500)		19.05 (0.7500)	
	Wheel cylinder ID	22.22 (0.8748)		22.22 (0.8748)		28.58 (1.1252)			
Parking brake	Type		Mechanical, mounted on front wheels		Mechanical, mounted on front wheels		Mechanical, mounted on front wheels		
	Drum diameter	mm (in.)	254 (10)		254 (10)		310 (12.2)		

GENERAL INFORMATION

FG25K	FD25K	FG30K	FD30K	FG35K	FD35K
Hydraulic column shift		Hydraulic column shift		Hydraulic column shift	
2.195		2.195		2.195	
2.258		2.258		2.258	
Spur		Spur		Spur	
1.257	1.135	1.394	1.167	1.394	1.167
1.394	1.167	1.394	1.257	1.394	1.257
Spiral bevel		Spiral bevel		Spiral bevel	
5.667		5.667		5.667	
Banjo		Banjo		Banjo	
Straight bevel - 2		Straight bevel - 2		Straight bevel - 2	
Straight bevel - 2		Straight bevel - 2		Straight bevel - 2	
Full Hydrostatic power steering		Full Hydrostatic power steering		Full Hydrostatic power steering	
83°		83°		83°	
56°		56°		56°	
330 (13)		330 (13)		330 (13)	
75 × 50 (2.953 × 1.068)		75 × 50 (2.953 × 1.068)		75 × 50 (2.953 × 1.068)	
210 (8.27)		210 (8.27)		210 (8.27)	
7.355 (75) [1066]		7.355 (75) [1066]		7.355 (75) [1066]	
10.5 ± 0.5 (640.1 ± 30.5)		10.5 ± 0.5 (640.1 ± 30.5)		10.5 ± 0.5 (640.1 ± 30.5)	12 ± 1.0 (732.3 ± 61.0)
Full-floating tubular type		Full-floating tubular type		Full-floating tubular type	
Elliott type		Elliott type		Elliott type	
Fixed type		Fixed type		Fixed type	
Center-pivot type		Center-pivot type		Center-pivot type	
0		0		0	
1		1		1	
0		0		0	
0		0		0	
Hydraulic, duo-servo, mounted on front wheels		Hydraulic, duo-servo, mounted on front wheels		Hydraulic, duo-servo, mounted on front wheels	
310 (12.20)		310 (12.20)		310 (12.20)	
344 × 60.0 × 6.0 × 2 (13.54 × 2.36 × 0.24 × 2)		344 × 60.0 × 6.0 × 2 (13.54 × 2.36 × 0.24 × 2)		344 × 60.0 × 6.0 × 2 (13.54 × 2.36 × 0.24 × 2)	
19.05 (0.7500)		19.05 (0.7500)		19.05 (0.7500)	
28.58 (1.1252)		28.58 (1.1252)		28.58 (1.1252)	
Mechanical, mounted on front wheels		Mechanical, mounted on front wheels		Mechanical, mounted on front wheels	
310 (12.2)		310 (12.2)		310 (12.2)	

GENERAL INFORMATION

Truck Model			FG15K	FD15K	FG18K	FD18K	FG20K	FD20K	
Body-frame			Unitized type		Unitized type		Unitized type		
Hydraulic system	Hydraulic pump	Type	Gear		Gear		Gear		
		Manufacturer's type	KRP4	KFP3240	KRP4	KFP3240	KRP4	KFP3240	
		Rated displacement	liter (cu. in.)	58.8 (3588) /2400 rpm	66.0 (4028) /2200 rpm	58.8 (3588) /2400 rpm	66.0 (4028) /2200 rpm	72 (4394) /2400 rpm	88 (5370) /2200 rpm
		Drive line	Universal joint		Universal joint		Universal joint		
	Control valve	Model	KVSF65		KVSF65		KVSF65		
		Relief pressure	kPa (kgf/cm <sup>2</sup> ) [psi]	18142 <sup>+490</sup> / <sub>0</sub> (185 <sup>+5</sup> / <sub>0</sub> ) [2331 <sup>+71</sup> / <sub>0</sub> ]		18142 <sup>+490</sup> / <sub>0</sub> (185 <sup>+5</sup> / <sub>0</sub> ) [2631 <sup>+71</sup> / <sub>0</sub> ]		18142 <sup>+490</sup> / <sub>0</sub> (185 <sup>+5</sup> / <sub>0</sub> ) [2631 <sup>+71</sup> / <sub>0</sub> ]	
	Hydraulic (pressure) transducer	Type	KA11-S07		KA11-S07		KA11-S07		
		Range of pressure	MPa (kgf/cm <sup>2</sup> ) [psi]	0 to 21 (0 to 210) [0 to 14.8]		0 to 21 (0 to 210) [0 to 14.8]		0 to 21 (0 to 210) [0 to 14.8]	
	Lift cylinders (Simplex mast)	ID	mm (in.)	45 (1.77)		45 (1.77)		50 (1.97)	
		Stroke		1500 (59)		1500 (59)		1500 (59)	
	No.1 Lift cylinder (Duplex mast)	ID		70 (2.76)		70 (2.76)		75 (2.95)	
		Stroke		850 (33.5)		850 (33.5)		850 (33.5)	
	No.2 Lift cylinder (Duplex mast)	ID		45 (1.77)		45 (1.77)		45 (1.77)	
		Stroke		1595 (62.8)		1595 (62.8)		1600 (63)	
	No.1 Lift cylinder (Triplex mast)	ID		70 (2.76)		70 (2.76)		75 (2.95)	
Stroke		850 (33.5)			850 (33.5)		850 (33.5)		
No.2 Lift cylinder (Triplex mast)	ID	45 (1.77)			45 (1.77)		50 (1.97)		
	Stroke	1525 (60)			1525 (60)		1525 (60)		
Tilt cylinders	ID	63 (2.48)			63 (2.48)		70 (2.76)		
	Stroke	125 (4.92)			125 (4.92)		141 (5.55)		
Hydraulic tank capacity (approx.)	N level	liter (U.S. gal)		27.8 (7.3)		27.8 (7.3)		40.1 (10.6)	
	H level			30.9 (8.2)		30.9 (8.2)		45.1 (11.9)	
Mast and forks	Mast			Roller type CL		Roller type CL		Roller type CL	
	Mast dimensions (Flange inside width × Flange thk (Fr.) × Flange thk (Re.) × Web thk)	Outer	mm (in.)	100 × 17 × 19 × 11 (3.94 × 0.67 × 0.75 × 0.43)		100 × 17 × 19 × 11 (3.94 × 0.67 × 0.75 × 0.43)		115 × 22 × 27 × 12 (4.53 × 0.87 × 1.06 × 0.47)	
		Middle		100 × 17 × 19 × 10 (3.94 × 0.67 × 0.75 × 0.39)		100 × 17 × 19 × 10 (3.94 × 0.67 × 0.75 × 0.39)		115 × 22 × 23 × 11 (4.53 × 0.87 × 0.91 × 0.43)	
		Inner		100 × 17 × 19 × 10 (3.94 × 0.67 × 0.75 × 0.39)		100 × 17 × 19 × 10 (3.94 × 0.67 × 0.75 × 0.39)		115 × 22 × 23 × 11 (4.53 × 0.87 × 0.91 × 0.43)	
	Main rollers	Type	#6308 ball bearing		#6308 ball bearing		#6309 ball bearing		
		Diam × width	mm (in.)	100 × 27 (3.94 × 1.06)		100 × 27 (3.94 × 1.06)		115 × 30 (4.53 × 1.18)	
	Side rollers	Type	Lubricating type needle roller bearing		Lubricating type needle roller bearing		Lubricating type needle roller bearing		
		Diam × width	mm (in.)	42 × 36 (1.65 × 1.42)		42 × 36 (1.65 × 1.42)		42 × 36 (1.65 × 1.42)	
	Lift chains			BL534		BL534		BL634	
	Fork (lgth × width × thk)		mm (in.)	1070 × 100 × 40 (42.1 × 3.9 × 1.6)		1070 × 100 × 40 (42.1 × 3.9 × 1.6)		1070 × 100 × 45 (42.1 × 3.9 × 1.8)	
Fork spacing (out to out)		200 to 820 (7.9 to 32.3)			250 to 920 (9.8 to 36.2)		250 to 920 (9.8 to 36.2)		

GENERAL INFORMATION

FG25K	FD25K	FG30K	FD30K	FG35K	FD35K
Unitized type		Unitized type		Unitized type	
Gear		Gear		Gear	
KRP4	KFP3240	KRP4	KFP3240	KRP4	KFP3240
72.0 (4394) /2400 rpm	88.0 (5370) /2200 rpm	79.9 (4876) /2400 rpm	85.0 (5187) /2200 rpm	79.9 (4876) /2400 rpm	85.0 (5187) /2200 rpm
Universal joint		Universal joint		Universal joint	
KVSF65		KVSF65		KVSF65	
18142 <sup>+490</sup> <sub>0</sub> (185 <sup>+5</sup> <sub>0</sub> ) [2631 <sup>+71</sup> <sub>0</sub> ]		18142 <sup>+490</sup> <sub>0</sub> (185 <sup>+5</sup> <sub>0</sub> ) [2631 <sup>+71</sup> <sub>0</sub> ]		18142 <sup>+490</sup> <sub>0</sub> (185 <sup>+5</sup> <sub>0</sub> ) [2631 <sup>+71</sup> <sub>0</sub> ]	
KA11-S07		KA11-S07		KA11-S07	
0 to 21 (0 to 210) [0 to 14.8]		0 to 21 (0 to 210) [0 to 14.8]		0 to 21 (0 to 210) [0 to 14.8]	
50 (1.97)		55.2 (2.17)		60 (2.56)	
1500 (59)		1500 (59)		1500 (59)	
75 (2.95)		85.2 (3.35)		90 (3.54)	
850 (33.5)		835 (32.9)		850 (33.5)	
45 (1.77)		50 (1.97)		55 (2.16)	
1600 (63)		1580 (62.2)		1600 (63)	
75 (2.95)		85.2 (3.35)		90 (3.54)	
850 (33.5)		835 (32.9)		850 (33.5)	
50 (1.97)		55.2 (2.17)		60 (2.36)	
1525 (60)		1515 (59.6)		1500 (59.1)	
70 (2.76)		80 (3.15)		80 (3.15)	
141 (5.55)		141 (5.55)		141 (5.55)	
40.1 (10.6)		40.1 (10.6)		40.1 (10.6)	
45.1 (11.9)		45.1 (11.9)		45.1 (11.9)	
Roller type CL		Roller type CL		Roller type CL	
115 × 22 × 27 × 12 (4.53 × 0.87 × 1.06 × 0.47)		115 × 22 × 27 × 12 (4.53 × 0.87 × 1.06 × 0.47)		115 × 22 × 27 × 12 (4.53 × 0.87 × 1.06 × 0.47)	
115 × 22 × 23 × 11 (4.53 × 0.87 × 0.91 × 0.43)		115 × 22 × 23 × 11 (4.53 × 0.87 × 0.91 × 0.43)		115 × 22 × 23 × 11 (4.53 × 0.87 × 0.91 × 0.43)	
115 × 22 × 23 × 11 (4.53 × 0.87 × 0.91 × 0.43)		115 × 22 × 23 × 11 (4.53 × 0.87 × 0.91 × 0.43)		115 × 22 × 23 × 11 (4.53 × 0.87 × 0.91 × 0.43)	
#6309 ball bearing		#6309 ball bearing		#6309 ball bearing	
115 × 30 (4.53 × 1.18)		115 × 30 (4.53 × 1.18)		115 × 30 (4.53 × 1.18)	
Lubricating type needle roller bearing		Lubricating type needle roller bearing		Lubricating type needle roller bearing	
42 × 36 (1.65 × 1.42)		42 × 36 (1.65 × 1.42)		42 × 36 (1.65 × 1.42)	
BL634		BL834		BL834	
1070 × 100 × 45 (42 × 3.9 × 1.8)		1070 × 125 × 45 (42 × 5 × 1.8)		1070 × 125 × 50 (42 × 5 × 1.97)	
250 to 920 (9.8 to 32.3)		250 to 960 (9.8 to 37.8)		250 to 960 (9.8 to 37.8)	

## COOLING SYSTEM

Description .....	2 - 1
Removal and Installation .....	2 - 2
Fan Belt Removal .....	2 - 2
Inspection and Adjustment .....	2 - 3
Fan Belt Inspection .....	2 - 3
Fan Belt Adjustment .....	2 - 3

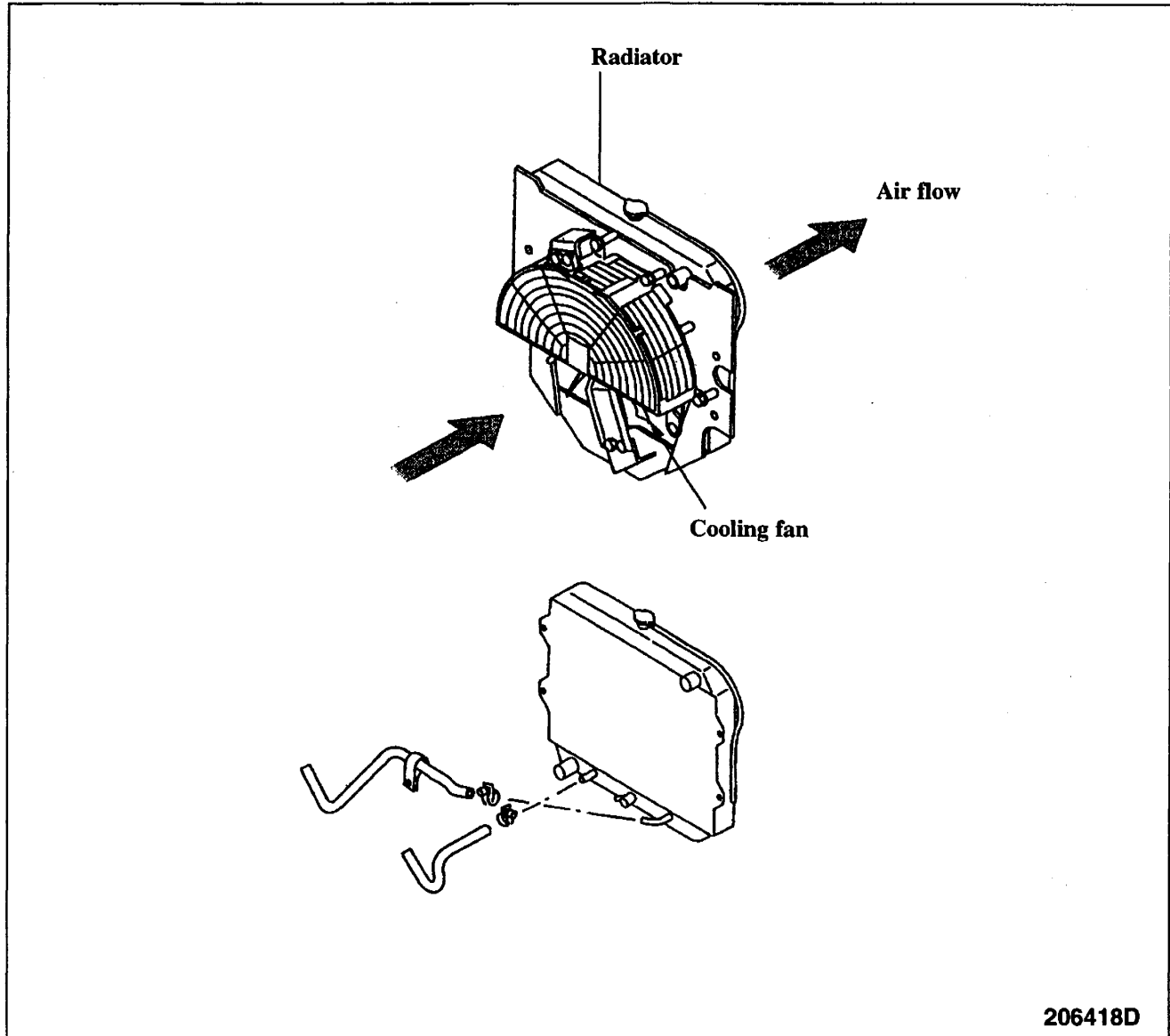
**Description**

206418D

**Powershift Transmission models**

The cooling fan is installed inside with the radiator (in the engine compartment). This helps minimize radiator core clogging and retain high cooling efficiency even in continuous operation for hours (pusher for system). In the powershift transmission models, the radiator lower tank has a built-in transmission oil cooler.

## COOLING SYSTEM

### Removal and Installation

#### Fan Belt Removal

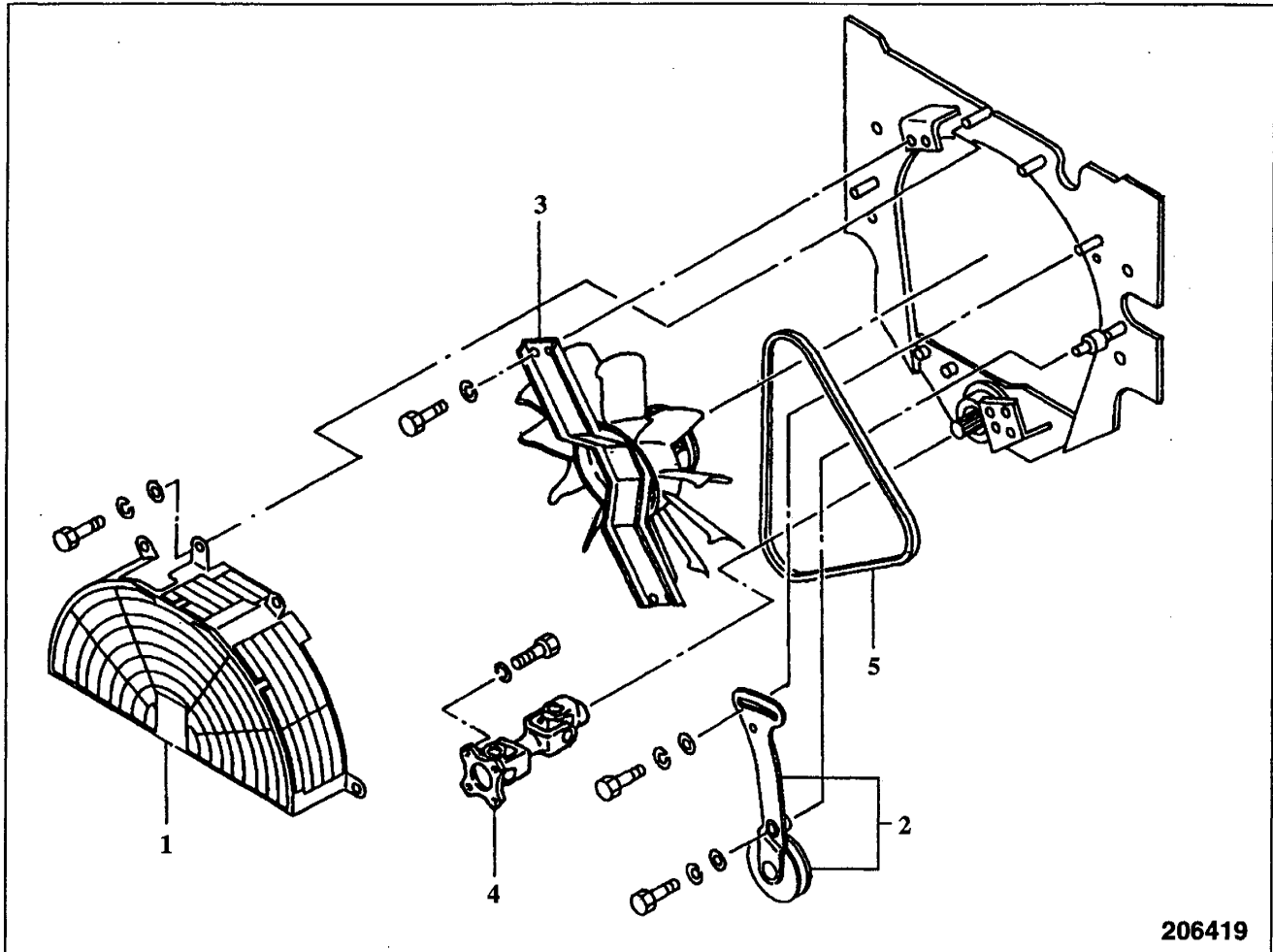

206419

#### Sequence

- |                               |                   |
|-------------------------------|-------------------|
| 1 Fan guard                   | 4 Universal joint |
| 2 Tensioner, Tensioner pulley | 5 Fan belt        |
| 3 Support, Cooling fan        |                   |

#### Start by:

At first stop the engine, then remove the engine hood and gas spring.

#### Suggestions

Make sure the muffler, engine and exhaust pipe are cool enough to touch with your hand.

**BUY NOW**

**Then Instant Download  
the Complete Manual  
Thank you very much!**