



Service Manual

Chassis & Mast

MC/FC

FG10N	F25C-05001-up	FGE15N	F34-00001/19001-up
FG15N	F25C-55001-up	FGE18N	F34-40001/49001-up
FG15ZN	F34-52001-up	FGE20CN	F34-30001/39001-up
FG18N	F25C-75001-up	FGE20N	F17D-20001/38001-up
FG18ZN	F34-72001-up	FGE20ZN	F35-20001/38001-up
FG20CN	F34-22001-up	FGE25N	F17D-70001/88001-up
FG20N	F17D-10001-up	FGE25ZN	F35-70001/88001-up
FG20ZN	F35-10001-up	FGE30N	F13F-10001/20001-up
FG25N	F17D-60001-up	FGE35AN	F13F-80001/90001-up
FG25ZN	F35-60001-up		
FG30N	F13F-40001-up		
FG35AN	F13F-60001-up		
FD10N	F16D-04001-up		
FD15N	F16D-54001/64001-up		
FD18N	F16D-74001/84001-up		
FD20CN	F16D-24001/28001-up		
FD20N	F18C-20001/40001-up		
FD25N	F18C-70001/90001-up		
FD30N	F14E-10001/20001-up		
FD35AN	F14E-80001/90001-up		

For use with S4Q2, S4S and K15/K21/K25 Engine
Service Manuals.

99719-18100

FOREWORD

This service manual is a guide for servicing Mitsubishi forklift trucks. For your convenience the instructions are grouped by systems as a ready reference.

The long productive life of your lift truck(s) depends on regular and proper servicing. Servicing consistent with what you will learn by reading this service manual.

Read the respective sections of this manual carefully and familiarize yourself with all of the components before attempting to start a test, repair or rebuild job.

The descriptions, illustrations and specifications contained in this manual are for trucks with serial numbers in effect at the time of printing.

Mitsubishi Forklift Trucks reserves the right to change specifications or designs without notice and without incurring obligations.

The trucks listed in this manual are powered by K15, K21 or K25 gasoline engines or S4Q2/S4S diesel engines.

For engine servicing, please refer to the applicable engine service manual.

K15, K21 or K25 Gasoline engine

S4Q2, S4S Diesel engine

<Safety Related Signs>



Indicates a specific potential hazard resulting in serious bodily injury or death.



Indicates a potentially hazardous situation which, if not avoided, may result in death or serious injury or damage to the machine.



Indicates a condition that can cause damage to, or shorten service life of, the machine.

SAFETY

WARNING

The proper and safe lubrication and maintenance for these lift trucks, recommended by Mitsubishi Forklift Trucks, are outlined in the OPERATION & MAINTENANCE MANUAL.

Read and understand the OPERATION & MAINTENANCE MANUAL before performing any lubrication or maintenance on these trucks.

Improper performance of lubrication or maintenance procedures is dangerous and could result in injury or death.

The serviceman or mechanic may be unfamiliar with many of the systems on this truck. This makes it important to use caution when performing service work. A knowledge of the system and/or components is important before the removal or disassembly of any component.

Because of the size of some of the truck components, the serviceman or mechanic should check the weights noted in this Manual. Use proper lifting procedures when removing any components.

Following is a list of basic precautions that should always be observed.

- (1) Read and understand all warning plates and decals on the truck before operating, lubricating or repairing the product.
- (2) Always wear protective glasses and protective shoes when working around trucks. In particular, wear protective glasses when pounding on any part of the truck or its attachments with a hammer or sledge. Use welders gloves, hood/goggles, apron and other protective clothing appropriate to the welding job being performed. Do not wear loose fitting or torn clothing. Remove all rings from fingers when working on machinery.
- (3) Do not work on any truck that is supported only by lift jacks or a hoist. Always use blocks or jack stands to support the truck before performing any disassembly.
- (4) Lower the forks or other implements to the ground before performing any work on the truck. If this cannot be done, make sure the forks or other implements are blocked correctly to prevent them from dropping unexpectedly.

WARNING

Do not operate these trucks unless you have read and understood the instructions in the OPERATION & MAINTENANCE MANUAL. Improper truck operation is dangerous and could result in injury or death.

- (5) Use steps and grab handles (if applicable) when mounting or dismounting a truck. Clean any mud or debris from steps, walkways or work platforms before using. Always face truck when using steps, ladders and walkways. When it is not possible to use the designed access system, provide ladders, scaffolds, or work platforms to perform safe repair operations.
- (6) To avoid back injury, use a hoist when lifting components which weigh 23 kg or more. Make sure all chains, hooks, slings, etc., are in good condition and are of the correct capacity. Be sure hooks are positioned correctly. Lifting eyes are not to be side loaded during a lifting operation.
- (7) To avoid burns, be alert for hot parts on trucks which have just been stopped and hot fluids in lines, tubes and compartments.
- (8) Be careful when removing cover plates. Gradually back off the last two bolts or nuts located at opposite ends of the cover or device and pry cover loose to relieve any spring or other pressure, before removing the last two bolts or nuts completely.
- (9) Be careful when removing filler caps, breathers and plugs on the truck. Hold a rag over the cap or plug to prevent being sprayed or splashed by liquids under pressure. The danger is even greater if the truck has just been stopped because fluids can be hot.
- (10) Always use tools that are in good condition and be sure you understand how to use them before performing any service work.
- (11) Reinstall all fasteners with same part number. Do not use a lesser quality fastener if replacements are necessary.
- (12) If possible, make all repairs with the truck parked on a level, hard surface. Block truck so it does not roll while working on or under truck.

- (13) Disconnect battery and discharge any capacitors (electric trucks) before starting to work on truck. Hang "Do not Operate" tag in the Operator's Compartment.
- (14) Repairs, which require welding, should be performed only with the benefit of the appropriate reference information and by personnel adequately trained and knowledgeable in welding procedures. Determine type of metal being welded and select correct welding procedure and electrodes, rods or wire to provide a weld metal strength equivalent at least to that of parent metal.
- (15) Do not damage wiring during removal operations. Reinstall the wiring so it is not damaged nor will it be damaged in operation by contacting sharp corners, or by rubbing against some object or hot surface. Place wiring away from oil pipe.
- (16) Be sure all protective devices including guards and shields are properly installed and functioning correctly before starting a repair. If a guard or shield must be removed to perform the repair work, use extra caution.
- (17) Always support the mast and carriage to keep carriage or attachments raised when maintenance or repair work is performed, which requires the mast in the raised position.
- (18) Loose or damaged fuel, lubricant and hydraulic lines, tubes and hoses could cause fires. Do not bend or strike high pressure lines or install ones which have been bent or damaged. Inspect lines, tubes and hoses carefully. Do not check for leaks with your hands. Pin hole (very small) leaks could result in a high velocity oil stream that will be invisible close to the hose. This oil could penetrate the skin and cause personal injury. Use cardboard or paper to locate pin hole leaks.
- (19) Tighten connections to the correct torque. Make sure that all heat shields, clamps and guards are installed correctly to avoid excessive heat, vibration or rubbing against other parts during operation. Shields that protect against oil spray onto hot exhaust components in event of a line, tube or seal failure, must be installed correctly.
- (20) Relieve all pressure in air, oil or water systems before any lines, fittings or related items are disconnected or removed. Always make sure all raised components are blocked correctly and be alert for possible pressure when disconnecting any device from a system that utilizes pressure.
- (21) Do not operate a truck if any rotating part is damaged or contacts any other part during operation. Any high speed rotating component that has been damaged or altered should be checked for balance before reusing.

HOW TO USE THIS MANUAL

Lift truck models covered in this manual

- MC Truck (Mechanical Control System)
Mechanically controlled hydraulic system (conventional lever system)
- FC Truck (Finger-tip Control System)
Electronically controlled hydraulic system

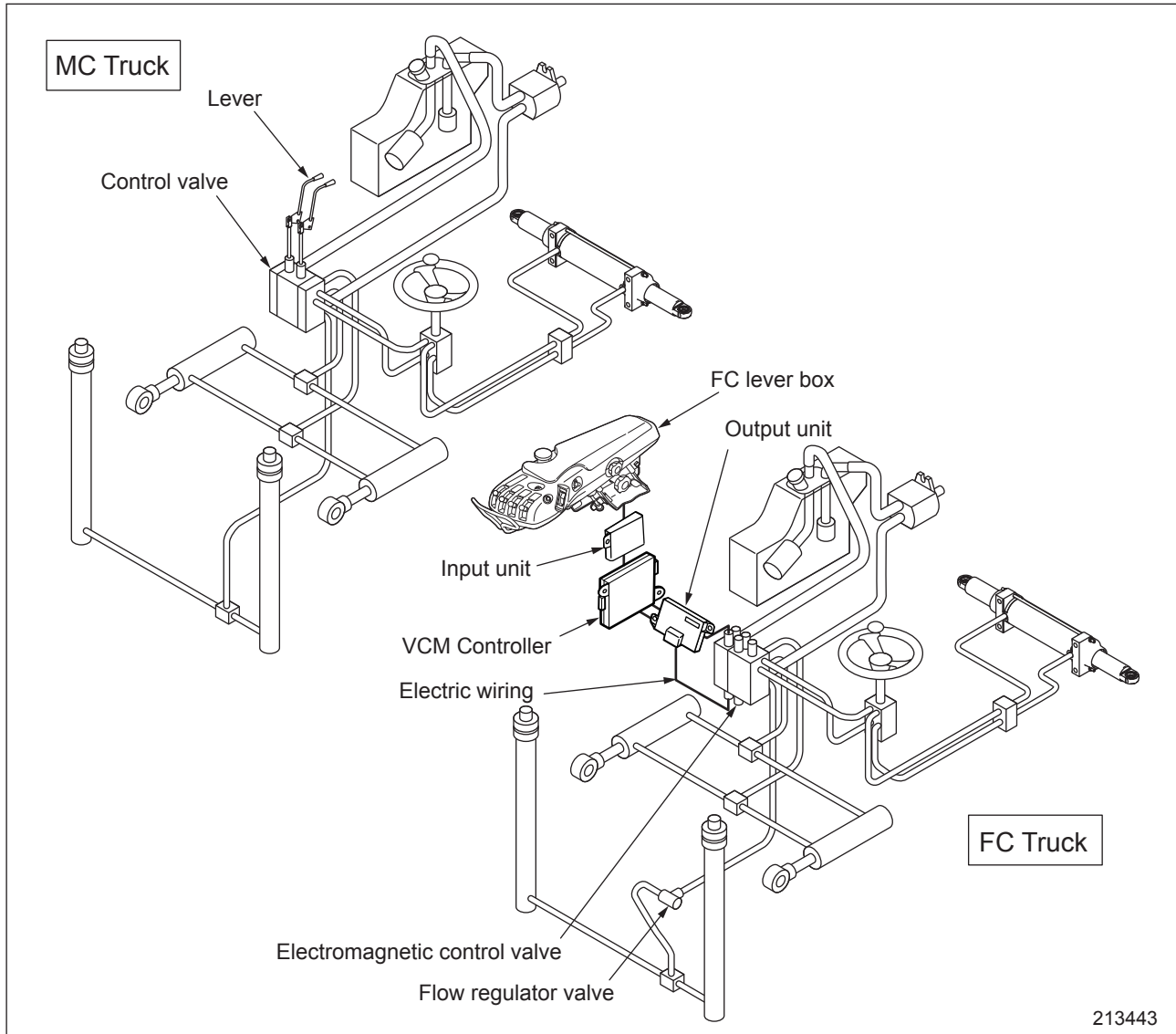

213443

- Gasoline-Engine Trucks (FGE, FG)..... Trucks Equipped with K21 or K25 Gasoline Engine
- Diesel-Engine Trucks (FD)..... Trucks Equipped with K21 or K25 Diesel Engine
- Powershift Trucks..... Trucks Equipped with Powershift Transmission
- Manual Transmission Trucks..... Trucks Equipped with Manual Transmission
(2 Types of Clutch; Dry and Wet)

HOW TO USE THIS MANUAL (continued)

(Removal, Installation, Assembly and Disassembly)

Disassembly diagram (example)

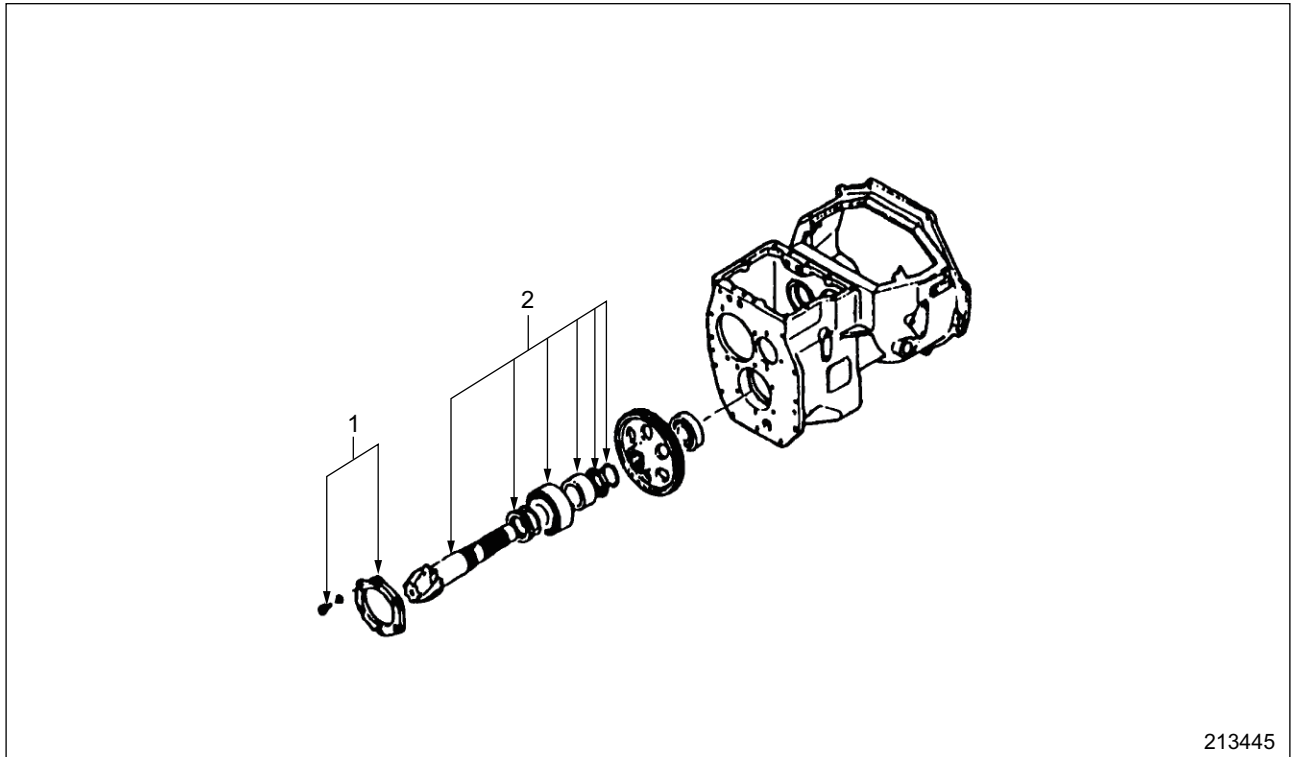

213445

Sequence

- 1 Cover, Bolt, Washer (part name)
- 2 Snap ring (part name)

Suggestions for Disassembly

Output shaft, Removing

Remove output shaft using a special tool.

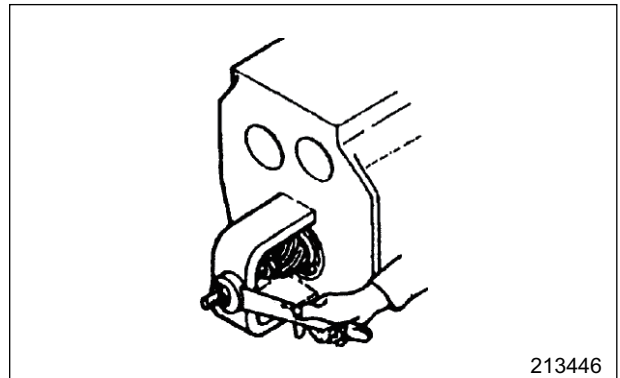

213446

Service Data

Gear Backlash	A	0.11 to 0.28 mm
	B	0.5 mm

A: Standard value

B: Repair or Service Limit

Symbols and abbreviations

OP	Option
R1/4	Taper pipe thread (external) 1/4 inch (formerly PT1/4)
RC1/8	Taper pipe thread (external) 1/4 inch (formerly PT1/8)
G1/4A	Straight pipe thread (external) 1/4 inch (formerly PF1/4-A)
Rp1/8	Straight pipe thread (internal) 1/8 inch (formerly PS1/8)

Units

- (1) SI Units are used in this manual.
- (2) The following table shows the conversion of SI unit and customary unit.

Item	SI unit	Customary unit
Force	1 N	0.102 kgf
	1 lbf	0.4536 kgf
Pressure	1 kPa	0.0102 kgf/cm ²
	1 psi	0.0703 kgf/cm ²
Torque	1 N·m	0.102 kgf·m
	1 lbf·ft	0.1383 kgf·m

CHAPTER INDEX

CHAPTER INDEX	Items
GENERAL INFORMATION	Truck Models Covered, Serial Number Locations, Dimensions, Technical Data
COOLING SYSTEM	Fan Belt Removal and Installation, Fan Belt Tension
ELECTRICAL SYSTEM	Console Box, Chassis Electrical Devices, Battery Maintenance, Electrical Schematic
CONTROLLERS	Main Functions of Controller, Input/Output Monitor, Error Codes and Troubleshooting
POWER TRAIN	Removal and Installation of Power Line
CLUTCHES	Dry-Type Clutch, Wet-Type Clutch
MANUAL TRANSMISSION	Structure, Removal and Installation of Transmission
POWERSHIFT TRANSMISSION	Torque Converter, Single Speed Powershift Transmission Control Valve, Automatic Two-Speed Transmission
FRONT AXLE AND REDUCTION DIFFERENTIAL	Front Tire, Front Axle, Reduction, Differential
REAR AXLE	Rear Axle, Rear Tire
BRAKE SYSTEM	Master Cylinder, Wheel Brake, Brake Booster
STEERING SYSTEM	Steering Gear, Power Cylinder, Flow Divider
HYDRAULIC SYSTEM	Tank, Pump, Control Valve, Lift and Tilt Cylinders, Flow Regulator Valve, Down Safety Valve
MAST AND FORKS	Simplex and Duplex Masts, Triplex Mast
SERVICE DATA	Maintenance Standard, Maintenance Schedule, Periodic Replacement Parts, Lubrication Instruction, Special Tool Needed

1

2

3

4

5

6

7

8

9

10

11

12

13

14

15

Chapter 1 GENERAL INFORMATION

1. Model View.....	1-1
2. Truck Models Covered.....	1-2
3. Serial Number Locations.....	1-3
4. Dimensions.....	1-4
5. Technical Data.....	1-5
6. Performance	1-7

1. Model View

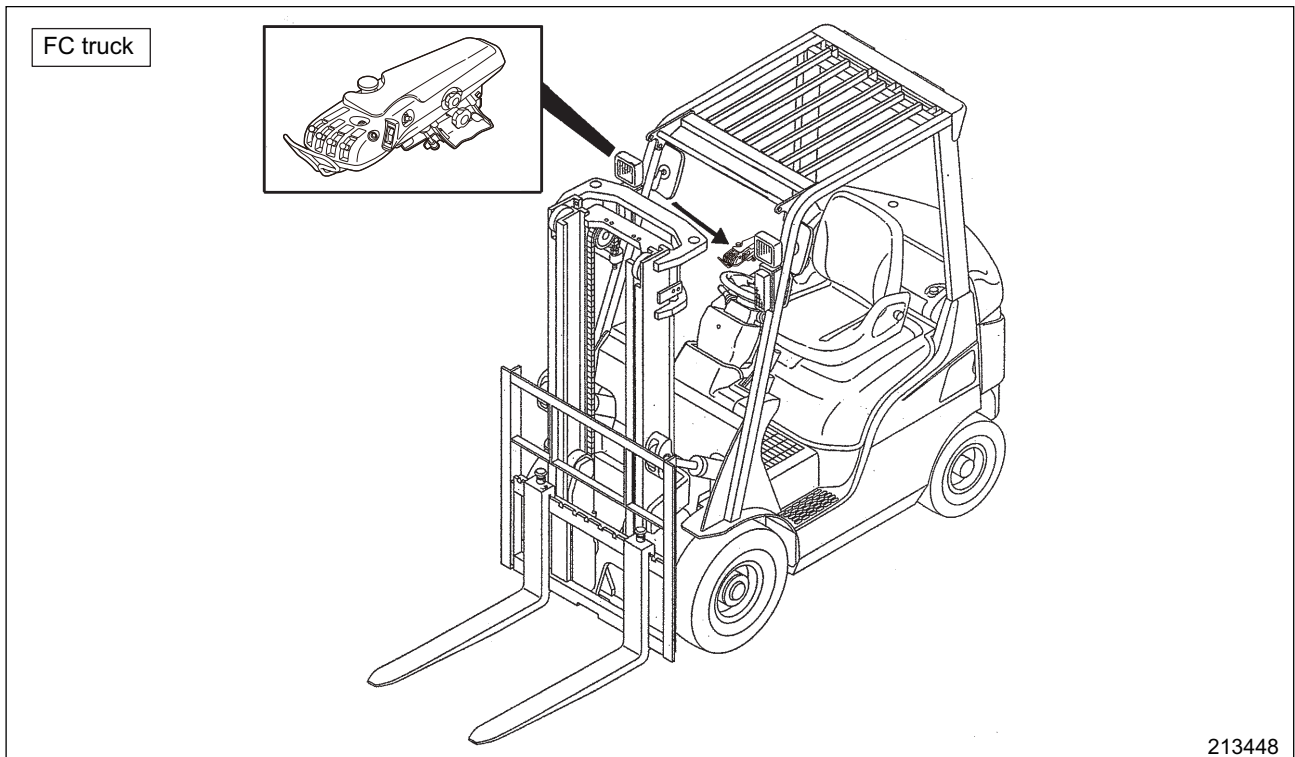
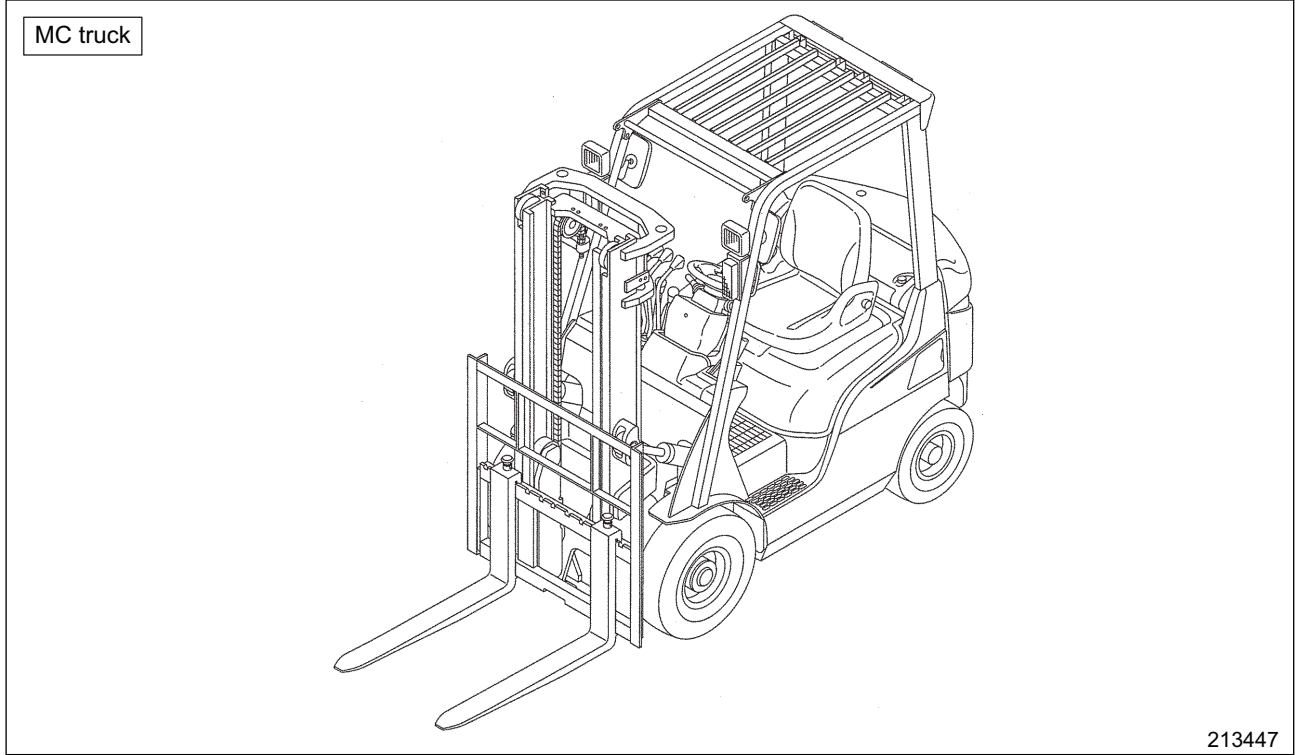

2. Truck Models Covered

This Service Manual provides servicing and maintenance information for the following trucks:

Engine mounted	Gasoline-engine truck	Dual fuel gasoline/ LPG-engine truck	Diesel-engine truck
Non-electric controlled	MC / FC	MC / FC	MC / FC
Electric controlled	MC / FC	MC / FC	-

(FC type is used in torque converter model only.)

Truck type	Electric controlled gasoline engine, Electric controlled dual fuel gasoline/ LPG engine models			Non-electric controlled diesel engine models		
	Truck model	Serial number	Engine mounted	Truck model	Serial number	Engine mounted
1 ton class	FG10N	F25C-05001 to	K15	FD10N	F16D-04001 to	S4Q2
	FG15N	F25C-55001 to	K15	FD15N	F16D-54001 to	S4Q2
	FG15ZN	F34-52001 to	K21	FD15N(F)	F16D-64001 to	S4Q2
	FGE15N	F34-00001 to	K21E	FD18N	F16D-74001 to	S4Q2
	FGE15N(F)	F34-19001 to	K21E	FD18N(F)	F16D-84001 to	S4Q2
	FG18N	F25C-75001 to	K15	FD20CN	F16D-24001 to	S4Q2
	FG18ZN	F34-72001 to	K21	FD20CN(F)	F16D-28001 to	S4Q2
	FGE18N	F34-40001 to	K21E	-	-	-
	FGE18N(F)	F34-49001 to	K21E	-	-	-
	FG20CN	F34-22001 to	K25	-	-	-
	FGE20CN	F34-30001 to	K25E	-	-	-
FGE20CN(F)	F34-39001 to	K25E	-	-	-	
2 ton class	FG20N	F17D-10001 to	K21	FD20N	F18C-20001 to	S4S
	FG20ZN	F35-10001 to	K25	FD20N(F)	F18C-40001 to	S4S
	FGE20N	F17D-20001 to	K21E	FD25N	F18C-70001 to	S4S
	FGE20N(F)	F17D-38001 to	K21E	FD25N(F)	F18C-90001 to	S4S
	FGE20ZN	F35-20001 to	K25E	-	-	-
	FGE20ZN(F)	F35-38001 to	K25E	-	-	-
	FG25N	F17D-60001 to	K21	-	-	-
	FG25ZN	F35-60001 to	K25	-	-	-
	FGE25N	F17D-70001 to	K21E	-	-	-
	FGE25N(F)	F17D-88001 to	K21E	-	-	-
	FGE25ZN	F35-70001 to	K25E	-	-	-
FGE25ZN(F)	F35-88001 to	K25E	-	-	-	
3 ton class	FG30N	F13F-40001 to	K25	FD30N	F14E-10001 to	S4S
	FGE30N	F13F-10001 to	K25E	FD30N(F)	F14E-20001 to	S4S
	FGE30N(F)	F13F-20001 to	K25E	FD35AN	F14E-80001 to	S4S
	FG35AN	F13F-60001 to	K25	FD35AN(F)	F14E-90001 to	S4S
	FGE35AN	F13F-80001 to	K25E	-	-	-
	FGE35AN(F)	F13F-90001 to	K25E	-	-	-

Note: Characters at the end of truck model should be read as follows:

(F) : FC Truck

None : MC Truck

Z : High-power engine model

C : Short wheel base model

3. Serial Number Locations

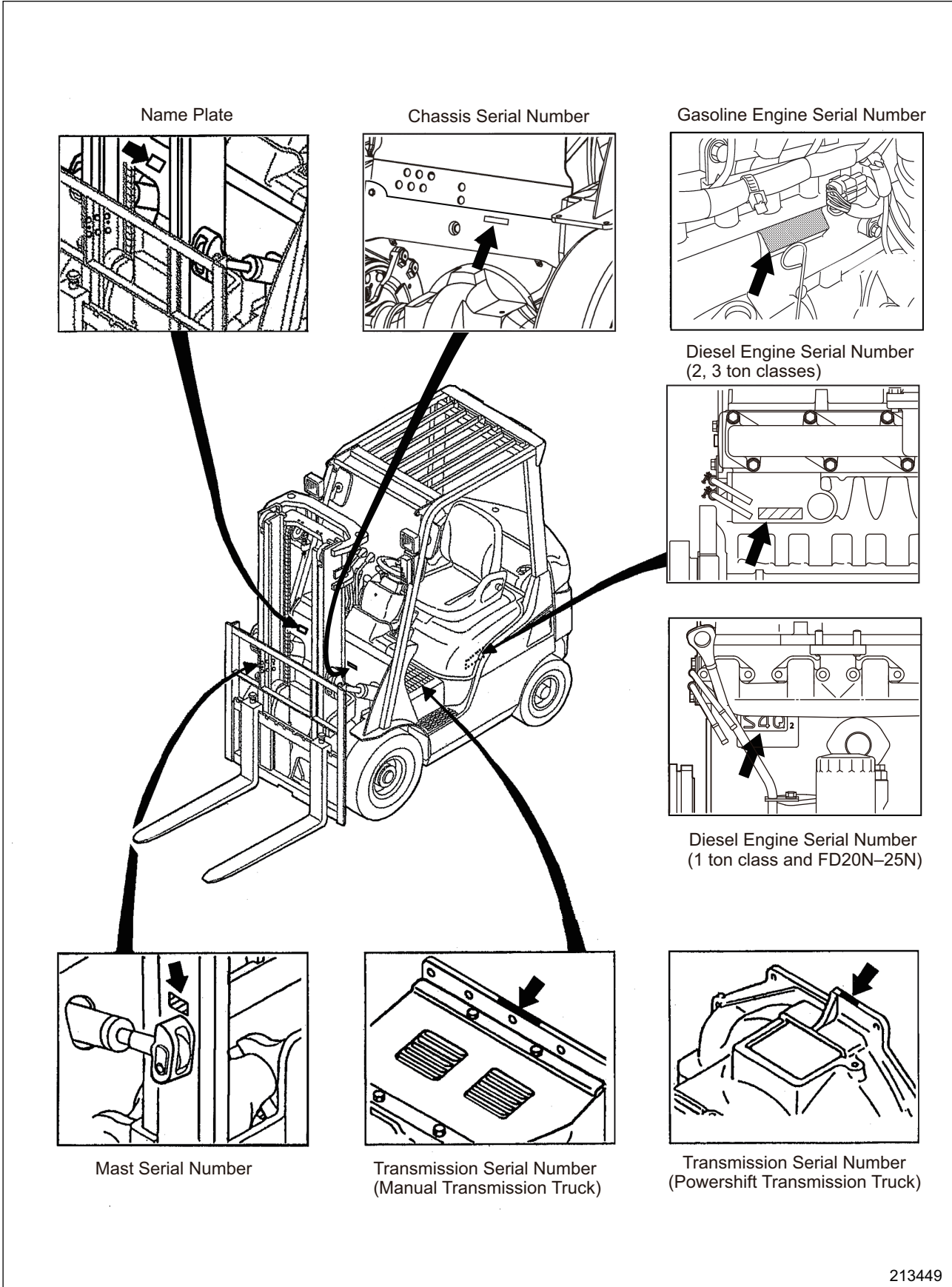

213449

4. Dimensions

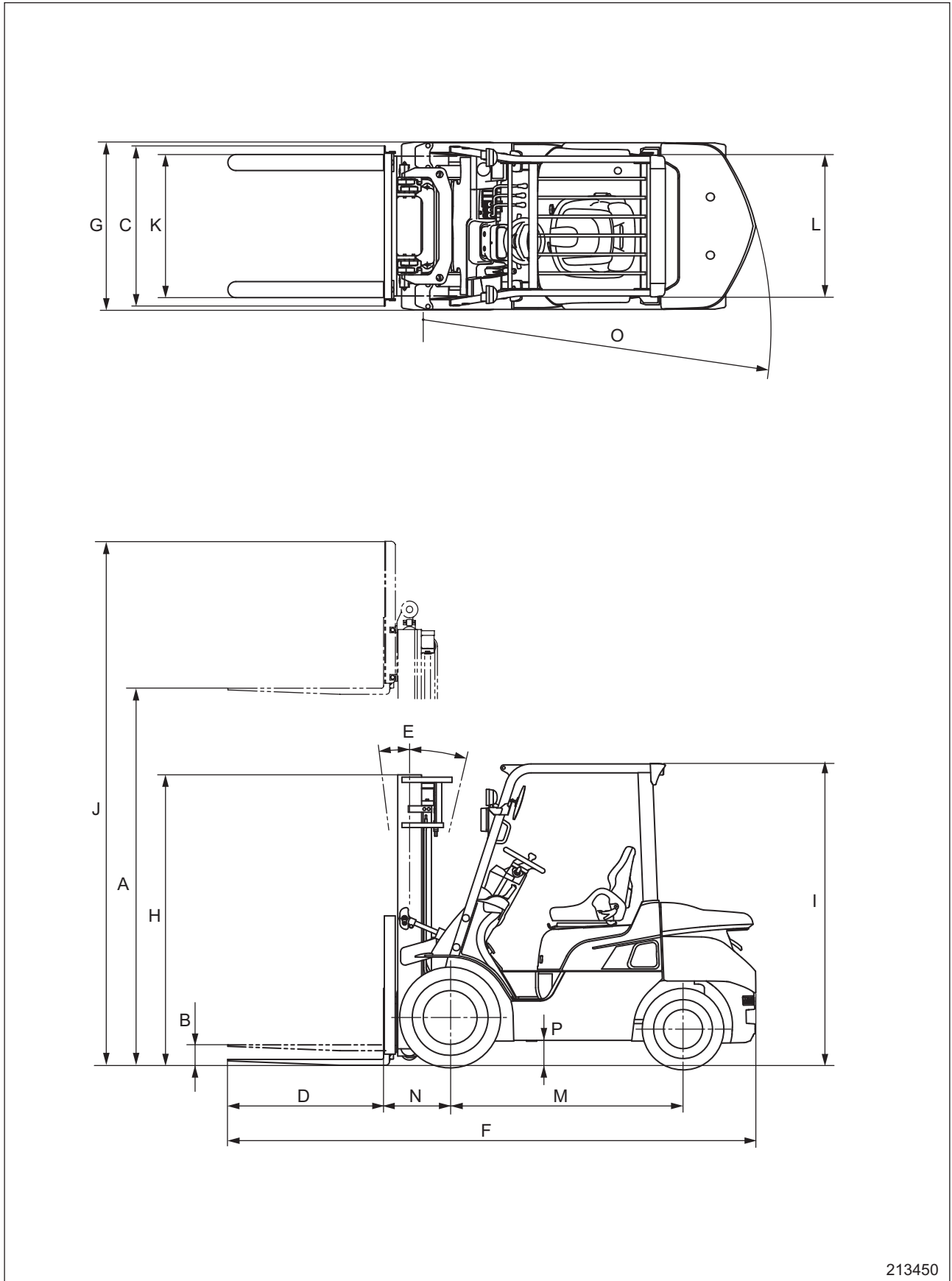

213450

5. Technical Data

Unit: mm

Truck model		class	1 ton class			
		Gasoline-engine truck	FG10N	FG15N FGE15N FG15ZN	FG18N FGE18N FG18ZN	FG20CN FGE20CN
			Diesel-engine truck	FD10N	FD15N	FD18N
A	Maximum lift		3000	3000	3000	3000
B	Free lift height		115	115	115	120
C	Fork spread		200 to 920	200 to 920	200 to 920	220 to 920
D	Fork length		770	920	920	920
E	Tilt angle (forward – backward)		6-12	6-12	6-12	6-12
F	Overall length		2980	3180	3220	3280
G	Overall width (outside-to-outside of tires)	Single	1065	1065	1065	1065
		Double	1330	1330	1330	-
H	Overall height (with mast lowered)		1990	1990	1990	1990
I	Height of the overhead guard		2065	2065	2065	2065
J	Overall height (with mast extended)		4055	4055	4055	4055
K	Tread (front wheel)	Single	890	890	890	890
		Double	1025	1025	1025	-
L	Tread (rear wheel)		900	900	900	900
M	Wheel base		1400	1400	1400	1400
N	Front overhang		400	400	400	415
O	Minimum turning radius		1910	1950	1980	2020
P	Under clearance (at center of frame)		150	150	150	150

GENERAL INFORMATION

Unit: mm

Truck model		class	2 ton class		3 ton class	
		Gasoline-engine truck	FG20N FGE20N FG20ZN FGE20ZN	FG25N FGE25N FG25ZN FGE25ZN	FG30N FGE30N	FG35AN FGE35AN
			Diesel-engine truck	FD20N	FD25N	FD30N
A	Maximum lift		3000	3000	3000	3000
B	Free lift height		140	145	145	145
C	Fork spread		220 to 1000	220 to 1000	250 to 1000	250 to 1000
D	Fork length		920	920	1070	1070
E	Tilt angle (forward – backward)		6-12	6-12	6-12	6-12
F	Overall length		3410	3625	3795	3860
G	Overall width (outside-to-outside of tires)	Single	1150	1150	1275	1290
		Double	1480	1480	1490	1490
H	Overall height (with mast lowered)		1990	1990	2015	2130
I	Height of the overhead guard		2074	2074	2093	2103
J	Overall height (with mast extended)		4055	4055	4055	4055
K	Tread (front wheel)	Single	960	960	1060	1060
		Double	1140	1140	1140	1140
L	Tread (rear wheel)		980	980	980	980
M	Wheel base		1600	1600	1700	1700
N	Front overhang		455	460	495	495
O	Minimum turning radius		2200	2230	2380	2440
P	Under clearance (at center of frame)		160	160	190	200

6. Performance

Truck model	class		1 ton class			
	Gasoline-engine truck		FG10N	FG15N FGE15N FG15ZN	FG18N FGE18N FG18ZN	FG20CN FGE20CN
	Diesel-engine truck		FD10N	FD15N	FD18N	FD20CN
Capacity		kg	1000	1500	1750	2000
Load center		mm	500	500	500	500
Lift speed	Loaded	mm/s	490 (FG10N)	490 (FG15N) 630 (FGE15N) 570 (FG15ZN)	490 (FG18N) 630 (FGE18N) 570 (FG18ZN)	570 (FG20CN) 630 (FGE20CN)
			630 (FD10N)	630 (FD15N)	630 (FD18N)	630 (FD20CN)
	Unloaded	mm/s	560 (FG10N)	560 (FG15N) 650 (FGE15N) 650 (FG15ZN)	560 (FG18N) 650 (FGE18N) 650 (FG18ZN)	650 (FG20CN) 650 (FGE20CN)
			690 (FD10N)	690 (FD15N)	690 (FD18N)	690 (FD20CN)
Travel speed (Powershift Truck)	Loaded	km/h	19.0	19.0	19.0	19.0
	Unloaded	km/h	19.5	19.5	19.5	19.5

GENERAL INFORMATION

Truck model	class		2 ton class		3 ton class	
	Gasoline-engine truck		FG20N FGE20N FG20ZN FGE20ZN	FG25N FGE25N FG25ZN FGE25ZN	FG30N FGE30N	FG35AN FGE35AN
	Diesel-engine truck		FD20N	FD25N	FD30N	FD35AN
Capacity		kg	2000	2500	3000	3500
Load center		mm	500	500	500	500
Lift speed	Loaded	mm/s	520 (FG20N) 580 (FGE20N) 580 (FG20ZN) 640 (FGE20ZN)	520 (FG25N) 580 (FGE25N) 580 (FG25ZN) 640 (FGE25ZN)	460 (FG30N) 510 (FGE30N)	390 (FG35AN) 430 (FGE35AN)
			630 (FD20N)	630 (FD25N)	500 (FD30N)	420 (FD35AN)
	Unloaded	mm/s	600 (FG20N) 590 (FGE20N) 660 (FG20ZN) 660 (FGE20ZN)	600 (FG25N) 590 (FGE25N) 660 (FG25ZN) 660 (FGE25ZN)	530 (FG30N) 530 (FGE30N)	450 (FG35AN) 440 (FGE35AN)
			660 (FD20N)	660 (FD25N)	530 (FD30N)	450 (FD35AN)
Travel speed (Powershift Truck)	Loaded	km/h	19.0	19.0	19.0	19.0
	Unloaded	km/h	19.5	19.5	19.5	19.5

Chapter 2 COOLING SYSTEM

1. Specifications	2-1
2. Structure	2-2
3. Removal and Installation	2-3
3.1 Fan Belt Removal	2-3
3.2 Suggestions for Removal	2-3
3.3 Installation	2-4
4. Inspection and Adjustment	2-5
4.1 Fan Belt Inspection.....	2-5
4.2 Fan Belt Tension	2-5
4.3 Connecting Hoses	2-5
4.4 Unit Layout	2-6
4.5 Coolant	2-6
4.6 Radiator Cap	2-6

BUY NOW

**Then Instant Download
the Complete Manual
Thank you very much!**