

# TB80FR

Compact Excavator

**WORKSHOP MANUAL**

**TAKEUCHI**

## **FOREWORD**

This manual is intended for persons who engage in maintenance operations, and explains procedures for disassembly and reassembly of the machine, check and maintenance procedures, maintenance reference values, troubleshooting and outline specifications, etc. Please use this manual as a reference in service activities to improve maintenance techniques.

Further, please be advised that items contained in this manual are subject to change without notice due to design modifications, etc.

### **MACHINE FRONT AND REAR, LEFT AND RIGHT**

The end where the dozer blade is mounted is the front and the end with the travel motors is the rear. Also the right and left sides of the operator when he is seated in the driver's seat are the right and left sides of the machine.

### **MACHINE SERIAL NUMBER**

The machine serial number is stamped on the identification plate. When sending reports and inquiries, and when ordering parts, etc., be sure to include this number.

### **MANUAL CONTROL**

Information on those to whom this manual is distributed is recorded in the ledger in the section in charge at this company, so please decide on a person to be in charge of it and control it. When there are updates or additions, etc., we will notify the person in charge.

**FOOT OF THE PAGE**

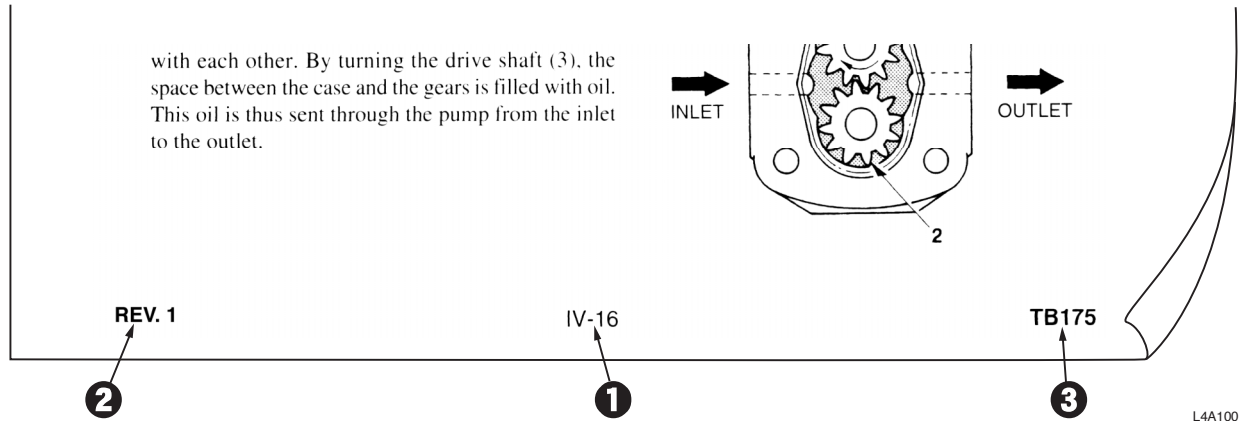

**1. Page number**

The following page numbers are assigned to each respective page. And if there are additional pages, an addition code is supplied. Please file the sheets in the order of the page numbers.

Page No.

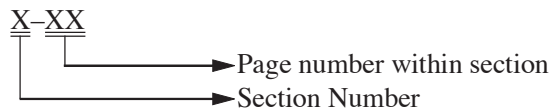

Page Addition



- Example: II-8  
 II-9  
 II-9-1 ..... A page is added between page 9 and page 10.  
 II-10

If a page has been revised, it is to be used in place of the page used before revision and it is not necessary to keep the old page.

**2. Revision number**

Indicates the latest revision of this manual. This number is printed on the page that reflects this revision.

**3. Model (s)**

**SYMBOLS**

means "Please refer to the section quoted."

Indicates the tightening torque at the specific section that requires special attention in designing.

Indicates the mass of a part or device.

- I . GENERAL**
- II . SPECIFICATIONS**
- III. MACHINE CONFIGURATION**
- IV. HYDRAULIC UNITS**
- V . TROUBLESHOOTING**
- VI. ENGINE**

# **I . GENERAL**

**CONTENTS**

Safety Precautions ..... 3  
Cautions during Disassembly and Assembly ..... 9  
Cautions during Removal and Installation of the Hydraulic Units ..... 10  
Cautions during Removal and Installation of Piping ..... 11  
Handling of Seals ..... 12  
Tightening Torques ..... 13

## SAFETY PRECAUTIONS



### SAFETY ALERT SYMBOL

This symbol means Attention! Be Alert! Your Safety Is Involved.

The message that follows the symbol contains important information about safety.

Read and understand the message to avoid personal injury or death.

### ■ SIGNAL WORDS

Safety messages appearing in this manual and on machine decals are identified by the words “DANGER”, “WARNING” and “CAUTION”. These signal words mean the following:

**⚠ DANGER**

The word “DANGER” indicates an imminently hazardous situation which, if not avoided, can result in serious injury or death.

**⚠ WARNING**

The word “WARNING” indicates a potentially hazardous situation which, if not avoided, could result in serious injury or death.

**⚠ CAUTION**

The word “CAUTION” indicates a potentially hazardous situation which, if not avoided, may result in minor or moderate injury.

**IMPORTANT:** The word “IMPORTANT” is used to alert against operators and maintenance personnel about situations which can result in possible damage to the machine and its components.

This manual is intended for trained and qualified personnel only. Warnings or cautions described in this manual do not necessarily cover all safety measures. For maintenance work, each person must take adequate safety precautions against possible hazards present in the respective working environment.

### Observe all safety rules

- Operation, inspection and maintenance of this machine must be performed only by a trained and qualified person.
- All rules, regulations, precautions and safety procedures must be understood and followed when performing operation, inspection and maintenance of this machine.
- Do not perform any operation, inspection and maintenance of this machine when under the adverse influence of alcohol, drugs, medication, fatigue, or insufficient sleep.



E3A040

### Wear appropriate clothing and personal protective equipment

- Do not wear loose clothing or any accessory that can catch on controls or in moving parts.
- Do not wear oily or fuel stained clothing that can catch fire.

- Wear a hard hat, safety shoes, safety glasses, filter mask, heavy gloves, ear protection and other protective equipment as required by job conditions. Wear required appropriate equipment such as safety glasses and filter mask when using grinders, hammers or compressed air, as metal fragments or other objects can fly and cause serious personal injury.
- Use hearing protection when operating the machine. Loud prolonged noise can cause hearing impairments, even the total loss of hearing.

## GENERAL

### Provide a fire extinguisher and first aid kit

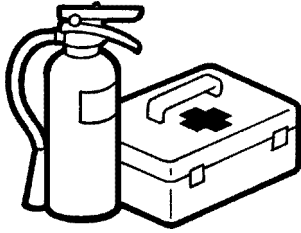

E3A080

- Know where a fire extinguisher and first aid kit are located and understand how to use them.
- Know how to contact emergency assistance and first aid help.

### Attach a “DO NOT OPERATE” tag

Severe injury could result if an unauthorized person should start the engine or touch controls during inspection or maintenance.

- Stop the engine and remove the key before performing maintenance.
- Attach a “DO NOT OPERATE” tag to the starter switch or control lever.

### Use the correct tools



E3A530

Do not use damaged or weakened tools or tools designed for other purposes. Use tools suited for the operation at hand.

### Replace important safety parts periodically

- Replace fuel hoses periodically. Fuel hoses become weaker over time, even if they appear to be in good shape.
- Replace important safety parts whenever an irregularity is found, even if it is before the normal time for replacement.

### Anti-explosive lighting



E3A550

Use anti-explosive electrical fixtures and lights when inspecting fuel, oil, coolant, battery fluid, etc. If lighting that is not anti-explosive should break, the substance could ignite, resulting in serious injury or death.

### Do not allow unauthorized personnel in the work area

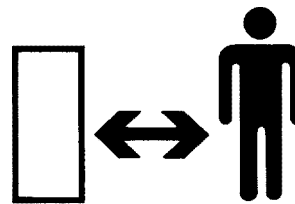

E3A140

Do not allow unauthorized personnel in the work area. Chips or other debris can fly off machine parts when grinding, welding or using a hammer.

### Prepare the work area

- Select a firm, level work area. Make sure there is adequate light and, if indoors, ventilation.
- Clear obstacles and dangerous objects. Eliminate slippery areas.

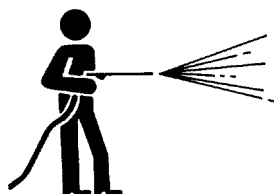

**Always clean the machine**

E3A580

- Clean the machine before performing maintenance.
- Cover electrical parts when washing the machine. Water on electrical parts could cause short-circuits or malfunctions. Do not use water or steam to wash the battery, sensors, connectors or the operator's seat area.

**Stop the engine before performing maintenance**

- Avoid lubrication or mechanical adjustments with the machine in motion or with the engine running while stationary.
- If maintenance must be performed with the engine running, always work as a 2-person team with one person sitting in the operator's seat while the other works on the machine.
  - When performing maintenance, be sure to keep your body and clothing away from moving parts.

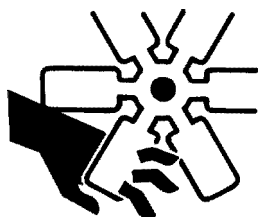
**Stay clear of moving parts**

E3A630

- Stay clear of all rotating and moving parts. Wrapping or entanglement may result in serious injury or death.
- Keep hands, clothing and tools away from the rotating fan and running fan belts.

**Securely block the machine or any component that may fall**

E3A570

- Before performing maintenance or repairs under the machine, set all working equipment against the ground or in the lowermost position.
- Securely block the tracks.
- If you must work beneath the raised machine or equipment, always use wood blocks, jack-stands or other rigid and stable supports. Never get under the machine or working equipment if they are not sufficiently supported. This procedure is especially important when working on hydraulic cylinders.

**Securely block the working equipment**

To prevent unexpected movement, securely block the working equipment when repairing or replacing the cutting edges or bucket teeth.

**Secure the engine hood or cover when opened**

Be sure to secure the engine hood or cover when opening it. Do not open the engine hood or cover on slopes or in strong wind.

**Cautions on tilting up the platform**

- Raising or lowering the platform while the engine is running may cause the machine to move, and cause serious injury or death. Stop the engine before raising or lowering the platform.
- When the floor is tilted up, support it firmly with the stopper to prevent it from falling.

## GENERAL

### Place heavy objects in a stable position



E3A560

When removing or installing the hoe attachment, place it in a stable position so that it does not tip over.

### Use caution when fueling



E3A100

- Do not smoke or permit open flames while fueling or near fueling operations.
- Never remove the fuel cap or refuel with the engine running or hot. Never allow fuel to spill on hot machine components.
- Maintain control of the fuel filler nozzle when filling the tank.
- Do not fill the fuel tank to capacity. Allow room for expansion.
- Clean up spilled fuel immediately.
- Tighten the fuel tank cap securely. Should the fuel cap be lost, replace it only with the original manufacturer's approved cap. Use of a non-approved cap without proper venting may result in pressurization of the tank.
- Never use fuel for cleaning purposes.
- Use the correct fuel grade for the operating season.

### Handling of hoses

Fuel, oil or hydraulic fluid leaks can cause a fire.

- Do not twist, bend or hit the hoses.
- Never use twisted, bent or cracked hoses, tubes and pipes. They may burst.
- Retighten loose connections.

### Be careful with hot and pressurized components



E3A110

Stop the engine and allow the machine to cool down before performing inspection and maintenance.

- The engine, muffler, radiator, hydraulic lines, sliding parts and many other parts of the machine are hot directly after the engine is stopped. Touching these parts will cause burns.
- The engine coolant, oil and hydraulic fluid are also hot and under high pressure. Be careful when loosening caps and plugs. Working on the machine under these conditions could result in burns or injuries due to the hot oil spurting out.

### Be careful with hot cooling systems

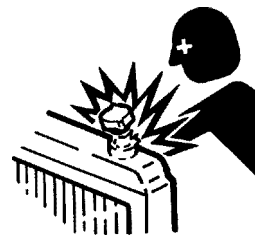

E3A540

Do not remove the radiator cap or drain plugs when the coolant is hot. Stop the engine, let the engine and radiator cool and loosen the radiator cap or drain plugs slowly.

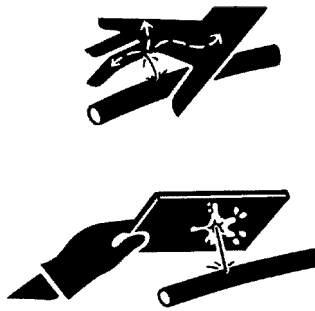
**Be careful with fluids under pressure**

E3A600

Pressure can be maintained in the hydraulic circuit long after the engine has been shut down.

- Release all pressure before working on the hydraulic system.
- Hydraulic fluid under pressure can penetrate the skin or eyes and cause injury, blindness or death. Fluid escaping from a small hole can be almost invisible. Wear a safety goggles and heavy gloves and use a piece of cardboard or wood to search for suspected leaks.

If fluid is injected into the skin, it must be removed within a few hours by a doctor familiar with this type of injury.

**Release all pressure before working on the hydraulic system**

Oil may spurt out if caps or filters are removed or pipes disconnected before releasing the pressure in the hydraulic system.

- Gradually loosen the vent plug to relieve tank pressure.
- Move all the control levers and pedals several times in all directions to release the pressure from the working equipment circuitry. (For link type controls)
- When removing plugs or screws or disconnecting hoses, stand to the side and loosen slowly to gradually release the internal pressure before removing.

**Be careful with grease under pressure**

E3A620

The track adjuster contains highly pressurized grease. If the tension is adjusted without following the prescribed procedure, the grease discharge valve may fly off, resulting in injury.

- Loosen the grease discharge valve slowly. Do not unfasten it more than one full turn.
- Do not put your face, arms, legs or body in front of the grease discharge valve.

**Disconnect the battery**

E3A590

Disconnect the battery before working on the electrical system or doing any welding. Remove the negative (–) battery cable first. When reconnecting the battery, connect the negative (–) battery cable last.

## GENERAL

### Avoid battery hazards

- Batteries contain sulfuric acid which will damage eyes or skin on contact.
  - If acid contacts eyes, flush immediately with clean water and get prompt medical attention.
  - If acid is accidentally swallowed, drink large quantities of water or milk and call a physician immediately.
  - If acid contacts skin or clothing, wash off immediately with clean water.
- Wear safety glasses and gloves when working with batteries.
- Batteries generate flammable and explosive gases. Keep arcs, sparks, flames and lighted tobacco away.
- Use a flashlight to check battery electrolyte level.
- Stop the engine and shut off electrical equipment while inspecting or handling the battery.
- Do not short circuit the battery posts with metal items.
- Always unfasten the negative (–) battery cable first when disconnecting the battery cable. Always connect the negative (–) battery cable last when fastening the battery cable.
- Loose battery terminals may result in sparks. Be sure to fasten terminals tightly.
- Make sure the vent caps are tightened securely.
- Do not charge a battery or jump-start the engine if the battery is frozen. Warm to 15°C (60°F) or the battery may explode.

### Have a Takeuchi service agent repair welding cracks or other damage

Ask a Takeuchi service agent to repair any welding problems which are detected. If not feasible, make sure the welding is done by a qualified person in a properly equipped workplace.

### Safety signs

- Keep all safety signs clean and legible.
- Replace all missing, illegible or damaged safety and warning signs.

### Checks after maintenance

- Gradually raise the engine speed from a low idle to maximum speed and check that no oil or air is leaking from serviced parts.
- Move the controls and check that the machine is operating properly.

### Disposing of wastes

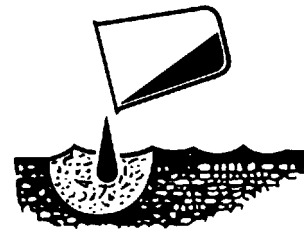

E3A640

- Funnel spent fluids from the machine into containers. Disposing of fluids improperly destroys the environment.
- Follow the prescribed regulations when disposing of oil, fuel, engine coolant, refrigerant, solvents, filters, batteries or other harmful substances.

**CAUTIONS DURING DISASSEMBLY AND ASSEMBLY**

1. Clean the machine before disassembly operation.
2. Before disassembly, check the machine conditions and record them.
  - Model, Machine Serial Number, Hourmeter
  - Reason for Repairs, Repair History
  - Dirtiness of Filters
  - Fuel and Oil Conditions
  - Damage to each parts, etc.
3. To make reassembly operations easy, make matching marks at the necessary points.
4. Clean all disassembled parts and new parts, then arrange them in the proper sequence.
5. Be sure to replace all seals and cotter pins, etc., with new parts.
6. Keep parts which should not come in contact with oil and water separate from parts with oil on them.
  - Electrical Parts, Rubber, V-Belts, etc.
7. When installing bearings, bushings and oil seals, as a rule, use a press. When a hammer, etc., is used, it leaves bruises.
8. Wipe all joining surfaces clean so that there is no dirt or dust adhering to them.
9. Wrap seal tape from the front end, Wrapping it tight and leaving 1 or 2 threads bare, Overlap the tape by about 10 mm.

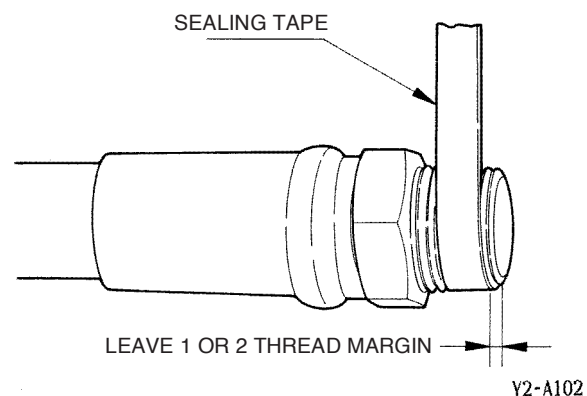

10. When fitting the snap rings, the bigger, rounder side of their circumferences should face the mating surfaces.

## GENERAL

---

### CAUTIONS DURING REMOVAL AND INSTALLATION OF THE HYDRAULIC UNITS

1. Make sure that the hydraulic oil's temperature has dropped.
2. To prevent a loss of flow of the hydraulic oil, the residual pressure in the piping and the internal pressure in the hydraulic oil tank should be bled out.
3. Be sure to install caps or plugs on all openings in the hydraulic unit to prevent dirt from getting into the unit through the openings.

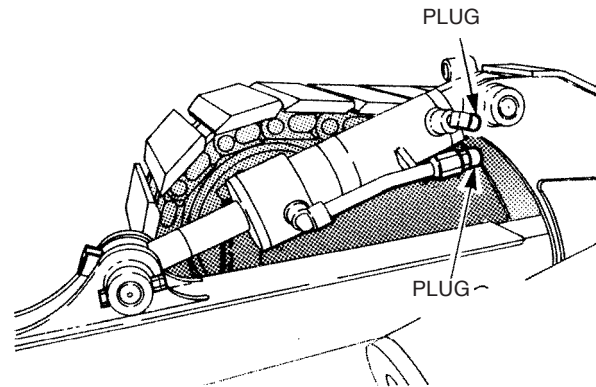

V2-A103

4. It is easy to mistake hydraulic oil adhering to the hydraulic unit for an oil leak, so wipe the unit off thoroughly.
5. Be sure that no damage is done to the plating on the rod in the hydraulic cylinder.
6. As a rule, removal and installation of the hydraulic cylinder should be done with the rod fully retracted.
7. Be sure to bleed the air after replacing the hydraulic oil or removing any of the hydraulic devices.  
☞ “III. Machine Configuration, Hydraulic System”
8. After installation of the hydraulic unit, be sure to pressurize the hydraulic oil tank. If this operation is forgotten, it could cause cavitation of the hydraulic pump. Also, it could have a drastic effect on the life of the hydraulic pump.  
☞ “III. Machine Configuration, Hydraulic System”

**CAUTIONS DURING REMOVAL AND INSTALLATION OF PIPING**

1. When hydraulic hoses are installed, tighten them once to the prescribed torque, then loosen them slightly and retighten them to the prescribed torque.
  - Tighten the fittings after the installation surfaces fit snugly together.
  - Pieces wrapped with seal tape are excluded.
2. Use 2 spanners, each on an opposite side, to remove and tighten fittings so that the hoses or steel pipes are not twisted.

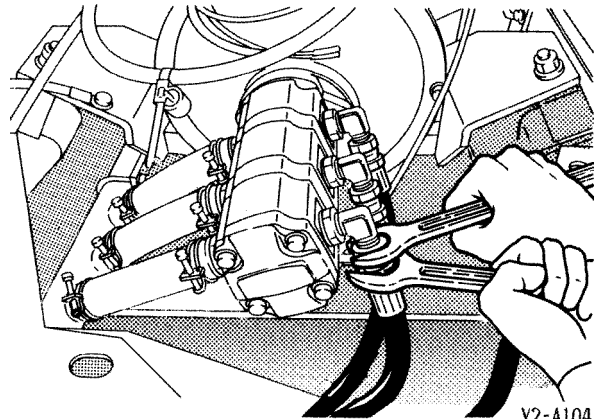

V2-A104

3. After installation of hydraulic hoses or steel pipes, apply the maximum working pressure 5 or 6 times and confirm that there is no leakage.

## GENERAL

---

### HANDLING OF SEALS

1. Clean the grooves for O-rings and if there is any ridge, etc., remove it.

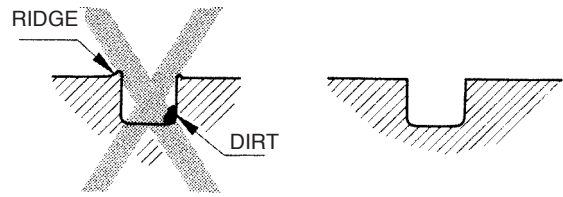

Y2-A105

2. Be careful not to twist O-rings. If an O-ring is twisted, remove the twist with the fingertips.
3. During insertion, be careful not to damage the seal.
4. Handling of Floating Seals
  - Wipe all oil off the O-ring and housing of the floating seal.
  - When assembling, apply a thin coating of gear oil to the contact surface of the housing.
  - After assembly, turn the seal 2 or 3 times to get it to fit snugly.
5. Apply grease to the lip of the oil seal.
  - This is to prevent wear when it is first started up after assembly.

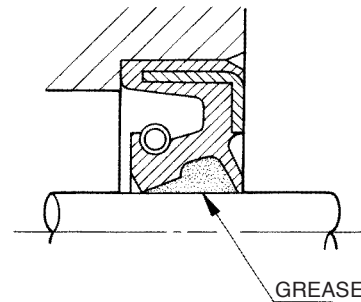

Y2-A106



**TIGHTENING TORQUES**

**Hydraulic Hoses**

Hose Fitting Size	Torque			
	Union Nut (G)		Taper Thread (R)	
	N·m	ft-lb	N·m	ft-lb
1/8	9.8 <sup>+4.9</sup> <sub>0</sub>	7.3 <sup>+3.5</sup> <sub>0</sub>	11.8 ±1.2	8.7 ±0.8
1/4	24.5 <sup>+4.9</sup> <sub>0</sub>	18.1 <sup>+3.5</sup> <sub>0</sub>	29.4 ±2.9	21.7 ±2.1
3/8	49 <sup>+4.9</sup> <sub>0</sub>	36.2 <sup>+3.5</sup> <sub>0</sub>	53.9 ±5.4	39.8 ±3.9
1/2	58.8 <sup>+4.9</sup> <sub>0</sub>	43.4 <sup>+3.5</sup> <sub>0</sub>	88.3 ±8.8	65.1 ±6.4
3/4	117.7 <sup>+4.9</sup> <sub>0</sub>	86.8 <sup>+3.5</sup> <sub>0</sub>	147.1 ±14.7	108.5 ±10.7
1	137.3 <sup>+4.9</sup> <sub>0</sub>	101.3 <sup>+3.5</sup> <sub>0</sub>	196.1 ±19.6	144.7 ±14.3

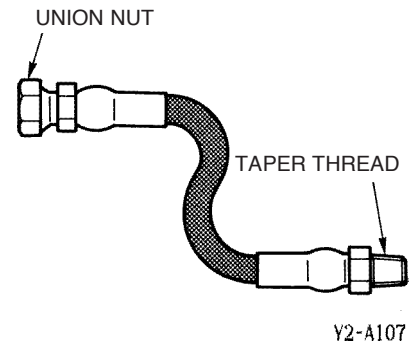

**Bite Type Pipe Fitting for Steel Pipe**

Pipe Outer Diameter (mm)	Torque	
	N·m	ft-lb
8	34.3 ±4.9	25.3 ±3.5
10	41.7 ±2.5	30.7 ±1.7
12	58.8 ±4.9	43.4 ±3.5
15	88.3 ±4.9	65.1 ±3.5
16	93.2 ±4.9	68.7 ±3.5
18	132.4 ±4.9	97.6 ±3.5
22	205.9 ±9.8	151.8 ±7.2
27.2	245.2 ±9.8	181.0 ±7.2
28	313.8 ±19.6	231.4 ±14.3
32	313.8 ±19.6	231.4 ±14.3
35	411.9 ±19.6	303.7 ±14.3

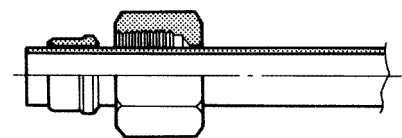

# GENERAL

## Joins for Piping

Nominal Thread Diameter (R)	Torque			
	Steel		Cast Steel	
	N·m	ft-lb	N·m	ft-lb
1/8	11.8 ±1.2	8.7 ±0.8	10.8 ±1.1	8.0 ±0.7
1/4	29.4 ±2.9	21.7 ±2.1	24.5 ±2.5	18.1 ±1.7
3/8	53.9 ±5.4	39.8 ±3.9	49 ±4.9	36.2 ±3.5
1/2	88.3 ±8.8	65.1 ±6.4	73.5 ±7.4	54.3 ±5.3
3/4	147.1 ±14.7	108.5 ±10.7	127.5 ±12.7	94.1 ±9.3
1	196.1 ±19.2	144.7 ±14.3	171.6 ±17.2	126.6 ±12.5

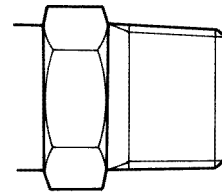

Y2-A109

## Joins for Piping (O-ring Seal Type)

Nominal Thread Diameter (G)	Torque	
	N·m	ft-lb
1/8	19.6 ±2.0	14.5 ±1.4
1/4	34.3 ±4.9	25.3 ±3.5
3/8	53.9 ±4.9	39.8 ±3.5
1/2	63.7 ±4.9	47.0 ±3.5
3/4	93.2 ±4.9	68.7 ±3.5
1	107.9 ±9.8	79.5 ±7.2
1-1/4	117.7 ±9.8	86.8 ±7.2
1-1/2	137.3 ±9.8	101.2 ±7.2

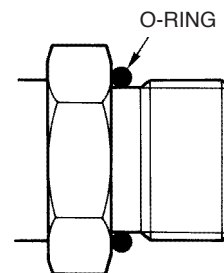

Y2-A110

Nominal Thread Diameter (UNF)	Torque	
	N·m	ft-lb
7/16-20	16.7 ±2.0	12.3 ±1.4
1/2-20	22.6 ±2.0	16.6 ±1.4
9/16-18	31.4 ±2.9	23.1 ±2.1
3/4-16	59.8 ±4.9	44.1 ±3.5
1-1/16-12	102.0 ±5.9	75.2 ±4.4
1-5/16-12	135.3 ±7.8	99.8 ±5.8
1-5/8-12	181.4 ±9.8	133.8 ±7.2

**Bolts and Nuts (for ISO Strength Category 10.9)**

Thread	Size × Pitch	Torque					
		General Tightening Points			Special Tightening Points		
		N·m	kgf·m	ft-lb	N·m	kgf·m	ft-lb
Coarse	M 6 × 1.0	9.8 ±0.5	1.0 ±0.05	7.2 ±0.4	11.8 ±0.6	1.2 ±0.06	8.7 ±0.4
	M 8 × 1.25	22.6 ±1.1	2.3 ±0.11	16.6 ±0.8	26.5 ±1.3	2.7 ±0.13	19.5 ±0.9
	M10 × 1.5	47.1 ±2.4	4.8 ±0.24	34.7 ±1.7	54.9 ±2.7	5.6 ±0.28	40.5 ±2.0
	M12 × 1.75	83.4 ±4.1	8.5 ±0.42	61.5 ±3.0	97.1 ±4.8	9.9 ±0.49	71.6 ±3.5
	M14 × 2.0	134.4 ±6.7	13.7 ±0.68	99.1 ±4.9	155.9 ±7.7	15.9 ±0.79	115.0 ±5.7
	M16 × 2.0	207.9 ±10.4	21.2 ±1.06	153.3 ±7.7	241.2 ±12.1	24.6 ±1.23	177.9 ±8.9
	M20 × 2.5	410.9 ±20.5	41.9 ±2.09	303.1 ±15.1	475.6 ±23.7	48.5 ±2.42	350.8 ±17.5
Fine	M 8 × 1.0	24.5 ±1.2	2.5 ±0.12	18.1 ±0.9	28.4 ±1.4	2.9 ±0.14	21.0 ±1.0
	M10 × 1.25	50.0 ±2.5	5.1 ±0.25	36.9 ±1.8	58.8 ±2.9	6.0 ±0.30	43.4 ±2.2
	M12 × 1.5	87.3 ±4.3	8.9 ±0.44	64.4 ±3.2	102.0 ±5.1	10.4 ±0.52	75.2 ±3.8
	M14 × 1.5	135.3 ±6.8	13.8 ±0.69	99.9 ±5.0	157.9 ±7.8	16.1 ±0.80	116.5 ±5.8
	M16 × 1.5	220.6 ±11.0	22.5 ±1.12	162.7 ±8.1	256.0 ±12.7	26.1 ±1.30	188.8 ±9.4
	M20 × 1.5	452.1 ±22.6	46.1 ±2.30	333.4 ±16.6	524.7 ±26.1	53.5 ±2.66	387.0 ±19.2

- General Tightening Points (Non-lubricated)
  - All securing points other than the special tightening points.
- Special Tightening Points (Grease with molybdenum disulfide applied.)
  - Points where particularly necessary due to function.  
Special tightening positions and associated instructions are given in the text.
- Points where thread-locking compound is used (Three Bond #1324 is applied.)  
Thread-locking compound positions and associated instructions are given in the text.
- If tightening torque values are provided in this manual, then tightening should be done according to those values.  
(This indicates that the tightening torque differs from the values given in this table.)
- In order to tighten bolts and nuts evenly, they should be tightened alternately top, bottom, left, right.

**BUY NOW**

**Then Instant Download  
the Complete Manual  
Thank you very much!**