



TEREX®

TC 29 SERVICE - MANUAL

List of Contents

- 1 General**
- 2 Technical Data**
- 3 Diesel Engine**
- 4 Hydraulic System**
- 5 Setting Instructions**
- 6 Functional Description**
- 7 Electrical System**
- 8 Maintenance**
- 9 Operation**
- 10 Options**
- 11 Repair Instructions**
- 12 BDE/Special tooling**

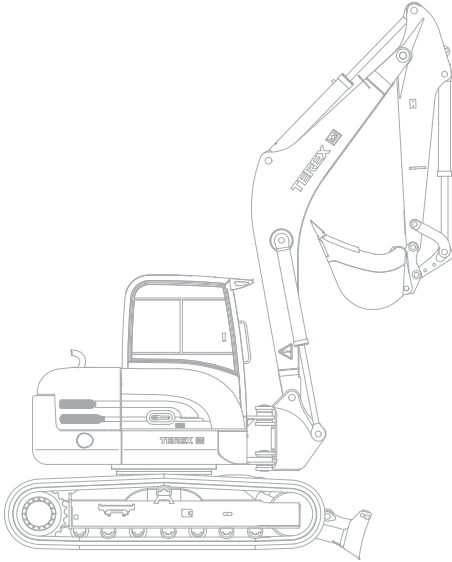

Deletion of trained keys

The deletion of trained keys is necessary, if a trained key were lost. During the erasing process all trained keys are deleted. After the deletion all existing keys can again be trained the delete procedure effected via putting the master key into the starter lock and operation of the position '1 \ ' (terminal 15) for min. 20s. Thereafter are all registered keys are deleted. All existing keys are able to be trained again. The code of the master key is not deleted with the erasing process.

Maschinentyp	Füllmenge	Füllmedium	Prüf-Füllanschluß-type	Schaltdruck Magnetkupplung ein	Schaltdruck Magnetkupplung aus	
Machine Type	Filling Quantities	Cooling agent	Test Port Type	Pressure Solenoid Coupling on	Pressure Solenoid Coupling off	
TL65 (SKL824)	800g	R134a	R134a genormt	2bar	25 bar	
	1.764 lb	R134a	R134a standard	29 PSI	363 PSI	
TL70s (SKS634)	800g	R134a	R134a genormt	2bar	25 bar	
	1.764 lb	R134a	R134a standard	29 PSI	363 PSI	
TL80 (SKL834)	800g	R134a	R134a genormt	2bar	25 bar	
	1.764 lb	R134a	R134a standard	29 PSI	363 PSI	
TL100 (SKL844)	800g	R134a	R134a genormt	2bar	25 bar	
	1.764 lb	R134a	R134a standard	29 PSI	363 PSI	
TL120 (SKL854)	800g	R134a	R134a genormt	2bar	25 bar	
	1.764 lb	R134a	R134a standard	29 PSI	363 PSI	
TL160 (SKL160)	900g	R134a	R134a genormt	2bar	25 bar	
	1.985 lb	R134a	R134a standard	29 PSI	363 PSI	
SKL873-200	1100g	R134a	R134a genormt	2bar	25 bar	
	2.426 lb	R134a	R134a standard	29 PSI	363 PSI	
TL210	900g	R134a	R134a genormt	2bar	25 bar	
	1.985 lb	R134a	R134a standard	29 PSI	363 PSI	
TL260 (SKL260)	900g	R134a	R134a genormt	2bar	25 bar	
	1.985 lb	R134a	R134a standard	29 PSI	363 PSI	
TL420	1200g	R134a	R134a genormt	2bar	25 bar	
	2.646 lb	R134a	R134a standard	29 PSI	363 PSI	
TL450	1200g	R134a	R134a genormt	2bar	25 bar	
	2.646 lb	R134a	R134a standard	29 PSI	363 PSI	
TW70 (HML23)	1200g	R134a	R134a genormt	2 bar	27 bar	
	2.646 lb	R134a	R134a standard	29 PSI	392 PSI	
TW85 (HML32)	1200g	R134a	R134a genormt	2 bar	27 bar	
	2.646 lb	R134a	R134a standard	29 PSI	392 PSI	
TW110 (HML42)	1200g	R134a	R134a genormt	2 bar	27 bar	
	2.646 lb	R134a	R134a standard	29 PSI	392 PSI	
TC60 (HR20)	1100g	R134a	R134a genormt	2 bar	27 bar	
	2.426 lb	R134a	R134a standard	29 PSI	392 PSI	
TC75 (HR32)	1200g	R134a	R134a genormt	2 bar	27 bar	
	2.646 lb	R134a	R134a standard	29 PSI	392 PSI	
TC125 (HR42)	1200g	R134a	R134a genormt	2 bar	27 bar	
	2.646 lb	R134a	R134a standard	29 PSI	392 PSI	
TC48 (HR18)	1250g	R134a	R134a genormt			
	2.756 lb	R134a	R134a standard			
TC50	1250g	R134a	R134a genormt			
	2.756 lb	R134a	R134a standard			

Thank you very much for reading.

This is part of the demo page.

GET MORE:

**Diesel Engine, Hydraulic
System, Setting
Instructions, Functional
Description, Electrical
System And more.....**

Click Here BUY NOW

**Then Instant Download
the Complete Manual.**